



# c-pro 3 micro CHIL

Programmable controllers for single-and two-circuits chillers-heat pumps



<b>IMPORTANT NOTICE</b>	
	<p>This Instruction Manual should be read carefully before installation and before use, and all warnings relating to installation and electrical connections should be observed; the Manual should then be kept for future reference.</p>
	<p><b>All devices must be disposed of in accordance with local regulations governing the disposal of electrical and electronic devices.</b></p>

## SOMMARIO

<b>1</b>	<b>INTRODUCTION .....</b>	<b>6</b>
1.1	Introduction .....	6
<b>2</b>	<b>APPLICATIONS .....</b>	<b>7</b>
2.1	Basic application scheme of an Air-To-Water twin circuit chiller .....	8
<b>3</b>	<b>HARDWARE SOLUTIONS .....</b>	<b>9</b>
<b>4</b>	<b>DIMENSIONS .....</b>	<b>10</b>
4.1	Dimensions of controller and user interface .....	10
4.1.1	Dimensionscontrol modulec-pro 3microCHILand c-pro 3 EXP micro+ .....	10
<b>5</b>	<b>USER INTERFACE .....</b>	<b>12</b>
5.1	Displays and Keyboards.....	12
<b>6</b>	<b>LIST OF PAGES.....</b>	<b>13</b>
6.1	Password.....	14
6.2	Unit OFF main page .....	14
6.3	Unit ON main page .....	15
6.4	Menu StAt (Only for display LED) .....	16
6.4.1	Meaning of LED (only for display LED) .....	17
6.5	General Menu .....	18
6.6	User Menu .....	18
6.7	Maintenance Menu.....	18
6.8	Installer Menu .....	19
6.9	Constructor Menu .....	20
6.10	RTC Menu .....	20
6.11	Alarms Menu .....	20
<b>7</b>	<b>PARAMETERS LIST .....</b>	<b>21</b>
7.1	List of Configuration Parameters.....	22
7.2	AI Configuration (HA01-HA18 parameters).....	41
7.3	DI Configuration(HB01-HB18 parameters).....	42
7.4	AO Configuration (HC01-HC18 parameters) .....	42
7.5	DO Configuration (HD01-HD18 parameters).....	43
<b>8</b>	<b>REGULATIONS.....</b>	<b>44</b>
8.1	Machine Status .....	44
8.2	Unit Type .....	45
8.2.1	Water-To-Water Chiller with EVDRIVE03 .....	45
8.2.2	Water-To-Water Chiller .....	46
8.2.3	Water-To-Water Chiller+Heat Pump with EVDRIVE03.....	47
8.2.4	Water-To-Water Chiller+Heat Pump .....	48
8.2.5	Air-To-Water Chiller with EVDRIVE03 .....	49
8.2.6	Air-To-Water Chiller .....	50
8.2.7	Air-To-Water Chiller+Heat Pump with EVDRIVE03.....	51
8.2.8	Air-To-Water Chiller+Heat Pump .....	52

<b>8.3 Configuration of Circuits</b> .....	<b>53</b>
<b>8.4 Operating Mode Control</b> .....	<b>54</b>
<b>8.5 Setting the RTC</b> .....	<b>55</b>
<b>8.6 Compressor Control</b> .....	<b>56</b>
8.6.1 Lateral-band (LB) control.....	56
8.6.2 Zero energy band (ZEB) control .....	57
8.6.3 Auto adaptive control .....	58
<b>8.7 Compressor Management</b> .....	<b>58</b>
8.7.1 Compressor status .....	58
8.7.2 Rotation of compressors .....	58
8.7.3 Pump-down switch-OFF procedure .....	59
8.7.4 Relative-threshold pump-down .....	59
8.7.5 Protection timings.....	60
8.7.6 Thermal protection inputs .....	61
<b>8.8 Condenser control</b> .....	<b>61</b>
8.8.1 Modulating fan control .....	61
8.8.2 Single stage fan control .....	64
8.8.3 Condenser valve control.....	64
8.8.4 Single condenser.....	64
<b>8.9 Fan Management</b> .....	<b>65</b>
8.9.1 Fan status .....	65
8.9.2 Fan timings .....	65
8.9.3 Thermal Protection Inputs .....	65
<b>8.10 Circulating Pump Management</b> .....	<b>66</b>
8.10.1 Pump Status.....	67
8.10.2 Flow Meter Management .....	67
<b>8.11 Circulating Source Pump Management</b> .....	<b>68</b>
<b>8.12 Defrosting Management</b> .....	<b>68</b>
8.12.1 Defrosting cycle compensation .....	69
<b>8.13 Anti-freeze management / Chilling-support heating coils</b> .....	<b>69</b>
<b>8.14 Single evaporation</b> .....	<b>69</b>
<b>8.15 Free-Cooling Management</b> .....	<b>70</b>
8.15.1 Enabling of Free-Cooling .....	70
8.15.2 Regulation of Free-Cooling .....	70
8.15.3 Free-Cooling control valve .....	72
<b>8.16 Temperature Alarm Control</b> .....	<b>73</b>
8.16.1 Low and high temperature alarm management.....	73
8.16.2 Management of primary exchanger efficiency alarm .....	73
<b>8.17 Pressure Alarm Control</b> .....	<b>73</b>
8.17.1 Management of high-pressure pressure-switch alarm .....	73
8.17.2 Management of high-pressure transducer alarm.....	73
8.17.3 Management of low-pressure pressure-switch alarm (chiller mode) .....	73
8.17.4 Management of low-pressure transducer alarm (heat pump mode).....	74
8.17.5 Low start-up pressure alarm.....	74
<b>8.18 Time schedule</b> .....	<b>75</b>
<b>8.19 Miscellaneous Management</b> .....	<b>76</b>
8.19.1 Set point variation by schedule timer.....	76
8.19.2 Dynamic set point .....	76

8.19.3	Forced shutdown.....	77
8.19.4	High-pressure reduction at high temperatures (chiller).....	77
8.19.5	Low-pressure partialization at low temperatures (heat pump) .....	78
8.19.6	Operating limit management (heat pump) .....	79
8.19.7	Function of Cooling/Heating upon request.....	79
8.19.8	Set-point change from digital input.....	79
<b>8.20</b>	<b>Management of EVDRIVE03 integrated into the system .....</b>	<b>80</b>
8.20.1	Enabling of EEV operation .....	80
8.20.2	PID parameters set .....	80
8.20.3	Modulation of the SH set .....	80
8.20.4	CAN Configuration.....	80
<b>8.21</b>	<b>Manual operation .....</b>	<b>81</b>
8.21.1	Compressors .....	81
8.21.2	Fans .....	81
8.21.3	Pumps .....	81
<b>8.22</b>	<b>Resetting of default parameters.....</b>	<b>82</b>
<b>8.23</b>	<b>Parametering key.....</b>	<b>82</b>
<b>9</b>	<b>WIRING DIAGRAM .....</b>	<b>83</b>
9.1	Connection layout <i>c-pro 3 micro CHIL</i> .....	83
9.2	Connection layout <i>c-pro 3 EXP micro+</i> .....	85
9.3	Connection layout <i>EVDRIVE03</i> .....	87
9.4	Connection layout <i>Vgraph</i> .....	89
9.5	<i>c-pro 3 micro CHIL</i> .....	90
<b>10</b>	<b>9.5.1 Table of connection <i>c-pro 3 micro CHIL</i> .....</b>	<b>91</b>
<b>11</b>	<b>DIAGNOSTICS .....</b>	<b>92</b>
11.1	Manual and Automatic Alarms.....	92
11.2	Manual-reset alarms .....	92
11.3	Automatic-reset alarms.....	92
11.4	Alarm Table.....	93
11.5	Alarms History .....	96
<b>12</b>	<b>LIST OF Modbus® VARIABLES .....</b>	<b>97</b>

# 1 INTRODUCTION

## 1.1 Introduction

The programmable controllers of the **c-pro 3 micro CHIL** series are devices studied for the management of single and two-circuits chillers-heat pumps up to three scroll compressors for each circuit.

They make use of the programmable controllers, of the I/O expansions and of the remote user interfaces belonging to the **c-pro 3** series and are programmed with an application software implemented with the development environment UNI-PRO 3.

They are available in built-in and in blind version; the blind versions must be used with a remote user interface.

The controllers can manage air to water and water to water chillers-heat pumps; through the CAN communication port the controllers can also communicate with an external driver (EVDRIVE03) for bipolar stepper electronic expansion valves.

They can be powered in alternating current (12 VAC). Through the programming port it is possible to make the upload and the download of the configuration parameters (using a common USB peripheral); through the RS-485 one, with MODBUS communication protocol, it is possible to connect the devices to the set-up software system Parameters Manager or to the plants monitoring and supervision one via Internet Cloud Evolution instead. Through the CAN communication port it is finally possible to connect the devices to the I/O expansion, to the remote user interface and to the external electronic expansion valves driver.

The application program is capable of managing air-to-water and water-to-water units, mono or twin circuit.

The following are only some of the numerous control functions available:

<b>Available functions</b>
Manage up to 3 scroll compressors for each circuit
Manage compressors with cooling – heating mode
Manage fans with phase-cut module
Manage electronic valve EVDRIVE03 for each circuit
Free-Cooling management
Defrost and anti-frost
Double set-point that can be enabled from external contact
Dynamic set point compensation
Pump-down management
Build in schedule with 2 daily programs
Control of condensing pressure / linear or stepped evaporation
One, two or no circulating pumps
One, two or no source circulating pumps

## 2 APPLICATIONS

The controllers are able to manage the following unit types :

<b>Air-To-Water single circuit</b>
Air-To-Water single circuit Chiller
Air-To-Water single circuit Chiller with EEV driver
Air-To-Water single circuit Chiller + HeatPump
Air-To-Water single circuit Chiller + HeatPump with EEV driver

<b>Water-To-Water single circuit</b>
Water-To-Water single circuit Chiller
Water-To-Water single circuit Chiller with EEV driver
Water-To-Water single circuit Chiller + HeatPump
Water-To-Water single circuit Chiller + HeatPump with EEV driver

<b>Air-To-Water twin circuit</b>
Air-To-Water twin circuit Chiller
Air-To-Water twin circuit Chiller with EEV driver
Air-To-Water twin circuit Chiller + HeatPump
Air-To-Water twin circuit Chiller + HeatPump with EEV driver

<b>Water-To-Water twin circuit</b>
Water-To-Water twin circuit Chiller
Water-To-Water twin circuit Chiller with EEV driver
Water-To-Water twin circuit Chiller + HeatPump
Water-To-Water twin circuit Chiller + HeatPump with EEV driver

## 2.1 Basic application scheme of an Air-To-Water twin circuit chiller

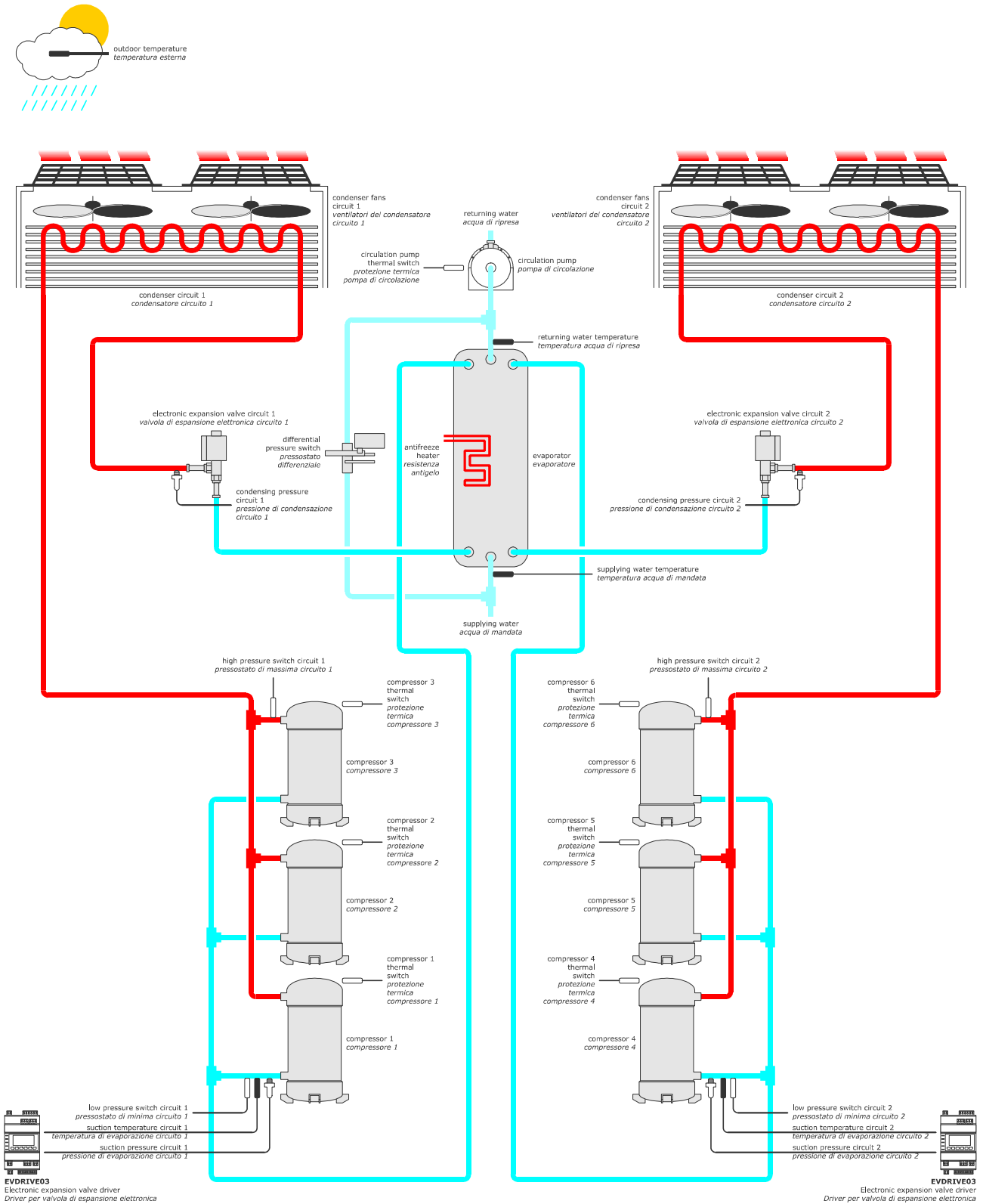



### 3 HARDWARE SOLUTIONS

Hardware	Article	Code
Controller (built-in version)	<b>c-pro 3</b> <i>micro CHIL</i>	EPU2LXP1CH
Controiller (blind version)	<b>c-pro 3</b> <i>micro CHIL</i>	EPU2BXP1CH
I/O expansion	<b>c-pro 3</b> <i>EXP micro+</i>	EPU2EXP
EEV driver (built-in version)	EVDRIIVE03	EPD4DF3
EEV driver (blind version)	EVDRIIVE03	EPD4BC3

To manage the second circuit it is necessary to use an I/O expansion **c-pro***EXP micro+* and to manage the electronic expansion valve it is necessary to use a driver EVDRIIVE03.

For management of the blind versions it is also necessary to use a remote user interface LCD**Vgraph**, an interface equipped with 6 keys/edit pages, states and enabling the same.

A description of the keys used by the application.

## 4 DIMENSIONS

### 4.1 Dimensions of controller and user interface

Below we will show the dimensions, assembly and electric connections of the **c-pro 3 micro CHIL**.

#### 4.1.1 Dimensions control module c-pro 3 micro CHIL and c-pro 3 EXP micro+

4 DIN modules, installation DIN rail mounting; the dimensions are in mm (in).

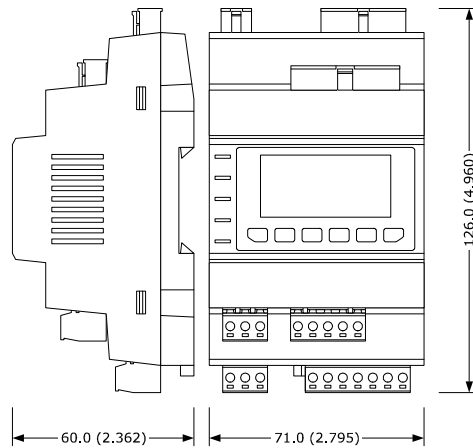

#### 4.1.2 Dimensions remote user interface Vgraph.

Installation by panel; the dimensions are in mm (in).

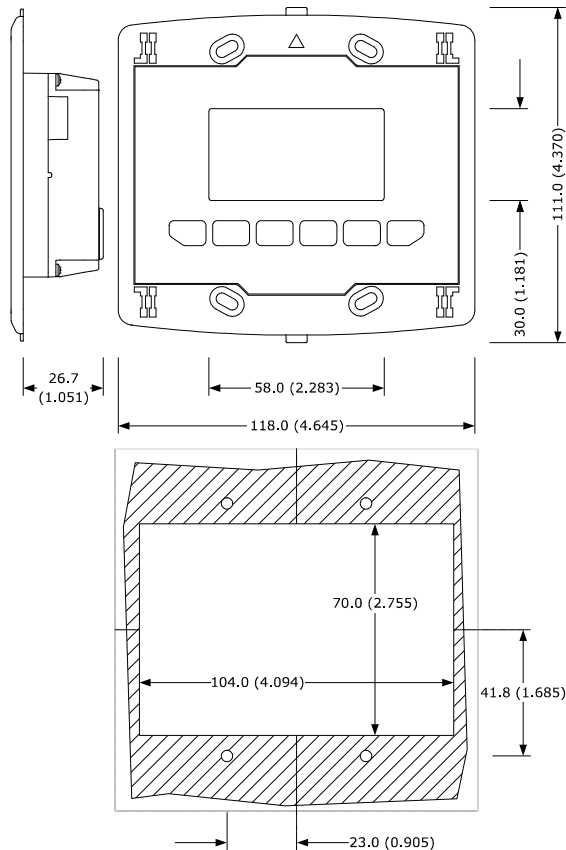

### 4.1.3 Dimensions module EVDRIVE03

4 DIN modules, installation DIN rail mounting; the dimensions are in mm(in).

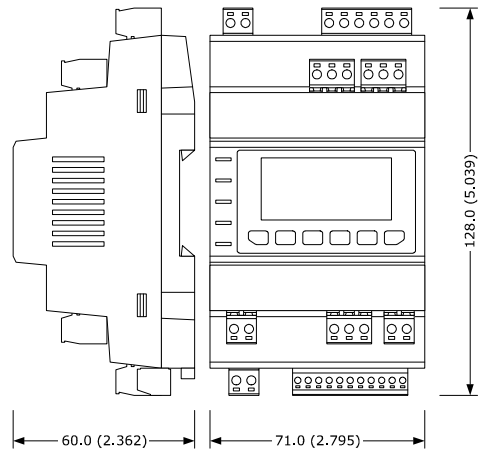

## 5 USER INTERFACE







For the application, two types of interface are provided:

- Built-in LED-display interface
- Remote LCD-display interface **Vgraph**.

Both interfaces feature 6 keys for navigation/page editing, and differ in their display mode of certain associated statuses, i.e. via icons. For both versions, a description is provided of the keys used by the application; indeed, according to the interface in use, it is possible to manage a different number of keys.

### 5.1 Displays and Keyboards

The keyboard features 6 page navigation and value editing keys, which have the following functions:

Symbol	Functions
 	In editing, it modifies parameters; otherwise, it moves the cursor.
	During editing, it confirms the value; otherwise, it sends any commands associated to the text where the cursor is positioned. If pressed down and held for about 2 seconds, the ENTER key enables access to the main menu. If held down during display of an alarm page, this key enables resetting of the alarm. If alarm pages are being displayed, every key press scrolls all active alarms.
	During editing, it cancels the value; otherwise, it requests any default page that might be associated with the current page. If pressed down and held for about 2 seconds, the ESC key enables ON/OFF switching of the machine. If pressed in the main page, this key will display the list of all active alarms.
 	It displays the pages of the same level in succession.

## 6 LIST OF PAGES

This chapter describes the main pages and menus featured in the application. As already described earlier, the general menu is subdivided into four submenu levels: user, maintenance operator, installation operator, and configuration.

The menu structure is the following:

Menu	Function of the menu
<b>General Menu</b>	RTC Menu
	Alarm Menu
	User Menu (Level 1)
<b>Maintenance Menu (Level 2)</b>	Operation
	Manual
	Calibration
	Input/output
<b>Installer Menu (Level 3)</b>	Compressors
	Regulation
	Fans
	Defrost
	Pumps
	Anti-Freeze
	Free-Cooling
	Device safeties
	Modbus
	Various parameters
<b>Constructor Menu (Level 4)</b>	Configuration
	Hardware configuration
	EVDRIIVE03 (Circuit 1, Circuit 2)

## 6.1 Password

Each menu is assigned a level, which affects the accessibility of the various menus.

Each level is assigned a password, which enables access to the various functions featured in that menu; once the correct password has been entered, protected functions become accessible. Entering of the correct password has two consequences:

- Unlocking of the related level;
- Unlocking of its sublevels.

All level passwords can be modified from the same level or from higher levels. For example, from the constructor level it will be possible to modify all passwords of underlying levels, by using the appropriate page.

The range of values that can be set for a password is -999 / 9999.

After 4 minutes have elapsed without any key being pressed, the password expires and it is necessary to reset it.

## 6.2 Unit OFF main page

The main display page varies according to the machine status, i.e. on or off: If the machine is switched OFF, Unit OFF is displayed, with indication of the cause for the shutdown (keyboard, DI, Supervisor, Scheduler, Alarm, Change-Over).

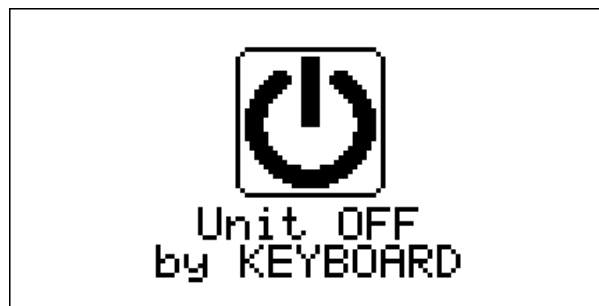

Pressing the ESC key from this page brings the user to the Alarm page.

### 6.3 Unit ON main page

When the unit is turned on, the following main screen will be displayed:

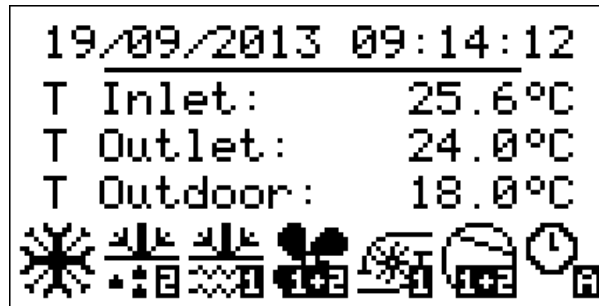

At the bottom of the page, icons will be displayed that indicate various statuses of circuit operation.

The table below contains graphic representations of the individual icons, the relative operational status and what is being verified. From left to right:

Icon	Operational status	Event displayed
	Summer/Winter/Alarm Icon	In case there is an active alarm, the alarm icon will be displayed alternatively with the icon of the operational mode (summer/winter)
	Defrost Icon	Indicates that circuit defrost is in progress (1,2). If flashing, it is in dripping phase
	Antifreeze Icon	Indicates that the antifreeze resistance mechanism is active (heat sink or source) in the circuit indicated (1,2 1+2)
	Fan Icon	Indicates that the circuit fans (1,2, 1+2) are active
	Pump Icon	Indicates which circulation pump (1,2) is active
	Compressor Icon	Indicates that at least one circuit compressor (1,2, 1+2) is active
	Time Slot Icon	Indicates which time slot is active (A,B)

From this page, by pressing the RIGHT or LEFT keys, it is possible to display other information regarding pumps, fans, compressors, defrost, circuit status, RTC and all configured sensors. In case of fault status of the sensors, the value field of the corresponding sensor displays "----", or else "----" if the sensor is disabled.

Pressing the ESC key from this page brings the user to the Alarm page.

## 6.4 Menu StAt (Only for display LED)

If the *StAt* voice is chosen from the general menu, several main statuses of the system are displayed (can be navigated with the Left/Right buttons) on the reference page:

Exemplatable of system statuses displayed on Page 1

Reference page	Status displayed	System status
Page 1	<b>Unit</b>	Indicates the status in which the machine operates ( <b>OFF, ChIL, pdC, dFr, dRIp, F-C</b> )
Page 1	<b>ModE</b>	Indicates the operational mode of the machine ( <b>ChIL, pdC</b> )
Page 1	<b>tdF1</b>	Accumulation of wait time for defrost circuit 1
Page 1	<b>dFr1</b>	Duration of circuit defrost 1
Page 1	<b>tdF2</b>	Accumulation of wait time for defrost circuit 2
Page 1	<b>dFr2</b>	Duration of defrostcircuit 2
Page 1	<b>SEtC</b>	Summer mode current set point
Page 1	<b>SEtH</b>	Winter mode current set point
Page 1	<b>rEGP</b>	Main regulation probe
Page 1	<b>PREq</b>	Power required [%]
Page 1	<b>PSup</b>	Power supplied[%]

Example table of system statuses displayed on Page 2

Reference page	Status displayed	System status
Page 2	<b>CMP1, CMP2 .. CMP6</b>	Status of compressors ( <b>dIS, OFF, tOn, On, tOFF, ALAr, MAnU</b> )
Page 2	<b>FAn1, FAn 2</b>	Status of fans ( <b>dIS, OFF, tOn, On, tOFF, ALAr, MAnU</b> )
Page 2	<b>InF1, InF2</b>	Speed of condenser fans [%]
Page 2	<b>PMP1, PMP2</b>	Status of pumps ( <b>dIS, OFF, On, ALAr, MAnU</b> )
Page 2	<b>PMS1, PMS2</b>	Status of heat source pumps ( <b>dIS, OFF, On, ALAr, MAnU</b> )
Page 2	<b>F-C</b>	Status of free-cooling activation
Page 2	<b>vF-C</b>	Free-cooling valve
Page 2	<b>FF-C</b>	Free-cooling regulation
Page 2	<b>vpC1</b>	Status of C1splitter valve for free-cooling
Page 2	<b>vpC2</b>	Status of C2 splitter valve for free-cooling

Sample table of system statuses displayed on Page 3

Reference page	Status displayed	System status
Page 3	<b>tExt</b>	External temperature probe
Page 3	<b>tAux</b>	Remote temperature probe
Page 3	<b>tiFc</b>	Machine input temperature probe (Free-Cooling)
Page 3	<b>tin</b>	Heat sink exchanger input temperature probe
Page 3	<b>toC1/2</b>	Heat sink exchanger output temperature probe (circuit 1,2)
Page 3	<b>toS1/2</b>	Heat source exchanger input temperature probe (circuit 1,2)
Page 3	<b>tCo1/2</b>	Coil temperature probe (circuit 1,2)
Page 3	<b>GAS1/2</b>	Exhaust gas compressor temperature probe (circuit 1,2)
Page 3	<b>tSu1/2</b>	Intake compressor temperature probe (circuit 1,2)
Page 3	<b>PCO1/2</b>	Condensing pressure probe (circuit 1,2)
Page 3	<b>PEV1/2</b>	Evaporation pressure probe (circuit 1,2)
Page 3	<b>Pun1/2</b>	Single pressure probe (circuit 1,2)



Pressing ENTER on the label causes the value of the relative status to be displayed; pressing ESC brings you back to the general menu screen. This menu is not protected by a password.

#### 6.4.1 Meaning of LED (only for display LED)

The LED display offers several icons that display particular statuses of the unit:

- **OnOff.** If on, it means that the unit has no power; if off, it means that the unit is on; if on with slow flashing light, it means that the unit is not being powered by the Scheduler; if on with fast flashing light, it means that the unit is not being powered by the Supervisor or Digital Input.
- **Snow.** If on, summer/winter function (see parameter PH53); if on and flashing, the free-cooling function is active.
- **Sun.** If on, summer/winter function (see parameter PH53).
- **Alarm.** If on, the function indicates the presence of alarms; if on and flashing, it indicates the presence of new alarms not displayed yet; if off, there are no alarms.
- **Defrost.** If on, it means that defrosting is active in one of the 2 circuits; if on and flashing, it means that draining is active in one of the 2 circuits
- **Maintain.** If on, it means that at least one device is functioning manually; if on and flashing, it means that a "device operating hours" alarm is active.
- **Compressor 1.** If on, it means that at least one compressor of circuit 1 is active; if off, it means that no circuit compressors are active; if on and flashing slowly, it means that a circuit compressor is in the alarm state; if on and flashing quickly, it means that a circuit compressor is in manual mode.
- **Compressor 2.** If on, it means that at least one compressor of circuit 2 is active; if off, it means that no circuit compressors are active; if on and flashing slowly, it means that a circuit compressor is in the alarm state; if on and flashing quickly, it means that a circuit compressor is in manual mode.
- **Pump.** If on, it means that a heat sink pump is active; if off, it means that no pumps are active; if on and flashing slowly, it means that a pump is in the alarm state; if on and flashing quickly, it means that a pump is in manual mode.
- **Fan.** If on, it means that one fan is active; if off, it means that no fans are active; if on and flashing slowly, it means that a fan is in the alarm state; if on and flashing quickly, it means that a fan is in manual mode.
- **Heaters:** If on, it means that the strength of the antifreeze mechanism (heat sink or source) is active; if off, it means that no antifreeze mechanisms are active; if on and flashing slowly, it means that an antifreeze mechanism is in the alarm state.
- **EVCO.** Icon linked to the functioning of parameter PH52.

## 6.5 General Menu

The general menu has no level and represents the access point for all the other system menus.

Display LCD	Display LED
<b>USER</b>	<b>USEr</b>
<b>MAINTENANCE</b>	<b>MAin</b>
<b>INSTALLER</b>	<b>InSt</b>
<b>CONSTRUCTOR</b>	<b>CoSt</b>
<b>RTC</b>	<b>rTC</b>
<b>ALARMS</b>	<b>ALrm</b>
<b>HISTORY</b>	<b>HiSt</b>
<i>Not present</i>	<b>StAt</b>

It is possible to view this menu from any point within the user interface by pressing ENTER for approximately 2 seconds. From this menu you can choose the menu you wish to view by pressing the UP and DOWN keys followed by pressing the ENTER key for confirmation.

In the upper right hand corner of the image appears a "v" which represents the focus.

This indication specifies to the user that additional information is contained therein and can be viewed by pressing the DOWN key (or UP key depending on the direction of the focus) scrolling to view the content that is not viewable in the current page.

## 6.6 User Menu

The User menu is a Level 1 menu, i.e. it requires entering of the User level (or higher) password, in order to be able to display/modify the parameters contained in this branch.

## 6.7 Maintenance Menu

The Maintenance menu is a Level 2 menu, i.e. it requires entering of the Maintenance operator level (or higher) password, in order to be able to display/modify the parameters contained in this branch.

Display LCD	Display LED
<b>OPERATION</b>	<b>OPEr</b>
<b>MANUAL</b>	<b>MAnU</b>
<b>CALIBRATION</b>	<b>CAL</b>
<b>IN/OUT</b>	<b>I-O</b>
<b>PASSWORD</b>	<b>PSd2</b>

In this menu, it is possible to view the status of the various devices, inputs and outputs utilized by the application.

In the OPERATION menu, it is possible to view/enable the features relating to the operation of compressors, fans and pumps. Some examples of these are the hours of operation, the threshold of maximum allowable hours.

In the MANUAL menu, it is possible to set to manual/automatic operation compressors, pumps and fans, whose outputs can be forced, in order to test their functionality.

In the CALIBRATION menu, it is possible to set the corrections to be applied to analogue inputs, to compensate the offsets due to cabling and sensor positioning.

In the I/O STATUS menu, it is possible to view directly the card's physical inputs and outputs

## 6.8 Installer Menu

The installation menu is a Level 3 menu, i.e. it requires entering of the installation level (or higher) password, in order to be able to display/modify the parameters contained in this branch.

Display LCD	Display LED
<b>COMPRESSORS</b>	<b>CoMP</b>
<b>REGULATION</b>	<b>rEG</b>
<b>FANS</b>	<b>FANS</b>
<b>DEFROST</b>	<b>dEFr</b>
<b>PUMPS</b>	<b>PuMP</b>
<b>ANTI-FREEZE</b>	<b>A-F</b>
<b>FREE-COOLING</b>	<b>F-C</b>
<b>SAFETIES</b>	<b>SAFE</b>
<b>MODBUS</b>	<b>MdbS</b>
<b>VARIOUS</b>	<b>Par</b>
<b>SAVE/RESTORE</b>	<b>MAp</b>
<b>PASSWORD</b>	<b>PSd3</b>

The installation operator menu contains all the parameters connected with the configuration of all functionalities (alarms, settings, logic, rotation type, etc.) of the machine.

In the REGULATION menu, it is possible to set the parameters connected with lateral-band and zero energy band temperature control of compressors.

In the COMPRESSORS menu, it is possible to set the parameters connected with the management of devices:

- rotation
- timings
- maximum number of start-ups.

In the FANS menu, it is possible to set the parameters connected with the control of condensation pressure, via the fans.

In the DEFROST menu, it is possible to set the parameters connected with the activation and duration of heat pump defrosting.

In the PUMP menu, it is possible to set the parameters connected with operation and protection of pumps.

In the ANTI-FREEZE menu, it is possible to set the parameters connected with the thermal control of resistors and control of the anti-frost alarm.

In the FREE-COOLING menu, it is possible to set the parameters connected with free-cooling function and damper.

The SAFETIES DEVICES menu contains all parameters connected with alarms and management of safety devices which protect the refrigerating circuit:

- activations
- reporting delays
- type of resetting.

In the MODBUS menu it is possible to set the parameters connected with modbus.

The VARIOUS PARAMETERS menu contains other general parameters connected with the management of Modbus communications, transducer full-scale values and other configurable activations.

From the SAVE/RESTORE menu it is possible to restore the default values of all parameters of the application and save or download from the programming key or internal controller memory.

## 6.9 Constructor Menu

The Configuration menu is a Level 4 menu, i.e. it requires entering of the Configuration level password, in order to be able to display/modify the parameters contained in this branch. Furthermore, this level is only accessible with the machine in OFF mode.

Display LCD	Display LED
<b>CONFIGURATION</b>	<b>COnF</b>
<b>HARDWARE</b>	<b>H-AI</b>
	<b>H-dI</b>
	<b>H-AO</b>
	<b>H-dO</b>
<b>EVCM C1-C2</b>	<b>vCM1</b>
	<b>vCM2</b>
<b>PASSWORD</b>	<b>PSd</b>

This menu contains all the machine's configuration parameters, which determine its operation mode and which functionalities are to be enabled or disabled.

The CONFIGURATION menu contains the parameters machine configuration.

The HARDWARE menu allows to configure the I/O of the unit.

The EVCM menu allows to configure the main parameters of EVDRIVE03 for each Circuit.

## 6.10 RTC Menu

This menu contains the functionality of the systems Real Time Clock, as setting the real time clock and setting daily scheduler (*PTxx* parameters).

## 6.11 Alarms Menu

This menu allows viewing and acknowledging of alarms.

Display LCD	Display LED
<b>Show Alarms</b>	<b>ALrm</b>
<b>Show History</b>	<b>HiSt</b>

The SHOW ALARMS menu shows the active alarms. Each time the DOWN key is pressed, the next active alarm is shown. If no alarms are present, the message "NO ALARMS" is displayed.

The alarm can be acknowledged by pressing the ENTER key for 2 seconds, when the alarm condition is not active anymore.

The ALARM HISTORY page will show the latest alarm. To view the preceding alarm press ENTER key. This can be repeated until the first alarm is displayed. The history is viewed in a circular manner.

By pressing the ESC key or after 60 seconds of no key activity, the main page will be displayed.

## 7 PARAMETERS LIST

The parameters managed by the application are listed below. Each parameter is accompanied by a brief description, the range of its admissible values, units of measure, the assigned default value and the menu containing the parameter. Menus are structured on the basis of the following logic:

Menu code	Reference menu	Status
<b>OR</b>	RTC menu	
<b>UT</b>	User menu	
<b>MA</b>	Maintenance menu	
<b>MA-F</b>	Maintenance menu	Operation
<b>MA-M</b>	Maintenance menu	Manual
<b>MA-C</b>	Maintenance menu	Calibration
<b>MA-IO</b>	Maintenance menu	Input/Output
<b>IS</b>	Installation menu	
<b>IS-C</b>	Installation menu	Compressors
<b>IS-R</b>	Installation menu	Regulation
<b>IS-F</b>	Installation menu	Fans
<b>IS-D</b>	Installation menu	Defrost
<b>IS-P</b>	Installation menu	Pumps
<b>IS-AF</b>	Installation menu	Anti-freeze
<b>IS-FC</b>	Installation menu	Free-Cooling
<b>IS-S</b>	Installation menu	Safeties
<b>IS-M</b>	Installation menu	Modbus
<b>IS-V</b>	Installation menu	Various
<b>CO</b>	Configuration menu	
<b>CO-W</b>	Configuration menu	Configuration
<b>CO-HW</b>	Configuration menu	Hardware
<b>CO-V</b>	Configuration menu	<b>EVDRIVE03</b> circuit 1 and <b>EVDRIVE03</b> circuit 2

## 7.1 List of Configuration Parameters

Code	Parameter Description	Default	Min.	Max.	M.U.	Menu	Notes
	<b>RTC MEN - This menu is accessible ifPG03=1</b>						
PT01	Working day 1 enable zone 1	0	0	1		OR	
PT02	Working day 1 zone 1 start time	0	00:00:00	23:59:59		OR	
PT03	Working day 1 zone 1 stop time	0	00:00:00	23:59:59		OR	
PT04	Working day 1 zone 1 cooling offset	0	-20.0	20.0	°C	OR	
PT05	Working day 1 zone 1 heating offset	0	-20.0	20.0	°C	OR	
PT06	Working day 1 enable zone 2	0	0	1		OR	
PT07	Working day 1 zone 2 start time	0	00:00:00	23:59:59		OR	
PT08	Working day 1 zone 2 stop time	0	00:00:00	23:59:59		OR	
PT09	Working day 1 zone 2 cooling offset	0	-20.0	20.0	°C	OR	
PT10	Working day 1 zone 2 heating offset	0	-20.0	20.0	°C	OR	
PT11	Working day 2 enable zone 1	0	0	1		OR	
PT12	Working day 2 zone 1 start time	0	00:00:00	23:59:59		OR	
PT13	Working day 2 zone 1 stop time	0	00:00:00	23:59:59		OR	
PT14	Working day 2 zone 1 cooling offset	0	-20.0	20.0	°C	OR	
PT15	Working day 2 zone 1 heating offset	0	-20.0	20.0	°C	OR	
PT16	Working day 2 enable zone 2	0	0	1		OR	
PT17	Working day 2 zone 2 start time	0	00:00:00	23:59:59		OR	
PT18	Working day 2 zone 2 stop time	0	00:00:00	23:59:59		OR	
PT19	Working day 2 zone 2 cooling offset	0	-20.0	20.0	°C	OR	
PT20	Working day 2 zone 2 heating offset	0	-20.0	20.0	°C	OR	
PT21	Monday schedule	1	0	2		OR	0= none working day 1= working day1 2= working day2
PT22	Tuesday schedule	1	0	2		OR	0= none working day 1= working day1 2= working day2
PT23	Wednesday schedule	1	0	2		OR	0= none working day 1= working day1 2= working day2
PT24	Thursday schedule	1	0	2		OR	0= none working day 1= working

							day1 2= working day2
PT25	Friday schedule	1	0	2		OR	0= none working day 1= working day1 2= working day2
PT26	Saturday schedule	0	0	2		OR	0= none working day 1= working day1 2= working day2
PT27	Sunday schedule	0	0	2		OR	0= none working day 1= working day1 2= working day2
<b>Level 1</b>	<b>USER MENU</b>						
ModE	It sets the operating mode: 0: Cool, (Chiller/summer) 1: Heat (Heat pump/winter)	0	0	1		UT	Modifiable only if the units is a chiller + heat pump: (PG00=2,4)
SPC1	It sets the value of the summer set point (chiller)	8.5	PC21	PC22	°C	UT	
SPH1	It sets the value of the winter set point (heat pump).	44.0	PC23	PC24	°C	UT	
PUC1	Offset for the summer set point by digital input	2.0	-20.0	20.0	°C	UT	
PUH1	Offset for the winter set point by digital input	-2.0	-20.0	20.0	°C	UT	
PSd1	It modifies the password at User level.	0	-999	9999		UT	
<b>Level 2</b>	<b>MAINTENANCE MENU</b>						
	<b>OPERATION</b>						
PM00	It sets the maximum number of operating hours of compressors. When this limit is exceeded, the connected alarm is triggered.	2000	0	9999	Hrs. x10	MA-F	
PM01 PM02 PM03 PM04 PM05 PM06	It shows the number of operating hours of compressors. One parameter for each compressor.	0	0	9999	Hrs. x10	MA-F	
PM30	It sets the maximum number of operating hours of pumps. When this	2000	0	9999	Hrs. x10	MA-F	

	limit is exceeded, the connected alarm is triggered.						
PM31	It shows the number of operating hours of the first pump.	0	0	9999	Hrs. x10	MA-F	
PM32	It shows the number of operating hours of the second pump.	0	0	9999	Hrs. x10	MA-F	
PM33	It shows the number of operating hours of the first source pump.	0	0	9999	Hrs. x10	MA-F	
PM34	It shows the number of operating hours of the second source pump.	0	0	9999	Hrs. x10	MA-F	
PM40	It sets the maximum number of operating hours of fans. When this limit is exceeded, the connected alarm is triggered.	2000	0	9999	Hrs. x10	MA-F	
PM41	It shows the number of operating hours of the first fan or of the inverter in Circuit # 1.	0	0	9999	Hrs. x10	MA-F	
PM42	It shows the number of operating hours of the second fan or of the inverter in Circuit # 2.	0	0	9999	Hrs. x10	MA-F	
PM43	It shows the number of operating hours of the free-coolind dedicated fan	0	0	9999	Hrs. x10	MA-F	
PM90	Last maintenance date				-	MA-F	
<b>MANUAL</b>							
PM11 PM12 PM13 PM14 PM15 PM16	It enables the manual/automatic operation of the compressor. 0: Auto – normal operation 1: Manu – manual operation One for each compressor.	0	0	1		MA-M	
PM21 PM22 PM23 PM24 PM25 PM26	During manual operation, it forces the start-up/shutdown of the compressor. 0: switches the compressor OFF 1: switches the compressor ON One for each compressor.	0	0	1		MA-M	
PM35	It enables the manual/automatic operation of the pump # 1. 0: Auto – normal operation 1: Manu – manual operation	0	0	1		MA-M	
PM36	It enables the manual/automatic operation of the pump # 2. 0: Auto – normal operation 1: Manu – manual operation	0	0	1		MA-M	
PM37	During manual operation, it forces the start-up/shutdown of pump #1	0	0	1		MA-M	
PM38	During manual operation, it forces the start-up/shutdown of pump #2	0	0	1		MA-M	
PM45	It enables the manual/automatic operation of the source pump # 1. 0: Auto – normal operation 1: Manu – manual operation	0	0	1		MA-M	Only for Water-Water unit
PM46	It enables the manual/automatic	0	0	1		MA-M	Only for



	operation of the source pump # 2. 0: Auto – normal operation 1: Manu – manual operation						Water-Water unit
PM47	During manual operation, it forces the start-up/shutdown of source pump #1	0	0	1		MA-M	Only for Water-Water unit
PM48	During manual operation, it forces the start-up/shutdown of source pump #2	0	0	1		MA-M	Only for Water-Water unit
PM51	It enables the manual/automatic operation of the condensing fan in Circuit # 1. 0: Auto – normal operation 1: Manu – manual operation	0	0	1		MA-M	
PM52	It enables the manual/automatic operation of the condensing fan in Circuit # 2. 0: Auto – normal operation 1: Manu – manual operation	0	0	1		MA-M	
PM61	During manual operation, it forces the value of the condensing fan in Circuit #1.	0	0	100	%	MA-M	With PF01=1 (Modulating Control)
PM62	During manual operation, it forces the value of the condensing fan in Circuit #2.	0	0	100	%	MA-M	With PF01=1 (Modulating Control)
PM63	During manual operation, it forces the value of the condensing fan in Circuit #1.	0	0	1		MA-M	With PF01=0 (Single stage Control)
PM64	During manual operation, it forces the value of the condensing fan in Circuit #2.	0	0	1		MA-M	With PF01=0 (Single stage Control)
PM65	It enables the manual/automatic operation of the dedicated free-cooling fan: 0: Auto – normal operation 1: Manu – manual operation	0	0	1		MA-M	Only for Chillers Air-Water unit When PG13>0
PM66	During manual operation, it forces the value of the dedicated free-cooling fan	0	0	100	%	MA-M	Only for Chillers Air-Water unit When PG13=1
PM67	During manual operation, it forces the value of the dedicated free-cooling fan	0	0	1		MA-M	Only for Chillers Air-Water unit When PG13=2
<b>CALIBRATION</b>							
PM71	Calibration of external temperature sensor	0.0	-10.0	10.0	°C	MA-C	
PM72	Calibration of free-cooling input temperature sensor	0.0	-10.0	10.0	°C	MA-C	
PM73	Calibration of entering temperature	0.0	-10.0	10.0	°C	MA-C	

	sensor						
PM74	Calibration of leaving temperature sensor circuit 1	0.0	-10.0	10.0	°C	MA-C	
PM75	Calibration of leaving temperature sensor circuit 2	0.0	-10.0	10.0	°C	MA-C	
PM76	Calibration of source leaving temperature sensor circuit 1	0.0	-10.0	10.0	°C	MA-C	
PM77	Calibration of source leaving temperature sensor circuit 2	0.0	-10.0	10.0	°C	MA-C	
PM78	Calibration of coil temperature sensor circuit 1	0.0	-10.0	10.0	°C	MA-C	
PM79	Calibration of coil temperature sensor circuit 2	0.0	-10.0	10.0	°C	MA-C	
PM80	Calibration of discharge compressors temperature sensor circuit 1	0.0	-10.0	10.0	°C	MA-C	
PM81	Calibration of discharge compressors temperature sensor circuit 2	0.0	-10.0	10.0	°C	MA-C	
PM82	Calibration of remote aux.temperature sensor	0.0	-10.0	10.0	°C	MA-C	
PM83	Calibration of condensing pressure sensor circuit 1	0.0	-20.0	20.0	Bar	MA-C	
PM84	Calibration of condensing pressure sensor circuit 2	0.0	-20.0	20.0	Bar	MA-C	
PM85	Calibration of evaporating pressure sensor circuit 1	0.0	-20.0	20.0	Bar	MA-C	
PM86	Calibration of evaporating pressure sensor circuit 2	0.0	-20.0	20.0	Bar	MA-C	
PM87	Calibration of unique pressure sensor circuit 1	0.0	-20.0	20.0	Bar	MA-C	
PM88	Calibration of unique pressure sensor circuit 2	0.0	-20.0	20.0	Bar	MA-C	
PSd2	It modifies the password at Maintenance Operator level.	0	-999	9999		MA-F	
<b>Level 3</b>	<b>INSTALLATION MENU</b>						
	<b>COMPRESSORS</b>						
PC01	Rotation type used for compressor management: 0: FIFO 1: LIFO 2: FIFO + hours 3: LIFO + hours	0	0	3		IS-C	
PC02	Enabling mode of compressors in the two circuits: 0: Circuit balancing 1: Circuit saturation	0	0	1		IS-C	Only on twin circuits
PC04	Min. time for which the compressor must remain ON, even if a shutdown has been requested.	20	0	999	Sec.	IS-C	
PC05	Min. time for which the compressor must remain OFF, even if a start-up has been requested.	120	0	999	Sec.	IS-C	
PC06	Min. time which must elapse between two start-ups of the same	360	0	999	Sec.	IS-C	

	compressor.						
PC07	Min. time which must elapse between start-ups of two different compressors.	360	0	999	Sec.	IS-C	
PC08	Min. time which must elapse between shutdowns of two different compressors.	180	0	999	Sec.	IS-C	
PC09	Max. number of start-ups for every hour (only for adaptive control).	8	4	12		IS-C	
PC10	Number of compressors per circuit which will be forced in case of a regulating-sensor alarm.	1	0	PG03		IS-C	
<b>REGULATION</b>							
PC11	It sets the control type for compressor management: 0: Lateral band 1: Zero energy band	1	0	1		IS-R	
PC12	Proportional band for lateral-band control of compressors	2.5	1.0	20.0	°C	IS-R	
PC14	Zone value for neutral-zone control of compressors	3.0	PC15	PC16	°C	IS-R	
PC15	Min. value of compressor zero energy band	1.0	0.1	10.0	°C	IS-R	
PC16	Max. value of compressor zero energy band	5.0	0.1	10.0	°C	IS-R	
PC17	Enabling/release time for subsequent compressor step outside the zero energy band	20	0	999	Sec.	IS-R	
PC18	Enabling for auto-adaptive control of the compressors' zero energy band	No (0)	No (0)	Yes (1)		IS-R	
PC21	Min. value of summer set point (chiller)	5.0	-15.0	SPC1	°C	IS-R	
PC22	Max. value of summer set point (chiller)	20.0	SPC1	23.0	°C	IS-R	
PC23	Min. value of winter set point (heat pump)	30.0	23.0	SPH1	°C	IS-R	
PC24	Max. value of winter set point (heat pump)	44.0	SPH1	70.0	°C	IS-R	
PC31	Power limiting for summer	50	0	100	%	IS-R	
PC32	Power limiting for winter	50	0	100	%	IS-R	
PC35	Enabling of forced shutdown of compressors	No (0)	No (0)	Yes (1)		IS-R	
PC36	Summer forced shutdown set point	3.5	-30.0	23.0	°C	IS-R	
PC37	Winter forced shutdown set point	52.0	26.0	75.0	°C	IS-R	
PC41	Enabling of pump-down 0 : No 1 : Yes, with timing 2 : Yes, with relative threshold	1	0	2		IS-R	
PC42	Compressor shutdown time in pump-down	5	0	240	Sec.	IS-R	
PC43	Relative threshold for pump-down disabling	1.5	0.0	5.0	Bar	IS-R	
PC45	Enabling of high-temperature pressure-switch control (chiller)	No (0)	No (0)	Yes (1)		IS-R	

PC46	Pressure set point for high-temperature pressure-switch control	27.0	0.0	45.0	Bar	IS-R	
PC47	Pressure differential for high-temperature pressure-switch control	2.0	0.0	5.0	Bar	IS-R	
PC48	External high temperature threshold for pressure-switch control	12.0	-30.0	23.0	°C	IS-R	
PC49	Min. time for maintaining pressure-switch partialization	10	0	99	Min.	IS-R	
PC50	Enabling of low-temperature pressure-switch control (heat pump)	No (0)	No (0)	Yes (1)		IS-R	
PC51	Pressure setpoint for low-temperature pressure-switch control	3.2	0.0	10.0	Bar	IS-R	
PC52	Pressure differential for low-temperature pressure-switch control	2.0	0.0	10.0	Bar	IS-R	
PC53	External low temperature threshold for pressure-switch control	-5.0	-10.0	5.0	°C	IS-R	
PC54	Outlet water high-temperature threshold for pressure-switch control	48.0	30.0	70.0	°C	IS-R	
PC55	Delay for partialization from low pressure alarm	900	0	999	Sec.	IS-R	
PC61	Summer commutation set point	20.0	PC62	70.0	°C	IS-R	
PC62	Winter commutation set point	10.0	0.0	PC61	°C	IS-R	
PC64	Max. dynamic offset compared to summer set point (chiller)	-10.0	-20.0	20.0	°C	IS-R	
PC65	Compensation start temperature for dynamic summer set point	30.0	-15.0	PC66	°C	IS-R	
PC66	Compensation stop temperature for dynamic summer set point	60.0	PC65	70.0	°C	IS-R	
PC67	Max. dynamic offset compared to winter set point (heat pump)	10.0	-20.0	20.0	°C	IS-R	
PC68	Compensation start temperature for dynamic winter set point	0.0	-15.0	PC69	°C	IS-R	
PC69	Compensation stop temperature for dynamic winter set point	30.0	PC68	70.0	°C	IS-R	
PC70	Function limit management: 0 = Heat pump only 1 = Auxiliary output 2 = Auxiliary output and heat pump	0	0	2		IS-R	
PC71	Function limit set point	-7.0	-30.0	30.0	°C	IS-R	
PC72	Function limit differential	4.0	0.1	10.0	°C	IS-R	
PC80	Enabling of control upon request	No (0)	No (0)	Si (1)		IS-R	
PC81	Summer setpoint control upon request	15.0	-15.0	70.0	°C	IS-R	
PC82	Winter setpoint control upon request	45.0	-15.0	70.0	°C	IS-R	
PC83	Summer differential control upon request	4.0	0.1	10.0	°C	IS-R	
PC84	Winter differential control upon request	4.0	0.1	10.0	°C	IS-R	
PC85	Delayed control upon request	5	0	999	Sec	IS-R	
<b>FANS</b>							
PF01	Condenser control type	0	0	1		IS-F	0=Modulating control 1=Single stage control
PF02	It gives the choice to enable fan	Yes (1)	No (0)	Yes (1)		IS-F	

	control only if at least one compressor is ON.						
PF03	It sets whether or not fans must switch OFF during defrosting cycles.	No (0)	No (0)	Yes (1)		IS-F	
PF07	Min. time which must elapse between the start-ups of two different fans.	10	0	999	Sec.	IS-F	
PF08	Min. time which must elapse between the shutdowns of two different fans.	20	0	999	Sec.	IS-F	
PF09	Forcing of fans in case of condensing sensor alarm	No (0)	No (0)	Yes (1)		IS-F	With PF01=0 (Single stage Control)
PF10	Forcing of fans in case of condensing sensor alarm	0.0	0.0	100.0	%	IS-F	With PF01=1 (Modulating Control)
PF11	Condensing control set point for summer operation (chiller)	20.0	5.0	45.0	Bar	IS-F	
PF12	Linear control band for condensation in summer operation (chiller)	12.0	0.1	15.0	Bar	IS-F	
PF13	Enabling of forcing to maximum	Yes (1)	No (0)	Yes (1)		IS-F	
PF14	Max. forcing enabling set point in summer operation (chiller)	26.0	15.0	45.0	Bar	IS-F	
PF15	Disabling differential for max. forcing in summer operation (chiller)	2.0	0.1	5.0	Bar	IS-F	
PF16	Integral time for control of valves (cooling)	0	0	999	Sec	IS-F	If PF16=0 Integral action not present
PF21	Condensing control set point in winter operation (heat pump)	9.0	0.5	15.0	Bar	IS-F	
PF22	Linear control band for condensation in winter operation (heat pump)	2.0	0.1	15.0	Bar	IS-F	
PF24	Max. forcing activation set point in winter operation (heat pump, inverter)	3.2	0.5	20.0	Bar	IS-F	
PF25	Max. forcing de-activation differential in winter operation (heat pump, inverter)	0.5	0.1	5.0	Bar	IS-F	
PF26	Integral time for control of valves (heat pump)	0	0	999	Sec	IS-F	If PF26=0 Integral action not present
PF27	Min. value for condenser forcing (inverter)	0.0	0.0	100.0	%	IS-F	
PF28	Speed-up time at fan start-up (inverter)	4	0	999	Sec.	IS-F	
PF31	Lower limit for condensing linear control (inverter)	30.0	0	PF32	%	IS-F	
PF32	Upper limit for condensing linear control (inverter)	100.0	PF31	100.0	%	IS-F	
PF33	Enabling of control under the minimum condensing limit (inverter)	Yes (1)	No (0)	Yes (1)		IS-F	
PF34	Switch-off differential under the minimum condensing limit (inverter)	2.0	0.0	5.0	Bar	IS-F	
PF36	Enabling of preventilation 0: No 1: Winter only	0	0	2		IS-F	

	2: Always						
PF38	Preventilation speed	50.0	0.0	100.0	%	IS-F	With PF01=1 (Modulating Control)
PF39	Preventilation time	10	0	999	Sec	IS-F	
PF41	Value x1 of fan linearization table	25.0	0.0	PF42	%	IS-F	
PF42	Value x2 of fan linearization table	50.0	PF41	PF43	%	IS-F	
PF43	Value x3 of fan linearization table	75.0	PF42	100.0	%	IS-F	
PF45	Value y1 of fan linearization table	25.0	0.0	PF46	%	IS-F	
PF46	Value y2 of fan linearization table	50.0	PF45	PF47	%	IS-F	
PF47	Value y3 of fan linearization table	75.0	PF46	100.0	%	IS-F	
	<b>DEFROST</b>						Only for Air-Water unit
Pd01	Pressure set point at defrosting start	6.0	0.0	Pd02	Bar	IS-D	
Pd02	Pressure set point at defrosting stop	12.0	Pd01	45.0	Bar	IS-D	
Pd03	Waiting interval at defrosting start	1200	60	Pd23	Sec.	IS-D	
Pd05	Max. duration of defrosting	300	10	600	Sec.	IS-D	
Pd06	Duration of dripping	120	0	600	Sec.	IS-D	
Pd07	Min. defrost waiting interval after compressor re-start	60	0	600	Sec.	IS-D	
Pd20	Enabling of defrosting cycle compensation	No (0)	No (0)	Yes (1)		IS-D	
Pd21	Outdoor air temperature set point for defrosting compensation start	5.0	Pd22	70.0		IS-D	
Pd22	Outdoor air temperature set point for defrosting compensation stop	0.0	-30.0	Pd21		IS-D	
Pd23	Max. waiting interval at defrosting stop	3600	Pd03	9600		IS-D	
	<b>PUMPS</b>						
PP01	Pump operation: 0 = Continuous operation 1 = Operation at thermostat's request 2 = Cyclical operation	0	0	2		IS-P	
PP02	ON time in cyclical operation	120	1	999	Sec.	IS-P	
PP03	OFF time in cyclical operation	120	1	999	Sec.	IS-P	
PP04	Min. interval which must elapse between pump start-up and first compressor	60	1	999	Sec.	IS-P	
PP05	Min. interval which must elapse between circuit shutdown and pump	60	1	999	Sec.	IS-P	
PP07	Shutdown of pump during defrosting	No (1)	No (0)	Yes (1)		IS-P	
PP08	Difference in operating hours between the two pumps, requiring their being swapped.	4	1	240	Hours	IS-P	
PP09	Pump operating time at low water flow (flow alarm)	15	0	999	Sec.	IS-P	
PP10	Pump operating time at low temperature of outflow water (anti-frost alarm)	15	0	999	Sec.	IS-P	
PP21	Source Pump operation: 0= Continuous operation 1=Operation at thermostat's request 2 = Cyclical operation	0	0	2		IS-P	Only for Water-Water unit
	<b>ANTI-FREEZE</b>						

Pr01	Enabling of anti-frost heating elements	Yes (1)	No (0)	Yes (1)		IS-AF	
Pr02	Anti-frost heating element set point	5.0	Pr05	10.0	°C	IS-AF	
Pr03	Anti-frost heating element differential	2.0	0.1	10.0	°C	IS-AF	
Pr04	Forcing of anti-frost heating elements with sensor error	No (0)	No (0)	Yes (1)		IS-AF	
Pr05	Anti-frost alarm threshold	3.0	-30.0	Pr02	°C	IS-AF	
Pr06	Anti-frost alarm differential	2.0	0.1	10.0	°C	IS-AF	
Pr11	Enabling of anti-frost heating elements on source exchanger	Yes (1)	No (0)	Yes (1)		IS-AF	Only for Water-Water unit
Pr12	Anti-frost heating element set point on source exchanger	5.0	Pr15	10.0	°C	IS-AF	
Pr13	Anti-frost heating element differential on source exchanger	2.0	0.1	10.0	°C	IS-AF	
Pr14	Forcing of anti-frost heating elements with sensor error on source exchanger	No (0)	No (0)	Yes (1)		IS-AF	
Pr15	Anti-frost alarm threshold on source exchanger	3.0	-30.0	Pr12	°C	IS-AF	
Pr16	Anti-frost alarm differential on source exchanger	2.0	0.1	10.0	°C	IS-AF	
	<b>FREE-COOLING</b>						Only for Chillers Air-Water unit
PS01	Free-cooling enabling	No (0)	No (0)	Yes (1)		IS-FC	
PS02	free-cooling variable frequency drive	3.0	0.1	20.0	°C	IS-FC	
PS03	Minimum fan speed	0.0	0.0	PS04	%	IS-FC	
PS04	Maximum fan speed	100.0	PS03	100.0	%	IS-FC	
PS05	Free-cooling enabling when the compressors are on	Yes (1)	No (0)	Yes (1)		IS-FC	
PS06	Free-cooling activation differential setPoint	3.0	0.5	10.0	°C	IS-FC	
PS07	Free-cooling activation differential	2.0	0.5	5.0	°C	IS-FC	
PS08	ON/OFF hysteresis valve	0.5	0.1	5.0	°C	IS-FC	
PS09	3-way valve opening maximum differential	2.0	0.1	PS02	°C	IS-FC	
PS10	Free-cooling minimum enabling time	30	0	240	Sec	IS-FC	
PS15	Enabling of condensersplitter valve in free-cooling	Yes (1)	No (0)	Yes (1)		IS-FC	
PS16	Splitter valve SetPoint	11.0	0.5	20.0	Bar	IS-FC	
PS17	Splitter valve differential	3.0	0.1	10.0	Bar	IS-FC	
	<b>DEVICE SAFETIES</b>						
PA01	Flow alarm delay from machine start-up	10	1	999	Sec.	IS-S	
PA02	Flow alarm by-pass time during normal operation	1	1	999	Sec.	IS-S	
PA03	Number of triggered flow alarms with auto-reset before the alarm becomes manual	3	0	9		IS-S	
PA04	Delay interval for notification of sensor error	10	0	240	Sec.	IS-S	
PA05	High-temperature alarm threshold during summer operation (chiller)	30.0	10.0	40.0	°C	IS-S	
PA06	Low-temperature alarm threshold	15.0	10.0	40.0	°C	IS-S	

	during winter operation (heat pump)						
PA07	Triggering delay for temperature alarm	30	1	999	Sec.	IS-S	
PA08	Consequent time for a temperature alarm: 0 = Notification only 1 = Machine stop	0	0	1	Sec.	IS-S	
PA09	Reset differential for temperature alarm	0.5	0.1	10.0	°C	IS-S	
PA10	Temperature alarm inhibition interval from system start-up	15	0	999	Sec.	IS-S	
PA11	Low-pressure alarm threshold during winter operation (heat pump)	3.0	0.1	9.9	Bar	IS-S	
PA12	Low-pressure alarm reset differential during winter operation (heat pump)	1.0	0.1	4.0	Bar	IS-S	
PA13	Low-pressure alarm by-pass interval from start-up of first compressor	120	0	999	Sec.	IS-S	
PA14	Number of triggered low-pressure alarms with auto-reset before the alarm becomes manual	3	0	5		IS-S	
PA16	Enabling of low-pressure control at start-up and at low temperatures	Yes (1)	No (0)	Yes (1)		IS-S	
PA17	Low-pressure alarm threshold at start-up and at low temperatures	1.0	0.1	9.9	Bar	IS-S	
PA18	Low-pressure alarm reset differential at start-up and at low temperatures	0.5	0.1	4.0	Bar	IS-S	
PA19	Control duration at triggering of low-pressure alarm at low temperatures	120	10	PA13	Sec.	IS-S	
PA20	Min. duration of alarm delay for triggering of low-pressure alarm at compressor start-up	240	0	999	Sec.	IS-S	
PA21	High-pressure alarm threshold	28.0	0.0	45.0	Bar	IS-S	
PA22	High-pressure alarm reset differential	5.0	0.1	30.0	Bar	IS-S	
PA25	Enabling of primary exchanger efficiency alarm	No (0)	No (0)	Yes (1)		IS-S	
PA26	Min. difference threshold for primary exchanger	2.0	0.1	20.0	°C	IS-S	
PA27	By-pass time for primary exchanger efficiency alarm	120	0	999	Sec.	IS-S	
PA30	Enable RTC alarm	Yes (1)	No (0)	Yes (1)		IS-S	
PA31	It sets the type of reset of RTC alarm restoration 0: Auto - Automatic 1: Manu - Manual	M	A (0)	M (1)		IS-S	
PA32	It sets the triggering delay connected with the free-cooling fan thermal alarm	10	0	999	Sec.	IS-S	
PA33	It sets the type of reset for the free-cooling fan thermal alarm 0: A - Automatic 1: M - Manual	M	A (0)	M (1)		IS-S	
PA40	It enables the alarm connected with operating hours of compressors	Yes (1)	No (0)	Yes (1)		IS-S	
PA41	It sets the triggering delay connected	10	0	999	Sec.	IS-S	



	with the compressor thermal alarm						
PA42	It sets the type of reset for the compressor thermal alarm 0: A - Automatic 1: M - Manual	M	A (0)	M (1)		IS-S	
PA50	Enable Source Flow alarm	No (0)	No (0)	Yes (1)		IS-S	Only for Water-Water unit
PA51	Source Flow alarm delay from machine start-up	10	1	999	Sec.	IS-S	Only for Water-Water unit
PA52	Source Flow alarm by-pass time during normal operation	1	1	999	Sec.	IS-S	Only for Water-Water unit
PA53	Minimum water valve opening to test the flow of the heat source exchanger	5.0%	0.0%	100.0%	%	IS-S	Only for Water-Water unit
PA60	It enables the alarm connected with operating hours of pumps	Yes (1)	No (0)	Yes (1)		IS-S	
PA61	It enables the alarm connected with operating hours of source pumps	No (0)	No (0)	Yes (1)		IS-S	Only for Water-Water unit
PA62	It sets the type of reset for the water pump thermal alarm 0: Auto - Automatic 1: Manu - Manual	M	A (0)	M (1)		IS-S	
PA63	It sets the type of reset for the source water pump thermal alarm 0: Auto - Automatic 1: Manu - Manual	M	A (0)	M (1)		IS-S	Only for Water-Water unit
PA71	It sets the type of reset of high pressure alarm restoration 0: Auto - Automatic 1: Manu - Manual	M	A (0)	M (1)		IS-S	
PA80	It enables the alarm connected with operating hours of condensing fans	Yes (1)	No (0)	Yes (1)		IS-S	
PA81	It sets the triggering delay connected with the condensing fan thermal alarm	10	0	999	Sec.	IS-S	
PA82	It sets the type of reset for the condensing fan thermal alarm 0: A - Automatic 1: M - Manual	M	A (0)	M (1)		IS-S	
PA85	Setpoint for the high temperature discharge gas alarm of circuit 1	90.0	70.0	140.0	°C	IS-S	
PA86	Differential for the high temperature discharge gas alarm of circuit 1	20.0	10.0	30.0	°C	IS-S	
PA87	It sets the triggering delay connected with the high temperature discharge gas	30	0	999	Sec.	IS-S	
PA88	It sets the type of reset for the high temperature discharge gas 0: A - Automatic 1: M - Manual	M	A (0)	M (1)		IS-S	

PA89	Setpoint for the high temperature discharge gas alarm of circuit 2	90.0	70.0	140.0	°C	IS-S	
PA90	Differential for the high temperature discharge gas alarm of circuit 2	20.0	10.0	30.0	°C	IS-S	
PA99	Notification delay interval for expansion alarm	5	0	999	Sec.	IS-S	
<b>MODBUS PARAMETERS</b>							
PH11	Card Modbus address	1	1	247		IS-M	
PH12	Card communication baud rate (1=2400, 2=4800, 3=9600, 4=19200)	3	1	4		IS-M	
PH13	Modbus parity (0=none, 1=Odd, 2=Even)	2	0	2		IS-M	
PH14	Modbus stop bit (0=1 bit, 1=2 bits)	0	0	1		IS-M	
<b>VARIOUS PARAMETERS</b>							
PH01	It sets the minimum full-scale value for the low pressure sensor.	0.0	-10.0	PH02	Bar	IS-V	
PH02	It sets the maximum full-scale value for the low pressure sensor.	20.0	PH01	60.0	Bar	IS-V	
PH03	It sets the minimum full-scale value for the high pressure sensor.	0.0	-10.0	PH04	Bar	IS-V	
PH04	It sets the maximum full-scale value for the high pressure sensor.	50.0	PH03	45.0	Bar	IS-V	
PH05	It enables the start-up/shutdown of the machine by pressing the ESC/Stand-By key.	Yes (1)	No (0)	Yes (1)		IS-V	
PH06	It enables the change of summer/winter operating mode: automatic change-over.	No (0)	No (0)	Yes (1)		IS-V	
PH07	It enables the start-up/shutdown of the machine from a digital input.	No (0)	No (0)	Yes (1)		IS-V	
PH08	It enables the change of summer/winter operating mode from digital input.	No (0)	No (0)	Yes (1)		IS-V	
PH09	It enables the start-up/shutdown of the machine by supervisor.	No (0)	No (0)	Yes (1)		IS-V	
PH10	It enables the change of summer/winter operating mode via supervisor.	No (0)	No (0)	Yes (1)		IS-V	
PH15	It resets the factory-set parameter defaults.	No (0)	No (0)	Yes (1)		IS-V	Wait for the 0 value to be re-read at the end of resetting.
PH16	It enables the start-up/shutdown of the machine by the schedule	No (0)	No (0)	Yes (1)		IS-V	
PH27	It sets the enabling of the dynamic set point function.	No (0)	No (0)	Yes (1)		IS-V	
PH28	It sets the enabling of the secondary set point function by scheduler.	No (0)	No (0)	Yes (1)		IS-V	
PH30	Cancel alarm history	NO (0)	NO (0)	YES (1)	-	IS-V	Set SI (1) and wait for value NO (0)
PH31	It sets the type of refrigerant used	5	0	6		IS-V	

	(temperature-pressure conversion). 0: No refrigerant 1: R22 2: R134a 3: R404A 4: R407C 5: R410A 6: R507	R410A					
PH32	It sets the temperature measurement unit: 0: ° Celsius 1: ° Fahrenheit	0 (°C)	0	1		IS-V	
PH33	It sets the pressure measurement unit: 0: Bar 1: psi	0 (Bar)	0	1		IS-V	
PH52	It enable the EVCO icon	1	0	1		IS-V	
PH53	It sets the meaning of the Summer and Winter icons. 0: Summer = Cooling (chiller mode) Winter = Heating (heat pump mode) 1: Summer = Heating (heat pump mode) Winter = Cooling (chiller mode)	0	0	1		IS-V	
PH90	Language	Eng	Eng	Ita		IS-V	
PH99	CANbus BaudRate: (1=20K; 2=50K; 3=125K; 4=500K)	2 (50K)	1	4		IS-V	
PSd3	It sets the Installation Operator level password.	0	-999	9999		IS-V	
<b>Level 4</b>	<b>CONFIGURATION MENU</b>						
	<b>CONFIGURATION</b>						
PGUT	Unit type setting	10	1	16		CO-W	
PG00	It sets the unit type: 1: Air-to-water chiller 2: Air-to-water chiller + heat pump 3: Water-to-water chiller 4: Water-to-water chiller + heat pump	1	1	4		CO-W	
PG01	Number of circuits	2	1	2		CO-W	
PG02	It enables the presence of the IO expansion.	Yes (1)	No (0)	Yes (1)		CO-W	
PG03	It sets the number of compressors per circuit.	3	1	3		CO-W	
PG04	Enable Real Time Clock-RTC	1	0	1		CO-W	
PG05	Enable the presence of the EVCM Modules (1 per circuit)	Yes (1)	No (0)	Yes (1)		CO-W	
PG09	It sets the number of pumps.	1	1	2		CO-W	
PG10	Sets the number of source pumps (for water-water unit)	1	1	2		CO-W	Only for Water-Water unit
PG11	It enables unique condensing: 0: No (2 fans)	No (0)	No (0)	Yes (1)		CO-W	For Water-Water

	1: Yes (1 fan)						unitdetermine s whether there are1/2 heat source exchangers
PG12	It enables single/twin exchangerusers: 0: No (2) 1: Yes (1)	Yes (1)	No (0)	Yes (1)		CO-W	Determines whether there are1/2heat sink exchangers
PG13	Set the type of free-cooling air circuit 0: Only with condensation 1: Separate with AO fan 2: Separate with DO fan	1	0	2		CO-W	Only for Chillers Air- Water unit
PG14	It enables single/twinexchangersource: 0: No (2) 1: Yes (1)	Yes (1)	No (0)	Yes (1)		CO-W	Determines whether there are 1/2heat source exchangers
PSd4	Constructor level password	0	-999	9999		CO	
<b>HARDWARE CONFIGURATION</b>							
HA01 HA02 HA03 HA07 HA08 HA09	They set the probes connected to analog inputs 1, 2, 3, 7, 8, 9 of the controller	3 4 13 0 0 0	0	68		CO-HW	See Table Config. AI
HA04 HA05 HA06	They set the probes connected to analog inputs 4,5,6 of the controller	10 0 0	0	56		CO-HW	
HA11 HA12 HA16 HA17 HA18 HA19	They set the probes connected to analog inputs 1, 2, 3, 7, 8, 9 of the expansion	15 11 0 0 0 0	0	68		CO-HW	
HA13 HA14 HA15	They set the probes connected to analog inputs4,5,6 of the expansion	0 0 0	0	56		CO-HW	
HB01 ... HB09	They set which digital resources to connect to the digital inputs of the controller	3 7 11 27 21 23 25 15 9	0	44		CO-HW	
HB10 ... HB18	They set which digital resources to connect to the digital inputs of the expansion	39 33 35 37 0 0 0	0	44		CO-HW	

		0						
		0						
HC01 HC02 HC03 HC04	They set which analog resources to connect to analog outputs 1, 2, 3, 4 of the controller	4 6 0 0	0	9		CO-HW	See Table Config. AO	
HC07 HC08 HC09 HC10	They set which analog resources to connect to analog outputs 1, 2, 3, 4 of the expansion	0 0 0 0	0	9		CO-HW		
HC05 HC06	They set which analog resources to connect to analog outputs 5, 6 of the controller	0 0	0	6		CO-HW		
HC11 HC12	They set which analog resources to connect to analog outputs 5, 6 of the expansion	0 0	0	6		CO-HW		
HCF1	It sets the frequency of the PWM function of theFree Cooling fan	1000	10	2000	Hz	CO-HW		
HCF2	It sets the frequency of the PWM function of the circuit 1 fan	1000	10	2000	Hz	CO-HW		
HCF3	It sets the frequency of the PWM function of the circuit 2 fan	1000	10	2000	Hz	CO-HW		
HD01 ... HD09	They set which digital resources to connect to the digital outputs of the controller	2 12 14 26 6 22 0 0 0	0	48		CO-HW	See Table Config. DO	
HD10 ... HD18	They set which digital resources to connect to the digital outputs of the expansion	30 32 40 0 0 0 0 0	0	48		CO-HW		
<b>ELECTRONIC VALVE MODULES</b>								
<b>EVDRIVE03 circuit 1</b>								
PV01	Setpoint SH (1)	6.0	3.0	25.0	K	CO-V		
PV02	Setpoint LoSH (1)	2.0	1.0	3.0	K	CO-V		
PV03	Setpoint HiSH (1)	15.0	10.0	40.0	K	CO-V		
PV04	Setpoint LOP (1)	-40.0	-40.0	40.0	K	CO-V		
PV05	Setpoint MOP (1)	40.0	-40.0	40.0	K	CO-V		
PV06	PID – proportional band (1)	7.0	1.0	100.0	K	CO-V		
PV07	PID – integraltme (1)	120	0	999	sec	CO-V		
PV08	PID – derivative time(1)	120	0	999	sec	CO-V		
PV09	Start-up delay (1)	5	1	255	sec	CO-V		
PV10	Start-up position (1)	50.00	0.00	100.00	%	CO-V		
PV11	Setpoint SH (2)	6.0	3.0	25.0	K	CO-V		
PV12	Setpoint LoSH (2)	2.0	1.0	3.0	K	CO-V		

PV13	Setpoint HiSH (2)	15.0	10.0	40.0	K	CO-V	
PV14	Setpoint LOP (2)	-40.0	-40.0	40.0	K	CO-V	
PV15	Setpoint MOP 2)	40.0	-40.0	40.0	K	CO-V	
PV16	PID –proportional band (2)	7.0	1.0	100.0	K	CO-V	
PV17	PID –integraltime (2)	120	0	999	sec	CO-V	
PV18	PID –derivativetime (2)	120	0	999	sec	CO-V	
PV19	Start-up delay (2)	5	1	255	sec	CO-V	
PV20	Start-up position (2)	50.00	0.00	100.00	%	CO-V	
PV21	Stabilization time	0	0	255	sec	CO-V	
PV22	Stabilization position	100.00	0.00	100.00	%	CO-V	
PV23	Operation mode: 0= SH algo 1= Manual	0	0	1		CO-V	
PV24	Manual position	0.00	0.00	100.00	%	CO-V	
PV25	SetSH parameters: 0= set1 1= set2	0	0	1		CO-V	
PV26	Relay function: 0= Disabled 1=Enabled: any alarm 2=Enabled: probe error 3= LoSH alarm 4= MOP alarm 5= valve alarm 6= solenoid valve 7= solenoid valve + alarms 8= resyncro	6	0	8		CO-V	
PV27	Probe type 3: 0= NTC 1= PT1000	0	0	1		CO-V	
PV28	Probe type 4: 0= 4..20mA (0.5 – 8) 1= 4..20mA (0 – 30) 2= 0-5V (0 – 7) 3= 0-5V (0 – 25) 4= 0-5V (0 – 60) 5= scaling	0	0	1		CO-V	
PV29	Probe type 1: 1= PTC 2= NTC 3= 0..20mA 4= 4..20mA 5= 0-5V 6= 0-10V 7= PT1000 8= NTC K2 9= NTC K3	5	1	9		CO-V	
PV30	Probe type 2: 1= PTC 2= NTC 3= 0..20mA 4= 4..20mA 5= 0-5V 6= 0-10V	2	1	9		CO-V	

	7= PT1000 8= NTC K2 9= NTC K3						
PV31	Ts offset	0.0	-10.0	10.0	K	CO-V	
PV32	Te offset	0.0	-10.0	10.0	K	CO-V	
PV34	Relay logic	N.O. (0)	N.O. (0)	N.C. (1)		CO-V	
PV35	DI1 logic	N.O. (0)	N.O. (0)	N.C. (1)		CO-V	
PV36	DI2 logic	N.O. (0)	N.O. (0)	N.C. (1)		CO-V	
PV37	DI3 logic	N.O. (0)	N.O. (0)	N.C. (1)		CO-V	
PV80	Enable Modulating Super-Heat Setpoint circuit 1	Yes (1)	No (0)	Yes (1)		CO-V	
PV81	Max Super-Heat circuit 1	15.0	3.0	25.0	°K	CO-V	
PV82	Min Super-Heat circuit 1	2.0	1.0	25.0	°K	CO-V	
PV83	Max discharge super-heat circuit 1	35.0	0.0	50.0	°K	CO-V	
PV84	Min discharge super-heat circuit 1	5.0	0.0	50.0	°K	CO-V	
<b>EVDRIIVE03 circuit 2</b>							
PV41	Setpoint SH (1)	6.0	3.0	25.0	K	CO-V	
PV42	Setpoint LoSH (1)	2.0	1.0	3.0	K	CO-V	
PV43	Setpoint HiSH (1)	15.0	10.0	40.0	K	CO-V	
PV44	Setpoint LOP (1)	-40.0	-40.0	40.0	K	CO-V	
PV45	Setpoint MOP (1)	40.0	-40.0	40.0	K	CO-V	
PV46	PID –proportional band(1)	7.0	1.0	100.0	K	CO-V	
PV47	PID –integraltime (1)	120	0	999	sec	CO-V	
PV48	PID –derivativetime (1)	120	0	999	sec	CO-V	
PV49	Start-up delay (1)	5	1	255	sec	CO-V	
PV50	Start-up position (1)	50.00	0.00	100.00	%	CO-V	
PV51	Setpoint SH (2)	6.0	3.0	25.0	K	CO-V	
PV52	Setpoint LoSH (2)	2.0	1.0	3.0	K	CO-V	
PV53	Setpoint HiSH (2)	15.0	10.0	40.0	K	CO-V	
PV54	Setpoint LOP (2)	-40.0	-40.0	40.0	K	CO-V	
PV55	Setpoint MOP 2)	40.0	-40.0	40.0	K	CO-V	
PV56	PID –proportional band (2)	7.0	1.0	100.0	K	CO-V	
PV57	PID –integral time (2)	120	0	999	sec	CO-V	
PV58	PID –derivative time (2)	120	0	999	sec	CO-V	
PV59	Start-up delay (2)	5	1	255	sec	CO-V	
PV60	Start-up position (2)	50.00	0.00	100.00	%	CO-V	
PV61	Stabilization time	0	0	255	sec	CO-V	
PV62	Stabilization position	100.00	0.00	100.00	%	CO-V	
PV63	Operation mode: 0= SH algo 1= Manual	0	0	1		CO-V	
PV64	Manual position	0.00	0.00	100.00	%	CO-V	
PV65	SetSH parameters: 0= set1 1= set2	0	0	1		CO-V	
PV66	Relay function: 0=Disabled 1= Enabled:any alarm 2=Enabled:probe error 3= LoSH alarm 4= MOP alarm 5= valve alarm	6	0	8		CO-V	

	6= solenoid valve 7= solenoid valve + alarms 8= resyncro						
PV67	Probe type 3: 0= NTC 1= PT1000	0	0	1		CO-V	
PV68	Probe type 4: 0= 4..20mA (0.5 - 8) 1= 4..20mA (0 - 30) 2= 0-5V (0 - 7) 3= 0-5V (0 - 25) 4= 0-5V (0 - 60) 5= scaling	0	0	1		CO-V	
PV69	Probe type 1: 1= PTC 2= NTC 3= 0..20mA 4= 4..20mA 5= 0-5V 6= 0-10V 7= PT1000 8= NTC K2 9= NTC K3	5	1	9		CO-V	
PV70	Probe type 2: 1= PTC 2= NTC 3= 0..20mA 4= 4..20mA 5= 0-5V 6= 0-10V 7= PT1000 8= NTC K2 9= NTC K3	2	1	9		CO-V	
PV71	Ts offset	0.0	-10.0	10.0	K	CO-V	
PV72	Te offset	0.0	-10.0	10.0	K	CO-V	
PV74	Relay logic	N.O. (0)	N.O. (0)	N.C. (1)		CO-V	
PV75	DI1 logic	N.O. (0)	N.O. (0)	N.C. (1)		CO-V	
PV76	DI2 logic	N.O. (0)	N.O. (0)	N.C. (1)		CO-V	
PV77	DI3 logic	N.O. (0)	N.O. (0)	N.C. (1)		CO-V	
PV89	Enable Modulating Super-Heat Setpoint circuit 2	Yes (1)	No (0)	Yes (1)		CO-V	
PV85	Max Super-Heat circuit 2	15.0	3.0	25.0	°K	CO-V	
PV86	Min Super-Heat circuit 2	2.0	1.0	25.0	°K	CO-V	
PV87	Max discharge super-heat circuit 2	35.0	0.0	50.0	°K	CO-V	
PV88	Min discharge super-heat circuit 2	5.0	0.0	50.0	°K	CO-V	

**Note:** Once the machine parameters have been configured, and every time the configuration parameters are modified, it is advisable to shut down the machine and restart the plant, to enable the card to reconfigure itself correctly.



## 7.2 AI Configuration (HA01-HA18 parameters)

Below is a table of values for configuring the positions of the analog inputs of the controller and of the expansion. The analog inputs can be configured as digital inputs as well.

Parameters		Analog Inputs
HA01-HA03; HA07-HA09 HA11-HA13; HA17-HA19	HA04-HA06 HA14-HA16	
0	0	Disabled
1	1	External ambient temperature
2	2	System entering temperature (Free Cooling)
3	3	Heat sink entering temperature
4	4	Circuit 1 heat sink exchanger entering temperature
5	5	Circuit 2 heat sink exchanger leaving temperature
6	6	Circuit 1 heat source exchanger leaving temperature
7	7	Circuit 2 heat source exchanger leaving temperature
8	8	Circuit 1 coil temperature
9	9	Circuit 2 coil temperature
10	10	Circuit 1 compressor discharge temperature
11	11	Circuit 2 compressor discharge temperature
12	12	Remote temperature (Accumulation tank)
13	-	Circuit 1 condensing pressure (4-20mA)
14	-	Circuit 1 condensing pressure (0-5V)
15	-	Circuit 2 condensing pressure (4-20mA)
16	-	Circuit 2 condensing pressure (0-5V)
17	-	Circuit 1 evaporation pressure (4-20mA)
18	-	Circuit 1 evaporation pressure (0-5V)
19	-	Circuit 2 evaporation pressure (4-20mA)
20	-	Circuit 2 evaporation pressure (0-5V)
21	-	Circuit 1 single pressure (4-20mA)
22	-	Circuit 1 single pressure (0-5V)
23	-	Circuit 2 single pressure (4-20mA)
24	-	Circuit 2 single pressure (0-5V)
25-26	13-14	Summer/Winter NC-NO
27-28	15-16	On/Off NC-NO
29-30	17-18	Set point NC-NO change
31-32	19-20	Heat sinkexchanger flow meter NC-NO
33-34	21-22	Heat source exchanger flow meter NC-NO
35-36	23-24	Heat sink exchanger NC-NOheat pump 1
37-38	25-26	Heat sink exchanger NC-NO heat pump 2
39-40	27-28	Heat source exchanger NC-NO heat pump 1
41-42	29-30	Heat source exchanger NC-NO heat pump 2
43-44	31-32	Free Cooling externalheater fan NC-NO
45-46	33-34	High pressureCircuit 1 NC-NO
47-48	35-36	Low pressureCircuit 1 NC-NO
49-50	37-38	Thermal compressor 1 NC-NO
51-52	39-40	Thermal compressor 2 NC-NO
53-54	41-42	Thermal compressor 3 NC-NO
55-56	43-44	Circuit 1 NC-NO heater fan
57-58	45-46	High pressureCircuit 2 NC-NO
59-60	47-48	Low pressureCircuit 2 NC-NO
61-62	49-50	Thermal compressor 4 NC-NO
63-64	51-52	Thermal compressor 5 NC-NO
65-66	53-54	Thermal compressor 6 NC-NO
67-68	55-56	Circuit 2 NC-NO heater fan

### 7.3 DI Configuration(HB01-HB18 parameters)

Below is a table of values for configuring the positions of the digital inputs of the controller and of the expansion.

HB01-HB18 Parameters	Digital Inputs
0	Disabled
1-2	Summer/Winter NC-NO
3-4	On/Off NC-NO
5-6	Set point change NC-NO
7-8	Heat sink exchanger flow meter NC-NO
9-10	Heat source exchanger flow meter NC-NO
11-12	Heat sink exchanger Heat pump 1 NC-NO
13-14	Heat sink exchanger Heat pump 2 NC-NO
15-16	Heat source exchanger Heat pump 1 NC-NO
17-18	Heat source exchanger Heat pump 2 NC-NO
19-20	Free Cooling external heater fan NC-NO
21-22	High pressure Circuit 1 NC-NO
23-24	Low pressure Circuit 1 NC-NO
25-26	Thermal compressor 1 NC-NO
27-28	Thermal compressor 2 NC-NO
29-30	Thermal compressor 3 NC-NO
31-32	Circuit1 heater fan NC-NO
33-34	High pressureCircuit 2 NC-NO
35-36	Low pressureCircuit 2 NC-NO
37-38	Thermal compressor 4 NC-NO
39-40	Thermal compressor 5 NC-NO
41-42	Thermal compressor 6 NC-NO
43-44	Circuit 2 heater fanNC-NO

### 7.4 AO Configuration (HC01-HC18 parameters)

Below is a table of values for configuring the positions of the analog outputs of the controller and of the expansion.

Parameters			Analog Outputs
HC01 HC02 HC07 HC08	HC03 HC04 HC09 HC10	HC05 HC06 HC11 HC12	
0	0	0	Disabled
1	1	1	Free Cooling 3-way valve (0-10V)
2	2	2	Free Cooling external fan(0-10V)
3	3	3	Circuit 1 ventilation (0-10V)
4	4	4	Circuit 1 water valve (0-10V)
5	5	5	Circuit 2 ventilation (0-10V)
6	6	6	Circuit 2 water valve (0-10V)
7	-	-	Free Cooling external fan (PWM)
8	-	-	Circuit 1 ventilation(PWM)
9	-	-	Circuit 2 ventilation(PWM)
-	7	-	Free Cooling external fan (4-20mA)
-	8	-	Circuit 1 ventilation (4-20mA)
-	9	-	Circuit 2 ventilation (4-20mA)

## 7.5 DO Configuration (HD01-HD18 parameters)

Below is a table of values for configuring the positions of the digital outputs of the controller and of the expansion.

Parameters HD01-HD18	Digital Outputs
0	Disabled
1-2	Heat sink pump 1 NC-NO
3-4	Heat sink pump 2 NC-NO
5-6	Heat source pump 1 NC-NO
7-8	Heat source pump 2 NC-NO
9-10	Free Cooling external fan NC-NO (On/Off or Enabling)
11-12	Compressor 1 NC-NO
13-14	Compressor 2 NC-NO
15-16	Compressor 3 NC-NO
17-18	Circuit 1 reversing valve NC-NO
19-20	Circuit 1 fan step (enabling) NC-NO
21-22	Circuit 1 solenoid valve NC-NO
23-24	Circuit 1 coil splitter valve (Free Cooling) NC-NO
25-26	Circuit 1 heat sink exchanger anti-frost resistance NC-NO
27-28	Circuit 1 heat source exchanger anti-frost resistance NC-NO
29-30	Compressor 4 NC-NO
31-32	Compressor 5 NC-NO
33-34	Compressor 6 NC-NO
35-36	Circuit 2 reversing valve NC-NO
37-38	Circuit 2 fan step (enabling) NC-NO
39-40	Circuit 2 solenoid valve NC-NO
41-42	Circuit 2 coil splitter valve (Free Cooling) NC-NO
43-44	Circuit 2 heat sink exchanger anti-frost resistance NC-NO
45-46	Circuit 2 heat source exchanger anti-frost resistance NC-NO
47-48	On/Off Free Cooling valve NC-NO

## 8 REGULATIONS

### 8.1 Machine Status

Several procedures exist for switching the unit ON and OFF:

- 1) Using the dedicated ON/OFF key (this function is enabled via parameter PH05).  
Switching ON – Press the dedicated key for about 2 seconds: if all other enabled functions are present, the machine switches itself ON. Switching OFF – Press the dedicated key for about 2 seconds: the machine switches itself OFF.
  
- 2) Using the ON/OFF command from digital input (this function is enabled via parameter PH07).  
Switching ON – Close the remote ON/OFF contact: if all other enabled functions are present, the machine switches itself ON.  
Switching OFF – If the remote ON/OFF contact reveals itself to be open, the machine switches itself "OFF from digital input", which is indicated by "OFF D".
  
- 3) Using a supervisory protocol (this function is enabled via parameter PH09).  
Switching ON – Activate via protocol the switching ON status: if all other enabled functions are present, the machine switches itself ON. Switching OFF – If the ON status is disabled via protocol, the machine switches itself "OFF by supervisory protocol", which is indicated by "OFF S".
  
- 4) Using a schedule (this function is enabled via parameter PH16).  
Switching ON – If the date and time of the RTC indicates an ON status: if all other enabled functions are present, the machine switches itself ON. Switching OFF – If the date and time of the RTC indicates an OFF status; the machine switches itself OFF.

OFF statuses from digital input, supervisory protocol and schedule are only accessible if the machine has been enabled by key press.  
The machine ON/OFF key is the ESC key.

## 8.2 Unit Type

With the machine in OFF status, using the **PGUT** parameter from the CONSTRUCTOR/CONFIGURATION menu, it is possible to select the unit type to be used. Control and other parameters corresponding to the various functions must be manually modified according to user requirements. All the default unit have 2 compressors for each circuit.

Managed machines are listed below, together with their respective input and output configurations.

### 8.2.1 Water-To-Water Chiller with EVDRIVE03

	PGUT=1(1 Circuit)	PGUT=9(2 Circuit)
<b>Controller Analog Inputs</b>		
A/I 1	Heat sink exchanger input temperature	Heat sink exchanger input temperature
A/I 2	Heat sink exchanger output temperature	Heat sink exchanger output temperature
<b>Analog InputsEVDRIVE03 circuit 1</b>		
A/I 1	Condensing pressure C1 (4-20mA)	Condensing pressure C1 (4-20mA)
A/I 2	Compressor discharge temperatureC1	Compressor discharge temperature C1
A/I 3	Compressor intake temperatureC1	Compressor intake temperature C1
A/I 4	Evaporation pressure C1 (4-20mA)	Evaporation pressure C1 (4-20mA)
<b>Analog Inputs EVDRIVE03 circuit 2</b>		
A/I 1	<i>Not present</i>	Condensing pressure (4-20mA) C2
A/I 2	<i>Not present</i>	Compressor discharge temperature C2
A/I 3	<i>Not present</i>	Compressor intake temperature C2
A/I 4	<i>Not present</i>	Evaporation pressure (4-20mA) C2
<b>Controller Digital Inputs</b>		
D/I 1	On/Off	On/Off
D/I 2	Heat sink exchanger flow meter	Heat sink exchanger flow meter
D/I 3	Heat sink heat pump 1	Heat sink heat pump 1
D/I 4	Thermal compressor 2	Thermal compressor 2
D/I 5	Heat source heat pump 1	Heat source heat pump 1
D/I 6	Heat source exchanger flow meter	Heat source exchanger flow meter
D/I 7	<i>Not used</i>	Thermal compressor 5
<b>Digital InputsEVDRIVE03 circuit 1</b>		
D/I 1	High pressure C1	High pressure C1
D/I 2	Low pressure C1	Low pressure C1
D/I 3	Thermal compressor 1	Thermal compressor 1
<b>Digital InputsEVDRIVE03 circuit 2</b>		
D/I 1	<i>Not present</i>	High pressure C2
D/I 2	<i>Not present</i>	Low pressure C2
D/I 3	<i>Not present</i>	Thermal compressor4
<b>Controller Analog Outputs</b>		
A/O 1	Water valve C1 (0-10V)	Water valve C1 (0-10V)
A/O 2	<i>Not used</i>	Water valve C2 (0-10V)
<b>Controller Digital Outputs</b>		
D/O 1	Heat sink pump 1	Heat sink pump 1
D/O 2	Compressor 1	Compressor 1
D/O 3	Compressor 2	Compressor 2
D/O 4	Heat sink anti-frost resistance C1	Heat sink anti-frost resistance C1
D/O 5	Source pump	Source pump
D/O 6	<i>Not used</i>	Compressor 4
D/O 7	<i>Not used</i>	Compressor5
<b>Digital OutputsEVDRIVE03 circuit 1</b>		
D/O VCM 1	Solenoid valve C1	Solenoid valve C1
<b>Digital OutputsEVDRIVE03 circuit 2</b>		
D/O VCM 2	<i>Not present</i>	Solenoid valve C2

### 8.2.2 Water-To-Water Chiller

	PGUT=2 (1 Circuit)	PGUT=10 (2 Circuit)
<b>Controller Analog Inputs</b>		
A/I 1	Heat sink exchanger input temperature	Heat sink exchanger input temperature
A/I 2	Heat sink exchanger output temperature	Heat sink exchanger output temperature
A/I 3	Condensing pressure C1 (4-20mA)	Condensing pressure C1 (4-20mA)
A/I 4	Compressor discharge temperature C1	Compressor discharge temperature C1
<b>Expansion Analog Inputs</b>		
A/I 1	<i>Not present</i>	Condensing pressure C2 (4-20mA)
A/I 2	<i>Not present</i>	Compressor discharge temperature C2
<b>Controller Digital Inputs</b>		
D/I 1	On/Off	On/Off
D/I 2	Heat sink exchanger flow meter	Heat sink exchanger flow meter
D/I 3	Heat sink heat pump 1	Heat sink heat pump 1
D/I 4	Thermal compressor 2	Thermal compressor 2
D/I 5	High pressure C1	High pressure C1
D/I 6	Low pressure C1	Low pressure C1
D/I 7	Thermal compressor 1	Thermal compressor 1
D/I 8	Heat source heat pump 1	Heat source heat pump 1
D/I 9	Heat source exchanger flow meter	Heat source exchanger flow meter
<b>Expansion Digital Inputs</b>		
D/I 1	<i>Not present</i>	Thermal compressor 5
D/I 2	<i>Not present</i>	High pressure C2
D/I 3	<i>Not present</i>	Low pressure C2
D/I 4	<i>Not present</i>	Thermal compressor 4
<b>Controller Analog Outputs</b>		
A/O 1	Water valve C1 (0-10V)	Water valve C1 (0-10V)
A/O 2	<i>Not used</i>	Water valve C2 (0-10V)
<b>Expansion Analog Outputs</b>		
A/O	<i>Not present</i>	<i>Not used</i>
<b>Controller Digital Outputs</b>		
D/O 1	Heat sink pump 1	Heat sink pump 1
D/O 2	Compressor 1	Compressor 1
D/O 3	Compressor 2	Compressor 2
D/O 4	Heat sink anti-frost resistance C1	Heat sink anti-frost resistance C1
D/O 5	Heat source pump	Heat source pump
D/O 6	Solenoid valve C1	Solenoid valve C1
<b>Expansion Digital Outputs</b>		
D/O 1	<i>Not present</i>	Compressor 4
D/O 2	<i>Not present</i>	Compressor 5
D/O 3	<i>Not present</i>	Solenoid valve C2

## 8.2.3 Water-To-Water Chiller+Heat Pump with EVDRIVE03

	PGUT=3 (1 Circuit)	PGUT=11 (2 Circuit)
<b>Controller Analog Inputs</b>		
A/I 1	Heat sink exchanger input temperature	Heat sink exchanger input temperature
A/I 2	Heat sink exchanger output temperature	Heat sink exchanger output temperature
A/I 3	Heat source exchanger output temperature	Heat source exchanger output temperature
<b>Expansion Analog Inputs</b>		
A/I	<i>Not present</i>	<i>Not used</i>
<b>Analog Inputs EVDRIVE03 circuit 1</b>		
A/I 1	Condensing pressure C1 (4-20mA)	Condensing pressure C1 (4-20mA)
A/I 2	Compressor discharge temperature C1	Compressor discharge temperature C1
A/I 3	Compressor intake temperature C1	Compressor intake temperature C1
A/I 4	Evaporation pressure C1 (4-20mA)	Evaporation pressure C1 (4-20mA)
<b>Analog Inputs EVDRIVE03 circuit 2</b>		
A/I 1	<i>Not present</i>	Condensing pressure (4-20mA) C2
A/I 2	<i>Not present</i>	Compressor discharge temperature C2
A/I 3	<i>Not present</i>	Compressor intake temperature C2
A/I 4	<i>Not present</i>	Evaporation pressure (4-20mA) C2
<b>Controller Digital Inputs</b>		
D/I 1	On/Off	On/Off
D/I 2	Heat sink exchanger flow meter	Heat sink exchanger flow meter
D/I 3	Heat sink heat pump 1	Heat sink heat pump 1
D/I 4	Thermal compressor 2	Thermal compressor 2
D/I 5	Heat source heat pump 1	Heat source heat pump 1
D/I 6	Summer/Winter	Summer/Winter
D/I 7	Heat source exchanger flow meter	Heat source exchanger flow meter
<b>Expansion Digital Inputs</b>		
D/I 1	<i>Not present</i>	Thermal compressor 5
<b>Digital Inputs EVDRIVE03 circuit 1</b>		
D/I 1	High pressure C1	High pressure C1
D/I 2	Low pressure C1	Low pressure C1
D/I 3	Thermal compressor 1	Thermal compressor 1
<b>Digital Inputs EVDRIVE03 circuit 2</b>		
D/I 1	<i>Not present</i>	High pressure C2
D/I 2	<i>Not present</i>	Low pressure C2
D/I 3	<i>Not present</i>	Thermal compressor 4
<b>Controller Analog Outputs</b>		
A/O 1	Water valve C1 (0-10V)	Water valve C1 (0-10V)
A/O 2	<i>Not used</i>	Water valve C2 (0-10V)
<b>Expansion Analog Outputs</b>		
A/O	<i>Not present</i>	<i>Not used</i>
<b>Controller Digital Outputs</b>		
D/O 1	Heat sink pump 1	Heat sink pump 1
D/O 2	Compressor 1	Compressor 1
D/O 3	Compressor 2	Compressor 2
D/O 4	Heat sink anti-frost resistance C1	Heat sink anti-frost resistance C1
D/O 5	Heat source pump	Heat source pump
D/O 6	Reversing valve C1	Reversing valve C1
D/O 7	Heat source anti-frost resistance C1	Heat source anti-frost resistance C1
<b>Expansion Digital Outputs</b>		
D/O 1	<i>Not present</i>	Compressor 4

D/O 2	<i>Not present</i>	Compressor 5
D/O 3	<i>Not present</i>	Reversing valve C2
<b>Digital OutputsEVDRIVE03 circuit 1</b>		
D/O VCM 1	Solenoid valve C1	Solenoid valve C1
<b>Digital OutputsEVDRIVE03 circuit 2</b>		
D/O VCM 2	<i>Not present</i>	Solenoid valve C2

#### 8.2.4 Water-To-Water Chiller+Heat Pump

	PGUT=4 (1 Circuit)	PGUT=12 (2 Circuit)
<b>Controller Analog Inputs</b>		
A/I 1	Heat sink exchanger input temperature	Heat sink exchanger input temperature
A/I 2	Heat sink exchanger output temperature	Heat sink exchanger output temperature
A/I 3	Single pressure (4-20mA) C1	Single pressure (4-20mA) C1
A/I 4	Compressor discharge temperature C1	Compressor discharge temperature C1
A/I 5	Heat source exchanger output temperature	Heat source exchanger output temperature
A/I 6	Heat source exchanger flow meter	<i>Not used</i>
<b>Expansion Analog Inputs</b>		
A/I 1	<i>Not present</i>	Single pressure (4-20mA) C2
A/I 2	<i>Not present</i>	Compressor discharge temperature C2
<b>Controller Digital Inputs</b>		
D/I 1	On/Off	On/Off
D/I 2	Heat sink exchanger flow meter	Heat sink exchanger flow meter
D/I 3	Heat sink heat pump 1	Heat sink heat pump 1
D/I 4	Thermal compressor 2	Thermal compressor 2
D/I 5	High pressure C1	High pressure C1
D/I 6	Low pressure C1	Low pressure C1
D/I 7	Thermal compressor 1	Thermal compressor 1
D/I 8	Heat source heat pump 1	Heat source heat pump 1
D/I 9	Summer/Winter	Summer/Winter
<b>Expansion Digital Inputs</b>		
D/I 1	<i>Not present</i>	Thermal compressor 5
D/I 2	<i>Not present</i>	High pressure C2
D/I 3	<i>Not present</i>	Low pressure C2
D/I 4	<i>Not present</i>	Thermal compressor 4
D/I 5	<i>Not present</i>	Heat source exchanger flow meter
<b>Controller Analog Outputs</b>		
A/O 1	Water valveC1 (0-10V)	Water valveC1 (0-10V)
A/O 2	<i>Not used</i>	Water valveC2 (0-10V)
<b>Expansion Analog Outputs</b>		
A/O	<i>Not present</i>	<i>Not used</i>
<b>Controller Digital Outputs</b>		
D/O 1	Heat sink heat pump 1	Heat sink heat pump 1
D/O 2	Compressor 1	Compressor 1
D/O 3	Compressor 2	Compressor 2
D/O 4	Heat sink anti-frost resistance C1	Heat sink anti-frost resistance C1
D/O 5	Heat source pump	Heat source pump
D/O 6	Solenoid valve C1	Solenoid valve C1
D/O 7	Reversing valve C1	Reversing valve C1
D/O 8	Heat source anti-frost resistance C1	Heat source anti-frost resistance C1
<b>Expansion Digital Outputs</b>		
D/O 1	<i>Not present</i>	Compressor 4
D/O 2	<i>Not present</i>	Compressor 5



<b>D/O 3</b>	<i>Not present</i>	Reversing valve C2
<b>D/O 4</b>	<i>Not present</i>	Solenoid valve C2

**8.2.5 Air-To-Water Chiller with EVDRIVE03**

	<b>PGUT=5 (1 Circuit)</b>	<b>PGUT=13 (2 Circuit)</b>
<b>Controller Analog Inputs</b>		
<b>A/I 1</b>	Heat sink exchanger input temperature	Heat sink exchanger input temperature
<b>A/I 2</b>	Heat sink exchanger output temperature	Heat sink exchanger output temperature
<b>Analog Inputs EVDRIVE03 circuit 1</b>		
<b>A/I 1</b>	Condensing pressure C1 (4-20mA)	Condensing pressure C1 (4-20mA)
<b>A/I 2</b>	Compressor discharge temperature C1	Compressor discharge temperature C1
<b>A/I 3</b>	Compressor intake temperature C1	Compressor intake temperature C1
<b>A/I 4</b>	Evaporation pressure C1 (4-20mA)	Evaporation pressure C1 (4-20mA)
<b>Analog Inputs EVDRIVE03 circuit 2</b>		
<b>A/I 1</b>	<i>Not present</i>	Condensing pressure (4-20mA) C2
<b>A/I 2</b>	<i>Not present</i>	Compressor discharge temperature C2
<b>A/I 3</b>	<i>Not present</i>	Compressor intake temperature C2
<b>A/I 4</b>	<i>Not present</i>	Evaporation pressure (4-20mA) C2
<b>Controller Digital Inputs</b>		
<b>D/I 1</b>	On/Off	On/Off
<b>D/I 2</b>	Heat sink exchanger flow meter	Heat sink exchanger flow meter
<b>D/I 3</b>	Heat sink heat pump 1	Heat sink heat pump 1
<b>D/I 4</b>	Thermal compressor 2	Thermal compressor 2
<b>D/I 5</b>	Heater fan C1	Heater fan C1
<b>D/I 6</b>	<i>Not used</i>	Thermal compressor 5
<b>Digital Inputs EVDRIVE03 circuit 1</b>		
<b>D/I 1</b>	High pressure C1	High pressure C1
<b>D/I 2</b>	Low pressure C1	Low pressure C1
<b>D/I 3</b>	Thermal compressor 1	Thermal compressor 1
<b>Digital Inputs EVDRIVE03 circuit 2</b>		
<b>D/I 1</b>	<i>Not present</i>	High pressure C2
<b>D/I 2</b>	<i>Not present</i>	Low pressure C2
<b>D/I 3</b>	<i>Not present</i>	Thermal compressor 4
<b>Controller Analog Outputs</b>		
<b>A/O 1</b>	Ventilation C1 (PWM)	Ventilation C1 (PWM)
<b>A/O 2</b>	<i>Not used</i>	Ventilation C2 (PWM)
<b>Controller Digital Outputs</b>		
<b>D/O 1</b>	Heat sink pump 1	Heat sink pump 1
<b>D/O 2</b>	Compressor 1	Compressor 1
<b>D/O 3</b>	Compressor 2	Compressor 2
<b>D/O 4</b>	Heat sink anti-frost resistance C1	Heat sink anti-frost resistance C1
<b>D/O 5</b>	Ventilation C1 (Enabling)	Ventilation C1 (Enabling)
<b>D/O 6</b>	<i>Not used</i>	Compressor 4
<b>D/O 7</b>	<i>Not used</i>	Compressor 5
<b>D/O 8</b>	<i>Not used</i>	Ventilation C2 (Enabling)
<b>Digital Outputs EVDRIVE03 circuit 1</b>		
<b>D/O VCM 1</b>	Solenoid valve C1	Solenoid valve C1
<b>Digital Outputs EVDRIVE03 circuit 2</b>		
<b>D/O VCM 2</b>	<i>Not present</i>	Solenoid valve C2

## 8.2.6 Air-To-Water Chiller

	PGUT=6 (1 Circuit)	PGUT=14 (2 Circuit)
<b>Controller Analog Inputs</b>		
A/I 1	Heat sink exchanger input temperature	Heat sink exchanger input temperature
A/I 2	Heat sink exchanger output temperature	Heat sink exchanger output temperature
A/I 3	Condensing pressure C1 (4-20mA)	Condensing pressure C1 (4-20mA)
A/I 4	Compressor discharge temperature C1	Compressor discharge temperature C1
<b>Expansion Analog Inputs</b>		
A/I 1	<i>Not present</i>	Condensing pressure C2 (4-20mA)
A/I 2	<i>Not present</i>	Compressor discharge temperature C2
<b>Controller Digital Inputs</b>		
D/I 1	On/Off	On/Off
D/I 2	Heat sink exchanger flow meter	Heat sink exchanger flow meter
D/I 3	Heat sink heat pump 1	Heat sink heat pump 1
D/I 4	Thermal compressor 2	Thermal compressor 2
D/I 5	High pressure C1	High pressure C1
D/I 6	Low pressure C1	Low pressure C1
D/I 7	Thermal compressor 1	Thermal compressor 1
D/I 8	Heater fan C1	Heater fan C1
<b>Expansion Digital Inputs</b>		
D/I 1	<i>Not present</i>	Thermal compressor 5
D/I 2	<i>Not present</i>	High pressure C2
D/I 3	<i>Not present</i>	Low pressure C2
D/I 4	<i>Not present</i>	Thermal compressor 4
<b>Controller Analog Outputs</b>		
A/O 1	Ventilation C1 (PWM)	Ventilation C1 (PWM)
A/O 2	<i>Not used</i>	Ventilation C2 (PWM)
<b>Expansion Analog Outputs</b>		
A/O	<i>Not present</i>	<i>Not used</i>
<b>Controller Digital Outputs</b>		
D/O 1	Heat sink pump 1	Heat sink pump 1
D/O 2	Compressor 1	Compressor 1
D/O 3	Compressor 2	Compressor 2
D/O 4	Heat sink anti-frost resistance C1	Heat sink anti-frost resistance C1
D/O 5	Ventilation C1 (Enabling)	Ventilation C1 (Enabling)
D/O 6	Solenoid valve C1	Solenoid valve C1
D/O 7	<i>Not used</i>	<i>Not used</i>
D/O 8	<i>Not used</i>	<i>Not used</i>
<b>Expansion Digital Outputs</b>		
D/O 1	<i>Not present</i>	Compressor 4
D/O 2	<i>Not present</i>	Compressor 5
D/O 3	<i>Not present</i>	Ventilation C2 (Enabling)
D/O 4	<i>Not present</i>	Solenoid valve C2

## 8.2.7 Air-To-Water Chiller+Heat Pump with EVDRIVE03

	PGUT=7 (1 Circuit)	PGUT=15 (2 Circuit)
<b>Controller Analog Inputs</b>		
A/I 1	Heat sink exchanger input temperature	Heat sink exchanger input temperature
A/I 2	Heat sink exchanger output temperature	Heat sink exchanger output temperature
A/I 3	External ambient temperature	External ambient temperature
<b>Expansion Analog Inputs</b>		
A/I	<i>Not present</i>	<i>Not used</i>
<b>Analog InputsEVDRIVE03 circuit 1</b>		
A/I 1	Condensing pressure C1 (4-20mA)	Condensing pressure C1 (4-20mA)
A/I 2	Compressor discharge temperature C1	Compressor discharge temperature C1
A/I 3	Compressor intake temperature C1	Compressor intake temperature C1
A/I 4	Evaporation pressure C1 (4-20mA)	Evaporation pressure C1 (4-20mA)
<b>Analog InputsEVDRIVE03 circuit 2</b>		
A/I 1	<i>Not present</i>	Condensing pressure (4-20mA) C2
A/I 2	<i>Not present</i>	Compressor discharge temperature C2
A/I 3	<i>Not present</i>	Compressor intake temperature C2
A/I 4	<i>Not present</i>	Evaporation pressure (4-20mA) C2
<b>Controller Digital Inputs</b>		
D/I 1	On/Off	On/Off
D/I 2	Heat sink exchanger flow meter	Heat sink exchanger flow meter
D/I 3	Heat sink heat pump 1	Heat sink heat pump 1
D/I 4	Thermal compressor 2	Thermal compressor 2
D/I 5	Heater fan C1	Heater fan C1
D/I 6	Summer/Winter	Summer/Winter
<b>Expansion Digital Inputs</b>		
D/I 1	<i>Not present</i>	Thermal compressor 5
<b>Digital InputsEVDRIVE03 circuit 1</b>		
D/I 1	High pressure C1	High pressure C1
D/I 2	Low pressure C1	Low pressure C1
D/I 3	Thermal compressor 1	Thermal compressor 1
<b>Digital InputsEVDRIVE03 circuit 2</b>		
D/I 1	<i>Not present</i>	High pressure C2
D/I 2	<i>Not present</i>	Low pressure C2
D/I 3	<i>Not present</i>	Thermal compressor 4
<b>Controller Analog Outputs</b>		
A/O 1	Ventilation C1 (PWM)	Ventilation C1 (PWM)
A/O 2	<i>Not used</i>	Ventilation C2 (PWM)
<b>Expansion Analog Outputs</b>		
A/O	<i>Not present</i>	<i>Not used</i>
<b>Controller Digital Outputs</b>		
D/O 1	Heat sink pump 1	Heat sink pump 1
D/O 2	Compressor 1	Compressor 1
D/O 3	Compressor 2	Compressor 2
D/O 4	Heat sink anti-frost resistance C1	Heat sink anti-frost resistance C1
D/O 5	Ventilation C1 (Enabling)	Ventilation C1 (Enabling)
D/O 6	Reversing valve C1	Reversing valveC1
<b>Expansion Digital Outputs</b>		
D/O 1	<i>Not present</i>	Compressor 4
D/O 2	<i>Not present</i>	Compressor 5
D/O 3	<i>Not present</i>	Compressor C2 (Enabling)

D/O 4	Not present	Reversing valve C2
<b>Digital Outputs EVDRIVE03 circuit 1</b>		
D/O VCM 1	Solenoid valve C1	Solenoid valve C1
<b>Digital Outputs EVDRIVE03 circuit 2</b>		
D/O VCM 2	Not present	Solenoid valve C2

### 8.2.8 Air-To-Water Chiller+Heat Pump

	PGUT=8 (1 Circuit)	PGUT=16 (2 Circuit)
<b>Controller Analog Inputs</b>		
A/I 1	Heat sink exchanger input temperature	Heat sink exchanger input temperature
A/I 2	Heat sink exchanger output temperature	Heat sink exchanger output temperature
A/I 3	Single pressure C1 (4-20mA)	Single pressure C1 (4-20mA)
A/I 4	Compressor discharge temperature C1	Compressor discharge temperature C1
A/I 5	External ambient temperature	External ambient temperature
<b>Expansion Analog Inputs</b>		
A/I 1	Not present	Single pressure C2 (4-20mA)
A/I 2	Not present	Compressor discharge temperature C2
<b>Controller Digital Inputs</b>		
D/I 1	On/Off	On/Off
D/I 2	Heat sink exchanger flow meter	Heat sink exchanger flow meter
D/I 3	Heat sink heat pump 1	Heat sink heat pump 1
D/I 4	Thermal compressor 2	Thermal compressor 2
D/I 5	High pressure C1	High pressure C1
D/I 6	Low pressure C1	Low pressure C1
D/I 7	Thermal compressor 1	Thermal compressor 1
D/I 8	Heater fan C1	Heater fan C1
D/I 9	Summer/Winter	Summer/Winter
<b>Expansion Digital Inputs</b>		
D/I 1	Not present	Thermal compressor 5
D/I 2	Not present	High pressure C2
D/I 3	Not present	Low pressure C2
D/I 4	Not present	Thermal compressor 4
<b>Controller Analog Outputs</b>		
A/O 1	Ventilation C1 (PWM)	Ventilation C1 (PWM)
A/O 2	Not used	Ventilation C2 (PWM)
<b>Expansion Analog Outputs</b>		
A/O	Not present	Not used
<b>Controller Digital Outputs</b>		
D/O 1	Heat sink pump 1	Heat sink pump 1
D/O 2	Compressor 1	Compressor 1
D/O 3	Compressor 2	Compressor 2
D/O 4	Heat sink anti-frost resistance C1	Heat sink anti-frost resistance C1
D/O 5	Ventilation C1 (Enabling)	Ventilation C1 (Enabling)
D/O 6	Solenoid valve C1	Solenoid valve C1
D/O 7	Reversing valve C1	Reversing valve C1
<b>Expansion Digital Outputs</b>		
D/O 1	Not present	Compressor 4
D/O 2	Not present	Compressor 5
D/O 3	Not present	Ventilation C2 (Enabling)
D/O 4	Not present	Reversing valve C2
D/O 5	Not present	Solenoid valve C2

**CAUTION!** When the machine type is changed, it is necessary to switch OFF and then back ON the plant, to enable the unit to reconfigure itself correctly; to allow the card to assign all affected parameters, it is advisable to wait for a few seconds (3 seconds are more than ample time), before interrupting the unit's power supply.

### 8.3 Configuration of Circuits

In case of dual refrigerant circuits ( $PG01=2$ ), some basic features need to be defined:

1. Single or dual condensing units (parameter  $PG11$ )

This configuration has an effect:

- On condenser control, in case of a single fan, the control is based on the highest value of the condenser pressure/temperature.
- On heat pump units during defrost control, in case of a single fan it is not possible to carry out separate defrosting of each circuit.

2. In case of ZERO ENERGY BAND control ( $PC11=1$ ), compressor control is based on the average value of the two evaporate leaving temperature sensors. Via parameter  $PC02$ , it is possible to select the distribution of the chilling steps required by controlling the two compressor circuits;

- a.  $PC02=0$  the 2 circuits are balanced
- b.  $PC02=1$  saturates the steps of one circuit, before requesting any of the other.

3. In case no compressor is running, the 2 evaporate temperature sensors will decide which compressor circuit must be started first

- a. In case of  $mode=Cool$  (*chiller*), the circuit with the highest evaporate leaving temperature will start first
- b. In case of  $mode=Heat$  (*heat pump*), the circuit with the lowest evaporate leaving temperature will start first

4. Evaporating single or separated ( $PG12$ )

In case of evaporating single ( $PG12=1$ ), the management, the resistors and the alarm of anti-frost are single. Control is carried out by reading the highest of the temperature value from water leaving temperature sensor.

With evaporating single the activated resistors and anti-frost alarm are always that related to Circuit # 1, Circuit # 2 is not controlled.

### 8.4 Operating Mode Control

The operating mode can take on the following values:

"MOdE" parameter	Operating mode	Description
0=Cool	Chiller	Summer operation
1=Heat	Heat pump (*)	Winter operation

(\*) Heat pump operation is only possible if the machine has been configured as *chiller* + heat pump (parameter PG00=2,4).

If the machine has only been configured as chiller (*parameter PG00=1,3*), the *MOdE* parameter is no longer modifiable, thus the operating mode is fixed at 0 (i.e. **Cool**).

There are several procedures which enable configuration of the machine's operating mode:

Via the *MOdE* parameter, accessible from the User menu.

Setting - Go to the parameter, then, pressing the ENTER key, modify the value using the UP and DOWN keys. Confirm by pressing ENTER once more: the corresponding icon will confirm that modification has been successful.

Via the command **Summer/winter from digital input** (this function is enabled by parameters *PH08*).

Setting - With open contact, the unit is set for winter operation, whereas with closed contact it is set for summer operation. Commutation of the digital input switches the unit OFF, changes its operating mode, and then switches the unit back ON.

Using a **supervisory protocol** (this function is enabled via parameter *PH10*).

Setting - Send from protocol the operating-mode change command: the corresponding operating mode icon will confirm that modification has been successful.

Via the automatic **Change-over** function (this function is enabled via parameter *PH06*).

Setting - When the outdoor air temperature value exceeds the *Summer Commutation Set Point PC61*, the unit commutates to summer operating mode. Conversely, when the outdoor air temperature value falls below the *Winter Commutation Set Point PC62*, the unit commutates to winter operating mode.

In order to enable this function, the outdoor air temperature sensor must be enabled.

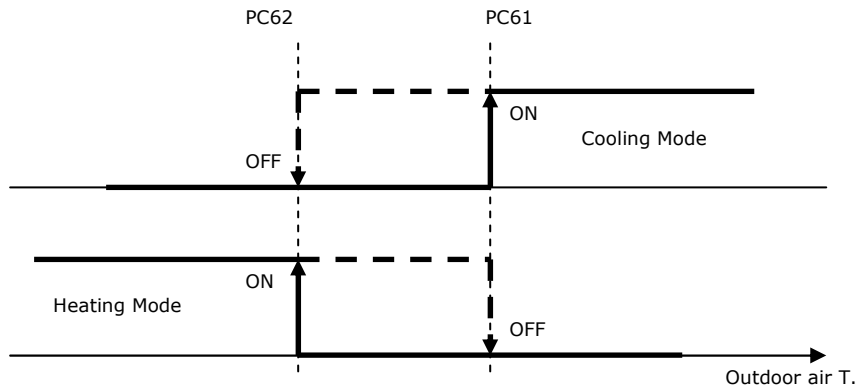

**WARNING** - Operating mode change-over can also happen while the machine is ON: in this case, the machine switches itself OFF - complying with all its timings - then commutates, and thereafter switches itself back ON automatically.

**Note:** During commutation, high and low-temperature controls are enabled.

**Note:** Commutation is disabled during defrosting cycles.

## 8.5 Setting the RTC

When the power supply is disconnected from the controller for a few days, the RTC (Real Time Clock) system clock loses its time. When the controller power is up again, it requires to reset the RTC alarm (enabled by PA30=1) and setting the correct date and time. In this case, upon machine startup the "Setting RTC" page will appear to set the time.

Once the clock has been configured, press **OK** to update the RTC time. The main application page will be shown. Pressing **OK** to confirm the reset of the clock alarm (*ERTC*) at which point the conditions of the alarm has been restored.

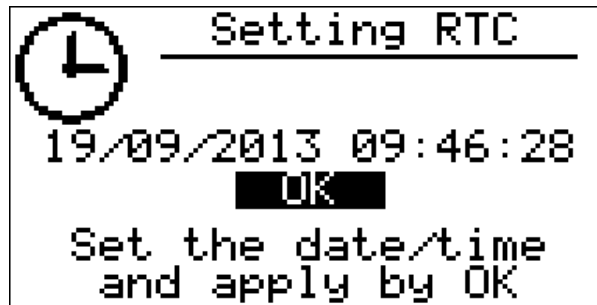

If use the LED display type, set the date-time and then press right button to show the page for apply the modification. Press enter on the "Set rtc" text to confirm the date-time.

In case the alarm doesn't disappear: remove and reconnect the power of the controller and then manually reset the alarm.

**Note.** This function is enabled only if the parameter *PG04=1*, that is, if the system clock is enabled.

## 8.6 Compressor Control

The control of water temperature (air-to-water or water-to-water machines) is carried out via the control of mechanical components, i.e. compressors and/or fans. Two types of control are provided: lateral-band control on entering chilled water temperature and zero energy band control on leaving chilled water temperature.

### 8.6.1 Lateral-band (LB) control

Lateral-band control is a proportional control function. The chilled water temperature is controlled by switching on or off compressors. The following figure illustrates the behavior of lateral band control (Set point, Set point + Proportional band) in the case of summer operation (chiller). Depending on the chilled water entering temperature, the numbers of compressors (steps) are increased or decreased. In this control mode, the entire band is shifted above the set point.

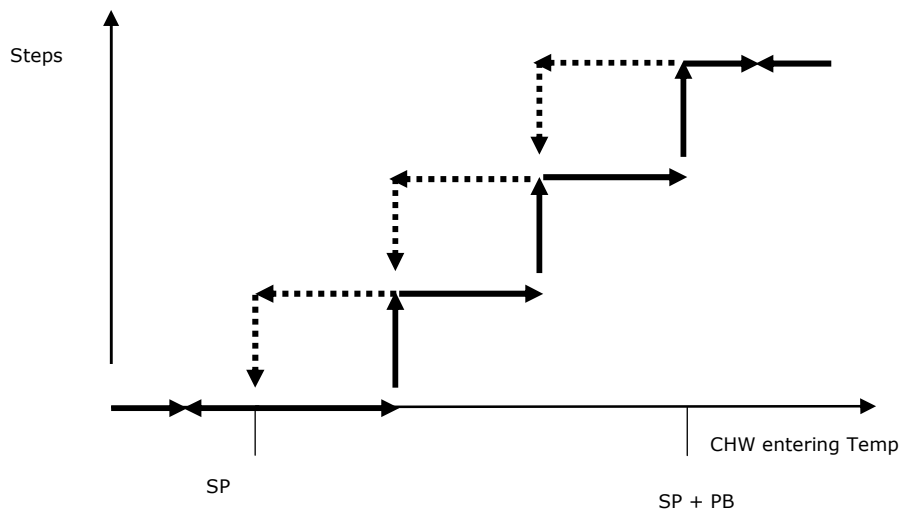

- Mode = Operating mode (0 = Summer)
- SPC1 = LB summer set point
- PC11 = Control type (0 = Lateral band)
- PC12 = Proportional band
- PC21 = Chiller set point lower limit
- PC22 = Chiller set point upper limit

Conversely, in winter operating mode (heat pump), the entire band is shifted below the set point:

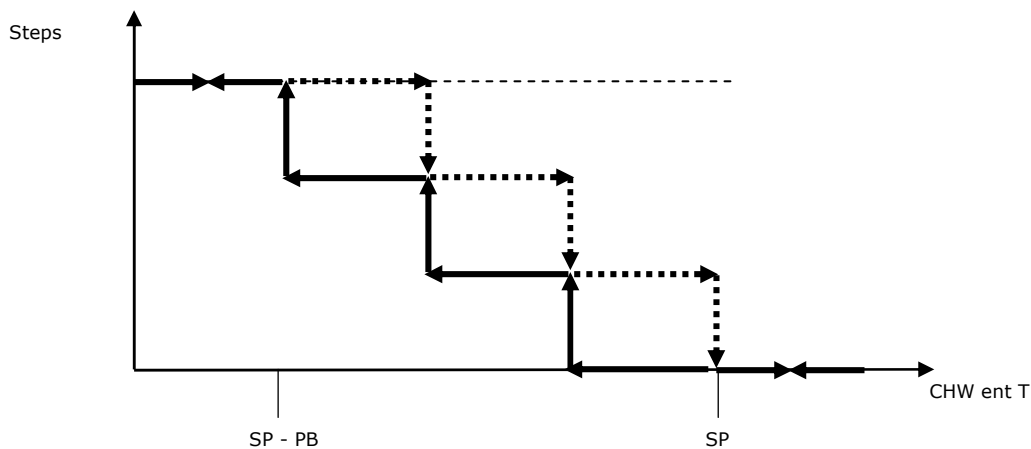

- Mode = Operating mode (1 = Winter)
- SPH1 = LB winter set point
- PC11 = Control type (0 = Lateral band)



- PC12 = Proportional band
- PC23 = Heat pump set point lower limit
- PC24 = Heat pump set point upper limit

**8.6.2 Zero energy band (ZEB) control**

This control type requires the definition of a zero energy band (ZEB) around the set point. Compressors will not be switched on or off within the zero energy band.

If the CHW leaving temperature is outside the zero energy band, the compressors are activated/de-activated, in order to bring the CHW leaving temperature value back into the zero energy band.

The requests for switching ON/OFF for the various power steps provided by compressors in summer operating mode (chiller) will follow this logic:

- Switching ON: when the CHW leaving temperature exceeds the zero energy band.
- Switching OFF: when the CHW leaving temperature falls below the zero energy band.

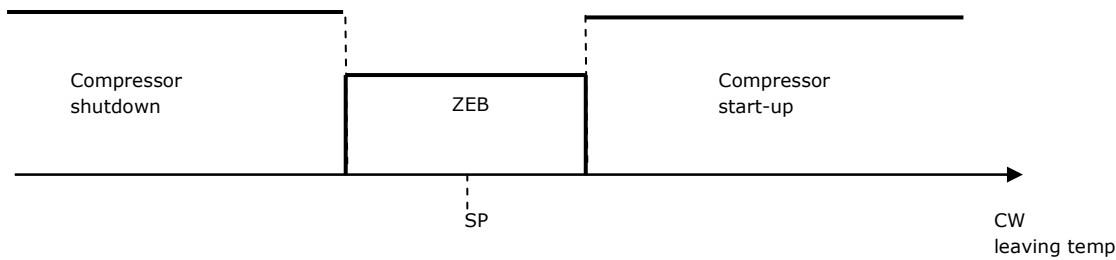

- Mode = Operating mode (0 = Summer)
- SPC1 = NZ summer set point
- PC11 = Control type (1 = Zero energy band)
- PC14 = Zero energy band
- PC17 = Extra time for out-of-zone request
- PC21 = Chiller set point lower limit
- PC22 = Chiller set point upper limit

The requests for switching ON/OFF for the various power steps provided by compressors in winter operating mode (heat pump) will follow this logic:

- Switching ON: when the CHW leaving temperature falls below the zero energy band.
- Switching OFF: when the CHW leaving temperature exceeds the zero energy band.

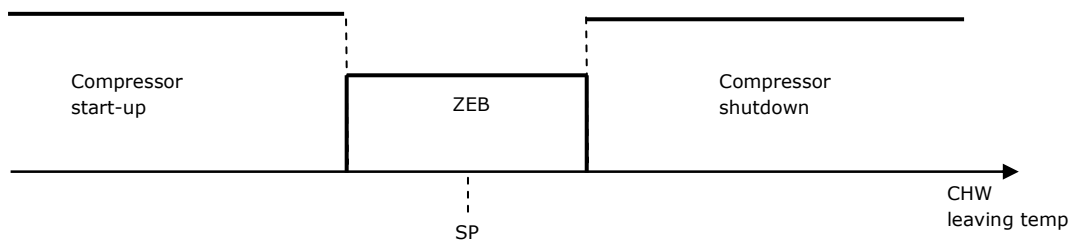

- Mode = Operating mode (1 = Winter)
- SPH1 = NZ winter set point
- PC11 = Control type (1 = Zero energy band)
- PC14 = Zero energy band
- PC17 = Extra time for out-of-zone request
- PC23 = Heat pump set point lower limit
- PC24 = Heat pump set point upper limit

### 8.6.3 Auto adaptive control

If the CHW leaving temperature still remains outside the zero energy band, even after the extra-time interval set in parameter PC17 has elapsed, the switching ON or OFF of a further power step will be requested.

The setting of parameter  $PC18 = 1$  activates an output-temperature auto-adaptive control function, in which the zero energy band is calculated in such a way as to take into account the dynamic properties of the plant and load variations. In particular, the zero energy band can vary taking into account compressor timings and the number of start-ups per hour. In this case, the value of parameter PC14 (zero energy band) only makes sense at unit start-up, whereas it will be recalculated – within the minimum PC15 limit and maximum PC16 limit – to “adapt” to an intermediate operating situation, as compared with the maximum number of hourly start-ups (parameter PC09).

PC09 = maximum number of hourly start-ups

PC14 = Zero energy band

PC15 = minimum limit

PC16 = maximum limit

PC17 = Extra time for out-of-zone request

PC18 = enable auto-adaptive control

**Note:** In the case of a twin-circuit system ( $PG01=2$ ), control is carried out on the average value of the two chilled water leaving-temperature sensors.

If one sensor fails, the control function is based on the other healthy sensor.

If both sensors fail, controlling is no longer possible. Parameter PC10 defines the number of compressors which will be activated in each circuit.

## 8.7 Compressor Management

The program is capable of managing up to a maximum of 3 compressors of the same power for each circuit, thus 6 compressors in total. Each compressor has a digital input for protection devices and a digital output for ON/OFF switching.

Compressors are controlled by lateral-band or zero energy band control (see previous chapter) with respect to the compressor timings.

### 8.7.1 Compressor status

The status of each compressor is visualized in the operator HMI. A compressor can take on the following statuses:

*Disabled:* The compressor has not been configured, the display shows “-”.

*On:* The status display shows “ON”.

*Waiting to switch ON:* The compressor is waiting for protection timings, before switching ON. The status display shows “WON”.

*Off:* The status display shows “OFF”.

*Waiting to switch OFF:* The compressor is waiting for protection timings, before switching OFF. The status display shows “WOFF”.

*Alarm:* The compressor is in alarm status. The status display shows “ALARM”.

*Manual:* The compressor is in manual operating mode. The status display shows “MANUAL”.

In the maintenance operator menu, via parameters  $PM01$ ,  $PM02$ ,  $PM03$  and  $PM04$ , it is possible to read the number of operating hours of the corresponding compressors. To zero these hours, it is sufficient to enter a “0” value using the ENTER key.

### 8.7.2 Rotation of compressors

Rotation of compressors is a procedure which enables balancing – as far as possible – of the number of operating hours and start-ups of each compressor.

In case of twin circuits, rotation must balance the operation hours of both circuits. Rotation does not affect any compressors in alarm status or manual operation mode, and is capable of dynamically switching ON other compressors, in case one or more of them should be in alarm status.

Via parameter  $PC01$ , the program is capable of managing 4 types of rotation: FIFO, LIFO, FIFO + number of hours, LIFO + number of hours.

#### 1. FIFO

This method follows the “*First In First Out*” logic, i.e. the first compressor to be switched on will have to be the first to be switched OFF again. This operating logic could initially lead to a great difference in the number of operating hours between the various compressors, but, after the initial phase, the hours should more or less equalize.

This type of rotation has a peculiarity in cases where not all configured compressors within the plant are switched ON; indeed, if for example the first compressor is switched ON and then OFF again, the next compressor to be switched ON will be the second one. The

last compressor to be switched OFF is stored in memory, then the next compressor in the sequence is switched ON, so as to avoid always using the same compressor, thus exploiting in a better manner all configured elements.

## 2. LIFO

This method follows the "Last In First Out" logic, i.e. the last compressor to be switched ON will be the first to be switched OFF.

## 3. FIFO + number of operating hours

This type of rotation favors a comparison of the number of operating hours of the various compressors. At switching ON, the compressor with the least number of operating hours will be privileged, whereas at switching OFF priority will be given to the compressor with the greatest number of hours.

In case of having to choose between compressors with the same number of operating hours, a FIFO rotation is triggered, so as to guarantee a rotation anyway, even in the presence of the same number of hours (see the previous FIFO case).

## 4. LIFO + number of operating hours

This type of rotation favors a comparison of the number of operating hours of the various compressors. At switching ON, the compressor with the least number of operating hours will be privileged, whereas at switching OFF priority will be given to the compressor with the greatest number of hours.

In case there needs to be a choice between compressors having the same number of operating hours, a classic LIFO rotation is triggered.

On twin-circuit machines, it is possible to decide – based on parameter *PC02* – how the steps requested by thermal control are to be shared between the two circuits:

**PC02 = 0. Circuit balancing:** the system requests alternatively a step per circuit, so as to balance loads between the two circuits, provided no alarms have been activated.

**PC02 = 1. Circuit saturation:** the system requests all available steps from the first circuit, and then all those available from the second circuit, so as to always have one circuit under full load, provided no alarms have been activated.

### 8.7.3 Pump-down switch-OFF procedure

On machines with power above a certain limit and where there is a substantial amount of refrigerant, the pump-down procedure is necessary to partially empty the evaporator of excess refrigerant. Therefore, the solenoid valve situated upstream from the related evaporator is controlled in such a way that the compressor remains ON for the time interval *Compressor switch-OFF delay in pump-down* (parameter *PC42*). At compressor start-up, the solenoid valve is opened at the precise same instant. In order to enable this function, the following parameters must be set:

PC41 = 1: Function enable

PC42: Pump-down time

**Note:** In case of alarm, the system must ignore the compressor switch-OFF delay.

### 8.7.4 Relative-threshold pump-down

If low-pressure transducers are available, it is possible to carry out the pump-down procedure leaving the compressor ON only for the time necessary to empty a correct part of refrigerant. At the end of the request by the last compressor to be ON from the affected evaporator, the evaporation pressure value is stored, the fluid solenoid valve is disabled, and, once the evaporation pressure value has fallen by the *Pump-down pressure differential PC43*, the compressor is switched OFF.

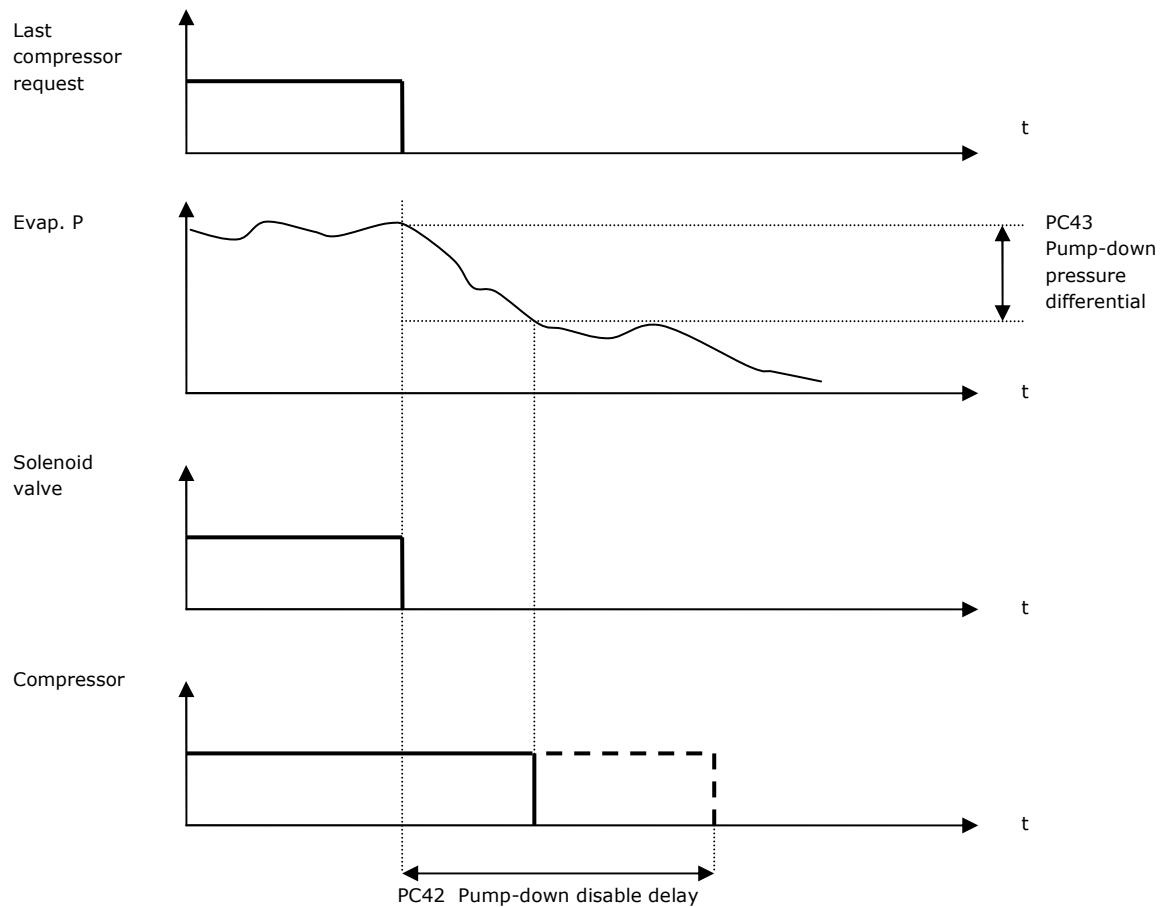

Anyway, there is always the Compressor switch-OFF delay in pump-down, should the switch-OFF pressure threshold not be reached, or should evaporation sensors be faulty.

In order to enable this function, the following parameters must be set:

PC41 = 2: Function enable

PC42: Pump-down time

PC43: Pump-down differential

**Note:** In case of alarm, the system must ignore the compressor shutdown delay.

### 8.7.5 Protection timings

The purpose of these timings is that of protecting mechanical units from the various start-up stresses to which they are subjected.

*PC04 = Compressor minimum ON time.* Once it has been activated, a compressor must remain ON for this time interval, before it can be switched OFF again.

*PC05 = Compressor minimum OFF time.* This is the minimum time interval that must elapse from the last switching-OFF, before the compressor can be switched back ON again.

*PC06 = Minimum time between switching-ON of the same compressor.* It determines the minimum time which must elapse between two switching-ON of the same compressor.

*PC07 = Minimum time between switching-ON of different compressors.* It determines the minimum time which must elapse between the switching-ON of a compressor and that of the next one.

*PC08 = Minimum time between switching-OFF of different compressors.* It determines the minimum time which must elapse between the switching-OFF of a compressor and that of the next one.

*PC09 = Maximum number of compressor start-ups within one hour.* This determines the maximum number of switching-ON within the time span of one hour: should this limit be reached, the regulator will wait until conditions are present, before switching that compressor ON again.

#### Neutral-zone timings

These parameters are used to time the request for switching ON/OFF the various compressors.

PC17 = Extra time for ON/OFF switching request

#### 8.7.6 Thermal protection inputs

The program provides for the management of a compressor thermal safety switch input for each compressor. For this input, it is possible to set, via parameters, the type of reset (manual or automatic), as well as the triggering delay.

### 8.8 Condenser control

Condenser control controls the condensing pressure by modulating the air flow via an analogue output (inverter or phase-cut), or with a single stage fan for each circuit. Condenser control is set by parameter PF01:

- PF01 = 0: Single stage control
- PF01 = 1: Modulating control.

If parameter *PF02* is set to 0, control will be independent of temperature control; otherwise, fans will be activated only if the controller requests the switching ON of at least one compressor.

The parameter PF03 sets whether or not fans must switch OFF during defrosting cycles, if PF03 is set to 1 fans will stop during defrost.

If parameter PF09 is set to 1, fans are forced in case of condensing sensor alarm with single stage Control. If the control is Modulated the parameter PF10 set the value to force.

#### 8.8.1 Modulating fan control

Thanks to the continuous control of fans, a proportional (or proportional/integral) control of condensation is performed, via an inverter (output A03, 0-10 V type), or via a phase-cut module (pulsed output A01).

Fan speed control provides for a minimum speed value, to manage start-ups in such a way as to avoid operating fan motors at an excessively low rpm rate. In addition, it is possible to set a *Speed-up time PF28* at start-up, during which the fan will reach maximum speed.

The possibility is provided for, of maintaining the fans at minimum speed, even below the set point value. Should pressure decrease further below the set point of a given threshold, fan switching OFF is forced.

There is, in addition, a high-speed value beyond which velocity remains constant. If maximum forcing has been enabled, should pressure increases further, exceeding a given threshold, fan speed will be forced to 100%.

The following figure illustrates the behavior of continuous control in the case of summer operation (chiller). In this particular control, the proportional band is completely shifted above the set point.

**Note:** Both outputs A01 and A03 will have the same control signal. Output A01 has a PWM output type and can be used with the single phase cutting module EVFan. The output A03 has a 0..10V output type and can be used with Schneider Electric ATV drive..

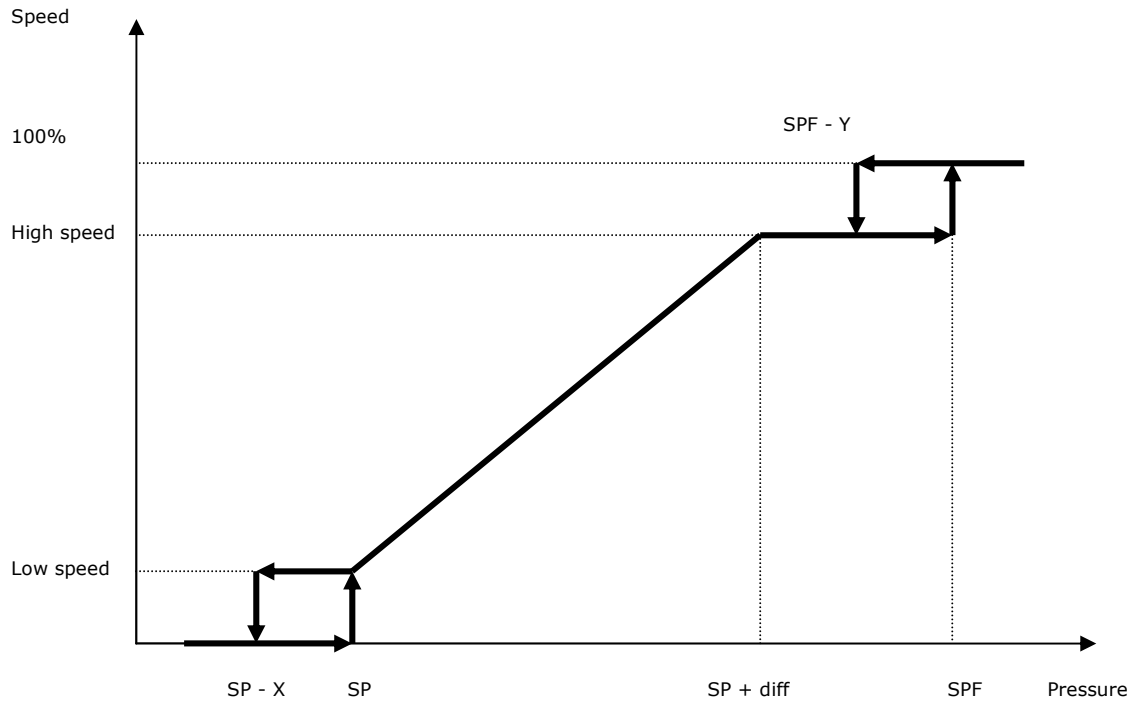

M

- Mode = Operating mode (0 = Summer)
- PF11 = Summer condensation control set point (SP)
- PF12 = Summer condensation control differential
- PF13 = Maximum speed forcing enable
- PF14 = Summer maximum speed forcing set point (SPF)
- PF15 = Summer maximum speed forcing differential (Y)
- PF16 = Integral time PI regulator
- PF27 = Inverter forcing minimum value
- PF28 = Speed-up time
- PF31 = Fan low-speed limit
- PF32 = Fan high-speed limit
- PF33 = Fan control enable below set point
- PF34 = Fan switching OFF differential below set point (X)

The following figure illustrates the behavior of continuous control in the case of winter operation (heat pump). In this particular control, the proportional band is completely shifted below the set point.

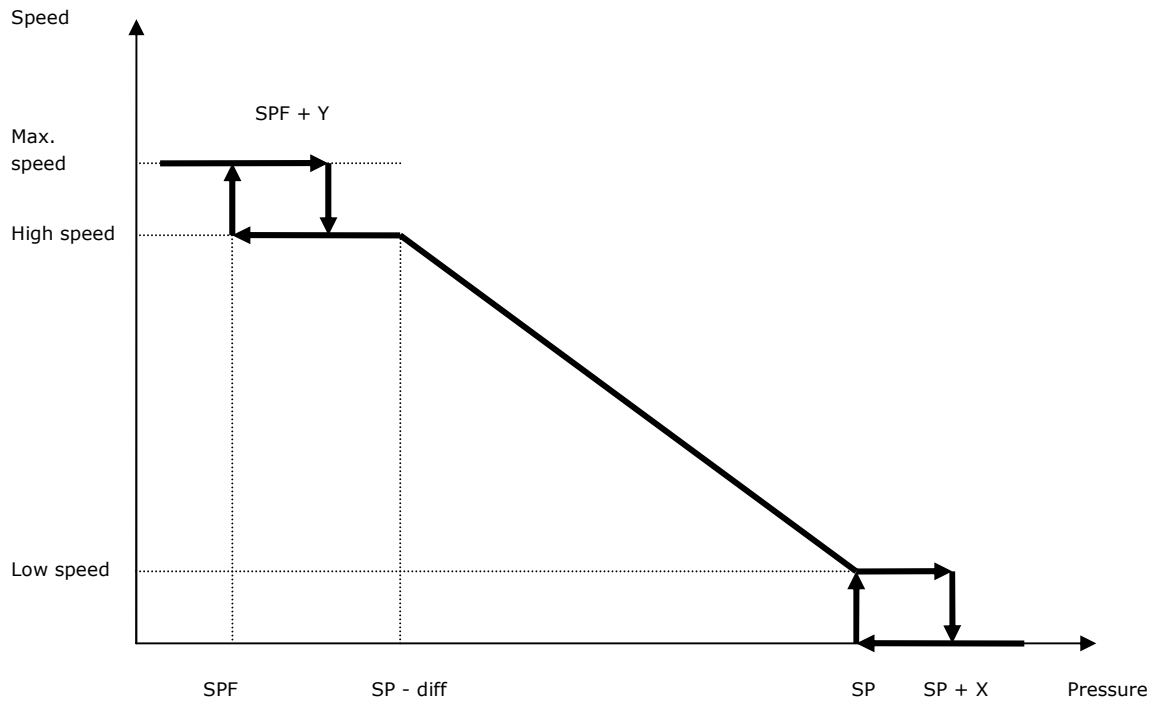

- Mode = Operating mode (1 = Winter)
- PF21 = Winter condensation control set point (SP)
- PF22 = Winter condensation control differential
- PF13 = Maximum speed forcing enable
- PF24 = Winter maximum speed forcing set point (SPF)
- PF25 = Winter maximum speed forcing differential (Y)
- PF26 = Integral time PI regulator
- PF27 = Inverter forcing minimum value
- PF28 = Speed-up time
- PF31 = Fan low-speed limit
- PF32 = Fan high-speed limit
- PF33 = Fan control enable above set point
- PF34 = Fan switching OFF differential above set point (X)

**Note.** With parameters PF41, PF42, PF43, PF45, PF46 and PF47 it is possible to linearize the analog output.

**8.8.2 Single stage fan control**

Manage a single stage control of condenser fans by a digital output for every fan.

The condenser fan is switched on when the condenser pressure exceeds the condenser setpoint + condenser pressure differential. The condenser fan is switched off when the condenser pressure falls below the condenser setpoint, see also next picture.

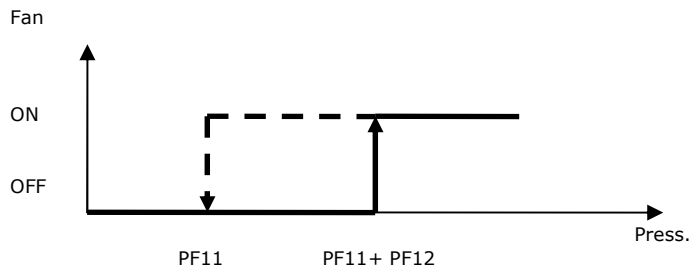

PF11 = Summer condensation control set point

PF12 = Summer condensation control differential

Mode = Operating mode (0 = Summer)

PF11 = Summer condenser control set point (SP)

PF12 = Summer condenser control differential

The condenser fan is switched on when the condenser pressure falls below the condenser setpoint - condenser pressure differential. The condenser fan is switched off when the condenser pressure exceeds the condenser setpoint.

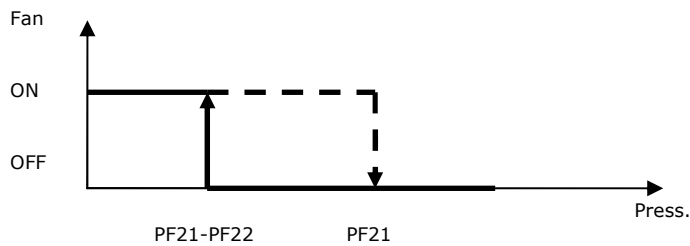

PF21 = Winter condensation control set point

PF22 = Winter condensation control differential

Mode = Operating mode (1 = Winter)

PF21 = Winter condenser control set point (SP)

PF22 = Winter condenser control differential

**8.8.3 Condenser valve control**

On water-to-water machines, during summer operation, the water feeding the condensing circuit is controlled according to condensing pressure, via a valve (this can be a two-way solenoid or motor-operated pressure-switch valve, modulating with a 0-10 V control-generated signal). Condenser control is performed in similar fashion to fan speed control. The condenser valve control is a proportional integral control type.

In order to utilize only a proportional control you need to only set the integral time to zero ( $PF16=0, PF26=0$ ). Setting an integral time greater than zero will provide a more precise control, the integral part is tasked with bringing the output up to speed reducing the error introduced by the sole proportional component (by default the integral component is disabled).

**8.8.4 Single condenser**

On twin-circuit machines, it is possible to choose to use only one circuit to manage condensation. In order to enable this function, it is necessary to set  $PG11=1$ . Condensing is performed by the fan in Circuit # 1, using the highest of the condensing pressure/temperature values acquired from the respective transducers.

The activated analogue/digital output is always the one related to Circuit # 1.



## 8.9 Fan Management

The program is capable of managing up to 2 fans, i.e. one for each circuit. It is possible to associate to each fan a safety digital input and a digital output for ON/OFF switching.

### 8.9.1 Fan status

Each fan has an associated operating status in the status template of the main menu. A fan can take on the following statuses:

*Disabled*: The fan has not been configured, the status display shows "-".

*On*: The status display shows "ON".

*Waiting to switch ON*: The fan is waiting for protection timings, before switching ON. The status display shows "WON".

*Off*: The status display shows "OFF".

*Waiting to switch OFF*: The fan is waiting for protection timings, before switching OFF. The status display shows "WOFF".

*Alarm*: The fan is in alarm status. The status displays shows "ALARM".

*Manual*: The fan is in manual operating mode. The status display shows "MANUAL".

In the Maintenance Operator menu, via parameters *PM41* and *PM42*, it is possible to read the number of operating hours of the two fans. To zero these hours when required, it is sufficient to enter a "0" value, using the ENTER key.

### 8.9.2 Fan timings

There now follows a list of all timings connected with the management of fans.

Protection Timings

The purpose of these delays is that of protecting fans from the various start-up stresses to which they are subjected and of avoiding simultaneous start-ups.

*PF07 = Minimum time between start-ups of different fans*. It determines the minimum time which must elapse between the start-up of a fan and that of the next one.

*PF08 = Minimum time between shutdowns of different fans*. It determines the minimum time which must elapse between the shutdown of a fan and that of the next one.

### 8.9.3 Thermal Protection Inputs

The program provides for the management of a single fan thermal protection for each of the fans configured within the application.

### 8.10 Circulating Pump Management

On AIR-TO-WATER or WATER-TO-WATER machines, 1 or 2 water-circulating pumps can be controlled, which are defined by the parameter *PG09*. The *Pump operation PP01* parameter defines how the pump will operate:

- PP01 = 0: Continuous operation
- PP01 = 1: Operation at thermostat's request
- PP01 = 2: Cyclic operation

In *continuous operation* the circulating pump is activated when the unit is switched ON and, after expiration of a time delay interval (parameter *PP04*), the compressors could be energized. When the unit is switched OFF the pump will be deactivated after a time delay interval (parameter *PP05*).

In *operation at thermostat's request*, the pump is operated as a result of a request for heat or cold. Upon such a request, first the pump output is activated and then – after delay *PP04* – the chilling/heating compressor is switched ON.

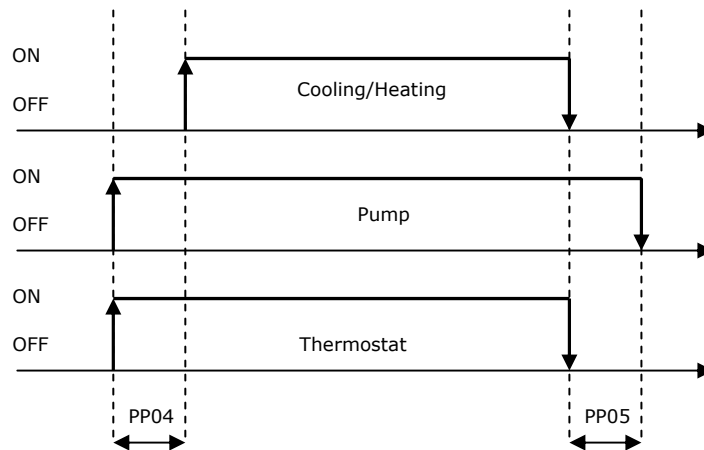

In similar fashion, upon a thermostat's switch-OFF request, the compressor switches OFF, whereas the pump remains ON for the duration of *PP05*.

In *cyclical operation*, the pump is controlled by the definition of start-up/shutdown times: if during the pump activation time the thermostat function triggers a chilling or heating request, the pump remains activated for the whole duration of this request, plus any delay interval between compressor shutdown and pump shutdown.

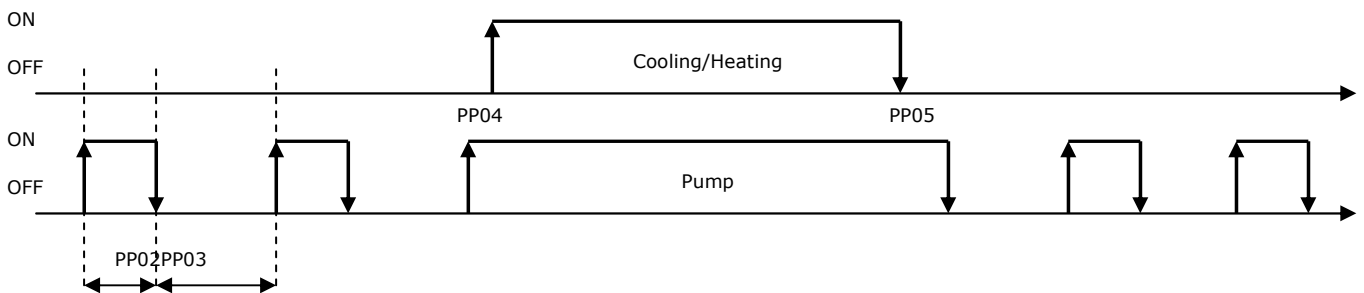

- PP02 = Pump ON cycle time.
- PP03 = Pump OFF cycle time.

Parameter *PP07* defines the pump's behavior during a defrosting cycle. After modification of *PP01* and *PP07*, it is necessary to power down the machine and then power it up again, to avoid the risk of malfunctions.

If two pumps have been configured (*PG09* = 2), both their operating hours must be equalized. Therefore, every *PP08* number of operating hours, shutdown is ordered for the active pump and start-up of the other pump.

In case of thermal alarm on one of the pumps, the control must activate the second pump. On the other hand, if both pumps are faulty, or if the only configured pump is faulty, the alarm stops the unit.

**8.10.1 Pump Status**

To each pump, an operating status is associated, which is visible from the associated LED or in the status template from the main menu. Each pump can take on the following statuses:

*Disabled:* The pump has not been configured, the status display shows “-”.

*On:* The status display shows “ON”.

*Off:* The status display shows “OFF”.

*Alarm:* The pump is in alarm status. The status display shows “ALARM”.

In the Maintenance Operator menu, via parameters *PM31* and *PM32*, it is possible to read the number of operating hours of the corresponding pumps. To zero these hours when required, it is sufficient to enter a “0” value, using the ENTER key.

**8.10.2 Flow Meter Management**

The flow meter is continuously monitored once the chiller is started and the *Flow meter start delay PA01* has been expired. If the contact indicates a lack of flow, the flow meter alarm is immediately triggered. The compressors will not be commanded when there is a flow meter alarm.

During normal operation, the flow meter is constantly monitored; if the contact signals a lack of flow for a period exceeding the value of parameter *Flow-meter alarm by-pass PA02*, the associated alarm is immediately triggered, and all active compressors are switched OFF.

If the alarm should persist for a time equal to the value of parameter *Pump operating time at low water level PP09*, the pump is also switched OFF, and the alarm becomes a manual reset. The pump is thus protected against potential operation without water. The pump is then restarted when the alarm is reset.

The flow-meter alarm is an automatic-reset alarm, unless it exceeds a given number of events within one hour (*Max. number of flow alarms with auto-reset PA03*), in which case it becomes a manual reset.

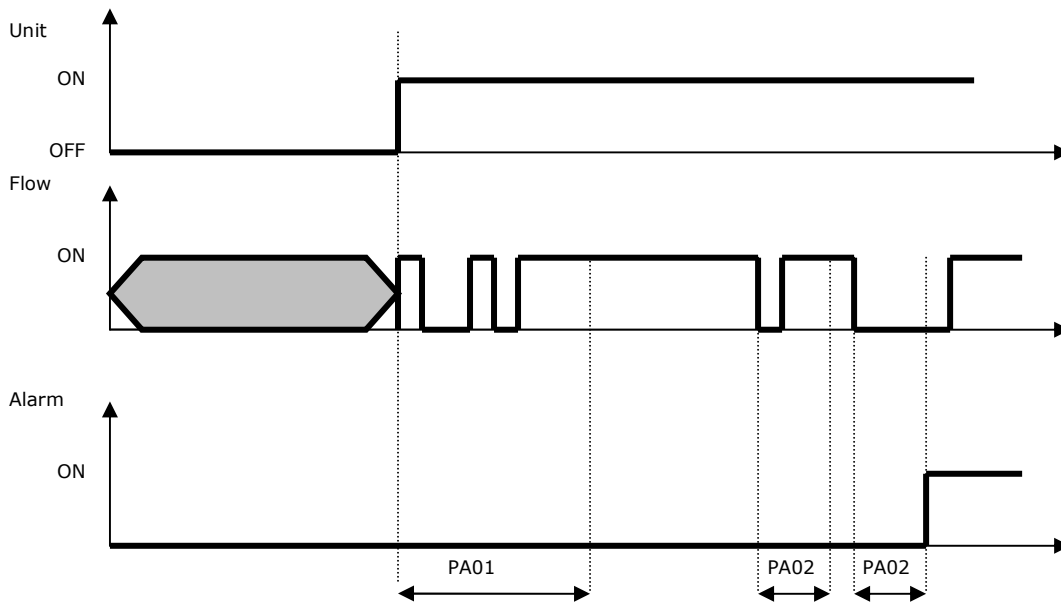

## 8.11 Circulating Source Pump Management

On WATER-TO-WATER machines, 1 or 2 source water-circulating pumps can be controlled, which are defined by the parameter *PG10*. The *Pump operation PP21* parameter defines how the pump will operate.

Regulations, status, flow meter controls and safeties for these devices are the same as of the circulating pumps described above.

## 8.12 Defrosting Management

This procedure is only activated in winter operating mode (heat pump), and when at least one compressor is switched ON. Defrosting is performed by intervening on the refrigerating-circuit inverter valve.

If evaporation pressure remains (even if not continuously), for a time interval equal to the value of parameter *Defrosting enable delay Pd03*, below the threshold of the *Defrosting start set point Pd01* and at least one compressor is in operation, the inverter valve is commutated and the defrosting cycle is started. During this phase, compressors are forced to maximum power, and the low-pressure alarm is bypassed.

Defrosting is interrupted for one of the following causes:

- When pressure reaches the End of defrosting set point Pd02;
- When the Defrosting duration max. time Pd04 has elapsed;
- When machine or circuit alarms have been triggered;
- When the unit has been switched OFF.

At the end of the defrosting cycle, the unit remains stationary for the whole duration of *Dripping time Pd06*.

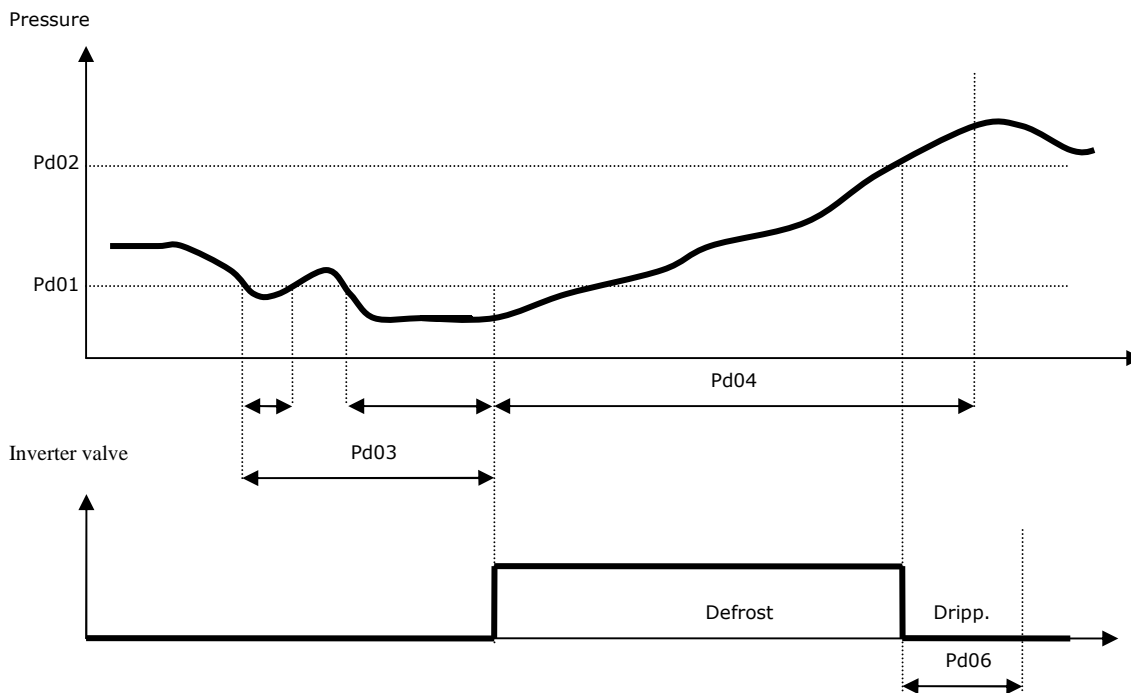

II

In order to avoid the immediate start of a defrosting cycle after all compressors have been stopped, a *Minimum circuit restart delay Pd07* is used, which guarantees at least a period of heat-pump operation, before entering the defrosting cycle.

**Note:** In the case of twin-circuit units, defrosting cannot be simultaneous; thus, if one circuit is defrosting, the other circuit cannot start a defrosting cycle until the defrosting circuit has completely finished its cycle.

### 8.12.1 Defrosting cycle compensation

With the decreasing of the outdoor air temperature, the water vapor content in the air (which causes the formation of frost on the evaporation battery, thus creating a need for defrosting) decreases, and it may therefore be advantageous to increase the defrosting-activation delay in relation to the decrease in the outdoor air temperature, to improve the overall efficiency of the system. If enabled by parameter *Pd20*, this function is activated at an *Outdoor air temperature set point for defrosting compensation start Pd21*, below which set point compensation starts, with the increment of the defrosting activation delay, up to a maximum value (*Maximum defrosting delay Pd23*) on reaching the *Outdoor air temperature set point for defrosting compensation stop Pd22*.

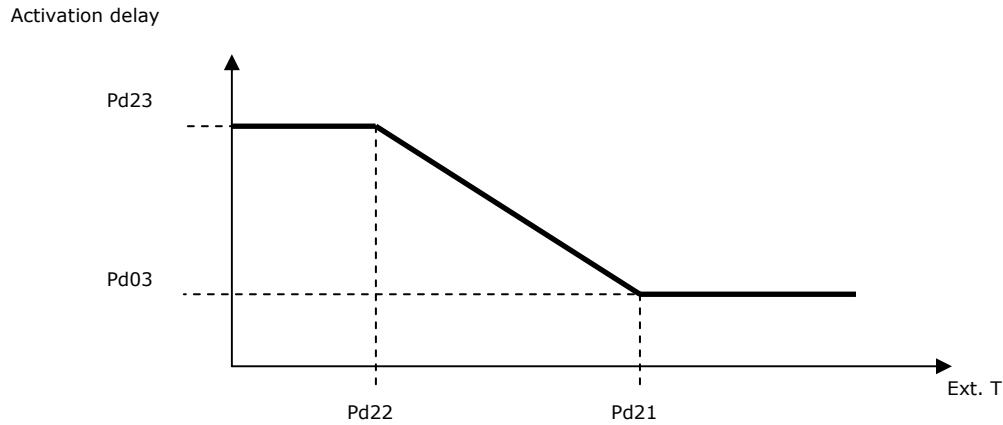

In order to enable this function, the outdoor air temperature sensor must be enabled.

### 8.13 Anti-freeze management / Chilling-support heating coils

On air-to-water or water-to-water machines, anti-frost control is active even when the machine is switched OFF.

Two thresholds are provided for, with their related differential: one is used to activate the heating coils and the other one to signal the alarm and stop compressors within the associated circuit.

If the anti-frost alarm should persist for the duration of the *Pump operation time at low temperature PP10*, the pump will be switched OFF until the next alarm reset.

In the case of anti-frost, in OFF status, only the heating coils are activated, whereas the alarm is not notified.

In order to enable the heating coils, in addition to setting the associated parameter (*Pr01=1*).

### 8.14 Single evaporation

On twin-circuit machines, it is possible to choose to use only one circuit to manage evaporation. In order to enable this function, it is necessary to set *PG12=1*. Evaporation is performed by anti-frost and resistors in Circuit # 1, using the highest of the evaporating temperature values acquired from the respective transducers.

The activated resistors and anti-frost alarm are always that related to Circuit # 1.

## 8.15 Free-Cooling Management

To obtain significant energy savings in the management of the system, the chiller has the possibility of using external air, when the air has favourable thermal characteristics, to take advantage of its energy content and to obtain "free cooling".

With free-cooling versions, a water coil is generally placed in front of the condenser coil (so that the air first flows past the water coil and then the condenser coil);

when the external air temperature is lower than that of the water (and it is therefore possible to cool the water at the expense of the external air), the water (or glycolmixture) that enters the machine is diverted onto the water coil by means of a three-way valve or by means of a specific pump before passing through the evaporator.

There is also the possibility of having a separate free-cooling circuit with a fan dedicated to this purpose ( $PG13=1,2$ ), allowing for better control of condensation while the compressors are on and, at the same time, for regulating the ventilation of free-cooling.

### 8.15.1 Enabling of Free-Cooling

The function of free-cooling (FC), if configured according to parameter  $PS01$ , is enabled when the  $\Delta T$  free-cooling (or the difference between the temperature of the inflowing water  $T_{InFC}$  and the external temperature that affects the exchanger of free-cooling  $T_e$ ) attains the setpoint value established ( $SetFC$ , parameter  $PS06$ ). In order to avoid possible fluctuations of the enabling status of free-cooling, it is also possible to set a differential ( $DiffFC$ , parameter  $PS07$ ).

1 = F.C. On  
0 = F.C. Off

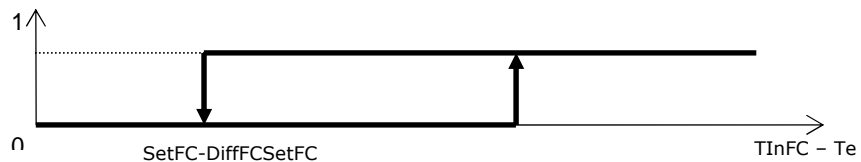

The condition of the step must last for at least a Minimum Enabling Time  $PS10$  (default 30 seconds) before enabling/disabling free-cooling.

In cases where the external probe is in error, free-cooling is disabled and the free-cooling control valve is deactivated.

In addition, the triggering of anti-frost resistance (and, even more so, the triggering of the corresponding alarm) will shut off the free-cooling mechanism.

Other system safety mechanisms—failure of the regulating probe, failure of the anti-frost control probe, evaporator flow meter alarm, circulation heat pump—cause the shutting down of the unit and thus the halting of the control of free-cooling.

### 8.15.2 Regulation of Free-Cooling

Enabling free-cooling allows you to activate control that is proportional to fan speed.

In cases where regulation of compressors, whether entering (lateral band) or leaving (neutral zone), the free-cooling setpoint always corresponds to the regulation of the heat sinks.

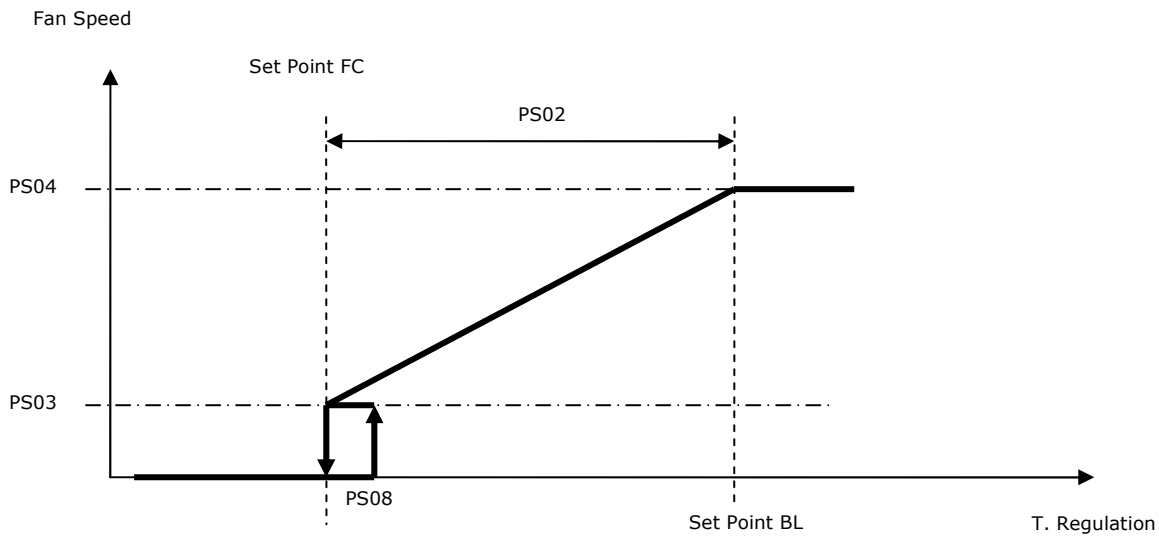

When the temperature reaches the FC Set Point and remains below for more than  $PS10$  seconds, it deactivates free-cooling; the step shown in the diagram, hysteresis  $PS08$  (default  $0.5^{\circ}\text{C}$ ), re-enables free-cooling and the ramp (if ON status is maintained for more than  $PS10$  seconds).

When free-cooling adjustment is on the steps, the call of the compressor steps is prevented; when the temperature reaches the upper limit of the proportional band and remains in this state for at least  $PS10$  seconds, it enables the compressor steps to be called to carry out the primary adjustment.

The fan can also be the ON/OFF type.

Depending on the configuration of parameters  $PG13$  and  $PG11$ , it is possible for free-cooling to act in different ways:

#### **PG13=0: SINGLE AIR CIRCUIT**

**In the case of single condensation ( $PG11=1$ )**, with active free-cooling the condenser fan will be controlled by the above-mentioned adjustment according to the entering temperature. If the compressors are turned on as a result of an increase in power, the controls will be switched from fan control to condenser control and will remain so until there is at least one active compressor in the circuit in question.

In this configuration, a single fan is used and is the one that refers to circuit 1. This fan will handle condensation and free-cooling (any free-cooling coils must be put in this position).

**In the case of separate condensation ( $PG11=0$ )**, a circuit normally regulates condensation, while the other condenser fan is controlled with the above-mentioned free-cooling adjustment.

In this configuration, the fan used exclusively for condensation is the circuit 2 fan. The circuit 1 fan will handle the condensation of the appropriate circuit and free-cooling if conditions are there (any free-cooling coils must be put in this position).

#### **PG13=1: SEPARATE AIR CIRCUIT**

**In the case of single condensation ( $PG11=1$ ), or in the case of separate condensation ( $PG11=0$ )** having two independent air circuits, there is no need to make a distinction; behaviour is identical. In this situation, it makes sense to use parameter  $PS05$  (enabling of free-cooling with compressors):

- $PS05 = 0$ . If at least one compressor is on, free-cooling is disabled, otherwise follow normal adjustment of the ramp.
- $PS05 = 1$ . If at least one compressor is on, the free-cooling ramp is forced to the maximum value (100% or another value set in parameter  $PS04$ ), otherwise follow normal adjustment of the ramp.

The condenser fans are independent from free-cooling.

To activate the fan associated with free-cooling, it is necessary to set the associated analog output as well.

**8.15.3 Free-Cooling control valve**

In a case where the valve is of the ON/OFF type, the activation control will follow the consensus step on Set Point FC, with *PS08* hysteresis, described earlier.

In order to enable the operation of the ON/OFF valve, it is necessary to set the associated digital output.

Alternatively, it is possible to have a 0-10V three-way modulating valve to allow the mixing of the water entering the evaporator for combined free-cooling action.

In this case, the valve is controlled proportionately from the consensus step until the threshold of maximum opening of the valve, corresponding to a percentage of the FC band (parameter *PS09*):

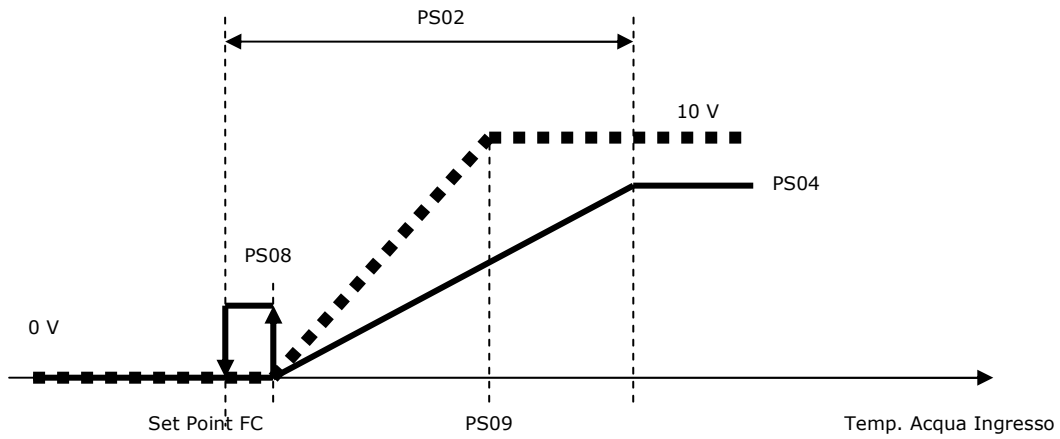

To enable the operation of the valve, it is necessary to set the associated analog output as well.



## 8.16 Temperature Alarm Control

### 8.16.1 Low and high temperature alarm management

According to operating mode, a check is carried out on the exchanger inlet temperature, triggering an alarm where appropriate.

- In winter operation (heat pump), if the temperature falls below a given threshold for a settable lapse of time, a "low temperature" alarm is generated: **AL01**.
- In summer operation (chiller), if the inlet temperature exceeds a given threshold for a settable lapse of time, a "high temperature" alarm is generated: **AL02**.

Via a configuration parameter, alarms can be set to be display-only alarms, or to stop the machine.

It is also possible to set a temperature-alarm inhibition delay from system start-up, so as to give the machine a chance to reach full power.

- PA05 = High-temperature alarm set point
- PA06 = Low-temperature alarm set point
- PA07 = Temperature alarm enable delay
- PA08 = Temperature alarm management mode (display-only / machine stop)
- PA09 = Temperature alarm differential
- PA10 = System start-up alarm inhibition time.

These alarms are only detected when the machine is switched ON.

### 8.16.2 Management of primary exchanger efficiency alarm

If this alarm **AL03** (and **AL13** for Circuit # 2) is enabled ( $PA25 = 1$ ), a check is made as to whether the difference between entering and leaving chilled water temperatures at the primary exchanger, is below a *Primary exchanger difference minimum threshold PA26* for a *By-pass time for primary exchanger efficiency alarm PA27*.

This alarm is not managed during defrosting, if sensors are in alarm status and this alarm is a manual-reset alarm.

This alarm is only detected when the machine is switched ON.

## 8.17 Pressure Alarm Control

### 8.17.1 Management of high-pressure pressure-switch alarm

Via a digital input connected to an external pressure switch, it is possible to monitor an excess of maximum condensing pressure. The *high-pressure alarm AL11* (and **AL12** for Circuit # 2) causes the immediate stopping of the refrigerating circuit, also shutting down any compressors which may be ON, and inhibiting the start-up of others.

This alarm is only detected when the machine is switched ON.

This is a manual-reset alarm.

### 8.17.2 Management of high-pressure transducer alarm

If condensing pressure exceeds a given threshold, a *high-pressure alarm AL31* (and **AL32** for Circuit # 2) is generated. The alarm causes the immediate stopping of the refrigerating circuit, also shutting down any compressors which may be ON, and inhibiting the start-up of others.

This alarm is only detected when the machine is switched ON.

This is a manual-reset alarm and it can be reset if in the meantime pressure has fallen below the maximum threshold of a given differential value.

- PA21 = High-pressure alarm set point
- PA22 = High-pressure alarm differential.

### 8.17.3 Management of low-pressure pressure-switch alarm (chiller mode)

Via a digital input connected to an external pressure switch, it is possible to monitor the presence of a minimum intake pressure in the refrigerating circuit. The *low-pressure alarm AL41* (and **AL42** for Circuit # 2) causes the immediate stopping of the refrigerating circuit, also shutting down any compressors which may be ON, and inhibiting the start-up of others.

At start-up of the first compressor, the alarm is delayed for a given interval, to enable the compressors to take the refrigerating circuit to full pressure.

The alarm is initially auto-resetting, unless it exceeds a given number of events within one hour ( $PA14$ ), in which case it becomes a manual-reset alarm.

- PA13 = Low-pressure alarm by-pass time
- PA14 = Maximum number of auto-reset low-pressure alarms

If, with the machine switched ON and in the presence of a request for chill from the controller, low pressure is detected, compressor start-up is inhibited and a *Start-up low-pressure alarm* **AL21** (and **AL22** for Circuit # 2) is displayed. The purpose of this condition is to inhibit compressor start-up in the absence of Freon® gas in the circuit (there could be a refrigerant leak from the piping system)

#### **8.17.4 Management of low-pressure transducer alarm (heat pump mode)**

If intake pressure falls below a given threshold, a *low-pressure alarm* **AL41** (and **AL42** for Circuit # 2) is generated. The alarm causes the immediate stopping of the refrigerating circuit, also shutting down any compressors which may be ON, and inhibiting the start-up of others.

At start-up of the first compressor, the alarm is delayed for a given interval, to enable the compressors to take the refrigerating circuit to full pressure.

The alarm is initially auto-resetting, unless it exceeds a given number of events within one hour (*PA14*), in which case it becomes a manual-reset alarm, which can be reset if in the meantime pressure has risen above the minimum threshold by a certain differential value.

PA11 = Low-pressure alarm set point

PA12 = Low-pressure alarm differential

PA13 = Low-pressure alarm by-pass time

PA14 = Maximum number of auto-reset low-pressure alarms

In the presence of *low temperatures of external air*, intake pressure could fall below the minimum- pressure threshold, thus inhibiting compressor start-up. In such a situation, it is possible to activate a control, which shifts the alarm-control threshold to a higher value for a given interval from start-up of the first compressor, leaving nevertheless in place all protection devices and pre-start checks.

PA16 = Low-pressure control enable at low outdoor air temperature

PA17 = Low-pressure alarm set point at low outdoor air temperature

PA18 = Low-pressure alarm differential at low outdoor air temperature

PA19 = Low-pressure alarm control duration at low outdoor air temperature

This control can only be enabled in heat-pump operating mode.

#### **8.17.5 Low start-up pressure alarm**

In a low-pressure condition (pressure switch or transducer-induced) and in the impossibility to activate any of the compressors at the request of the same, there is a *Low-pressure start-up alarm* **AL51** (and **AL52** for Circuit # 2). This is an auto-reset alarm, and thus should disappear, unless there is a leak of Freon® gas from the circuit.

At compressor shutdown following a low-pressure alarm, this alarm is delayed by a given interval *PA20*, to give the refrigerating circuit the chance to enable compressor start-up.

## 8.18 Time schedule

The real time clock allows the operator to define a weekly schedule for the unit.

Two different daily schedules can be defined. Each daily schedule can have 2 zones with separate heating and cooling offset values.

Each day of the week can be assigned to daily schedule 1, daily schedule 2 or can be identified as none working day.

The parameters referred to this function are the following:

PARAMETERS	FUNCTION
PT01	Working day 1 enable zone 1
PT02	Working day 1 zone 1 start time
PT03	Working day 1 zone 1 stop time
PT04	Working day 1 zone 1 cooling offset
PT05	Working day 1 zone 1 heating offset
PT06	Working day 1 enable zone 2
PT07	Working day 1 zone 2 start time
PT08	Working day 1 zone 2 stop time
PT09	Working day 1 zone 2 cooling offset
PT10	Working day 1 zone 2 heating offset
PT11	Working day 2 enable zone 1
PT12	Working day 2 zone 1 start time
PT13	Working day 2 zone 1 stop time
PT14	working day 2 zone 1 cooling offset
PT15	working day 2 zone 1 heating offset
PT16	working day 2 enable zone 2
PT17	working day 2 zone 2 start time
PT18	working day 2 zone 2 stop time
PT19	working day 2 zone 2 cooling offset
PT20	working day 2 zone 2 heating offset
PT21	Monday schedule
PT22	Tuesday schedule
PT23	Wednesday schedule
PT24	Thursday schedule
PT25	Friday schedule
PT26	Saturday schedule
PT27	Sunday schedule
PH16	Enable start-up/shutdown of the machine by the schedule

## 8.19 Miscellaneous Management

### 8.19.1 Set point variation by schedule timer

Via parameter *PH28* it is possible to adjust the setpoint by the schedule timer (set relative parameters of scheduler). Actual control setpoint depends by the working day and relative offset.

### 8.19.2 Dynamic set point

Via parameter *Dynamic set point enable PH27*, it is possible to perform compensation of the dynamic set point on outdoor air temperature. In this case, the control set point will take on a value between the standard set point (equivalent to the *External-temperature initial threshold*) and the set point **plus** a *Dynamic offset* (equivalent to the *External-temperature final threshold*), both for chiller and heat pump operation. Between the two compensation points, movement is linear, and the curve takes on a different meaning, according to the offset sign.

With offsets of less than zero value, behavior is as follows:

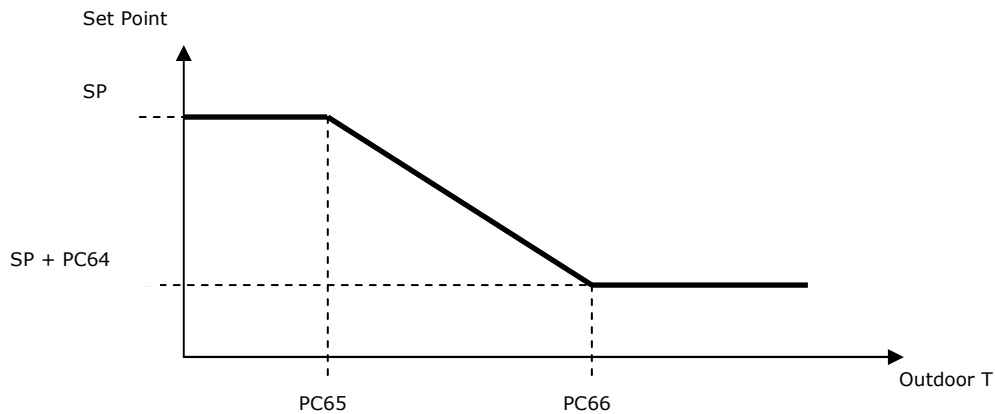

The parameters referred to this function are the following:

- PC64 = Maximum dynamic offset for summer operation (chiller)
- PC65 = Compensation start temperature for dynamic summer set point
- PC66 = Compensation stop temperature for dynamic summer set point.

With offsets greater than zero, behavior is as follows:

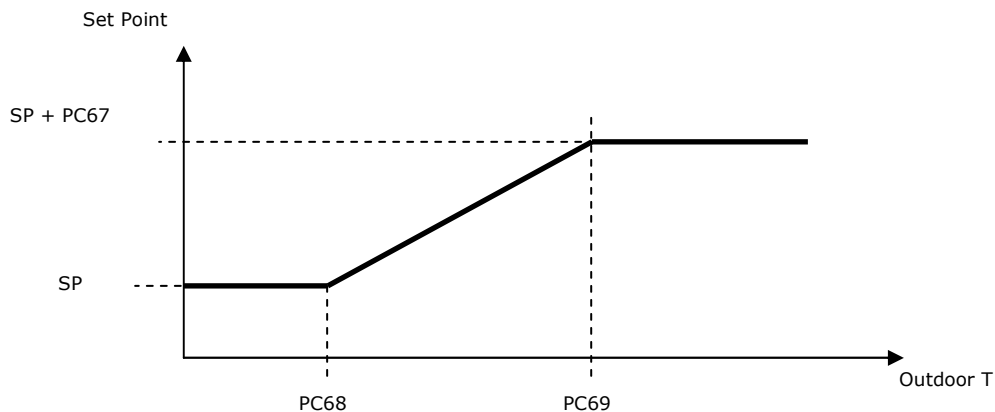

The parameters referred to this function are the following:

- PC67 = Maximum dynamic offset for winter operation (heat pump)
- PC68 = Compensation-start temperature for dynamic winter set point
- PC69 = Compensation- stop temperature for dynamic winter set point.

**8.19.3 Forced shutdown**

This function enables the forced shutdown of all compressors, when CHW leaving temperature falls below the *Summer forced-shutdown set point* (in the case of chiller operation), or exceeds the *Winter forced-shutdown set point* (in the case of heat-pump operation). Compressors can only be restarted when the temperature crosses the set point once again.

- PC35 = Forced-shutdown enable
- PC36 = Summer forced-shutdown set point
- PC37 = Winter forced-shutdown set point.

**8.19.4 High-pressure reduction at high temperatures (chiller)**

This control makes it possible for the refrigerating circuit to operate even at high outside air temperatures. The change of the high-pressure alarm is reduced by reduction of the circuit's active power.

- PC45 = Pressure reduction enable at high temperatures
- PC46 = Pressure reduction set point at high temperatures
- PC47 = Pressure- reduction differential at high temperatures
- PC48 = High external air temperature threshold
- PC49 = Min. time for maintaining pressure reduction.

According to the number of configured compressors, the power-limiting percentage is calculated on the basis of this parameter:

- PC31 = Power limiting for summer operation

In order to enable this control, the outdoor air temperature sensor must be enabled.

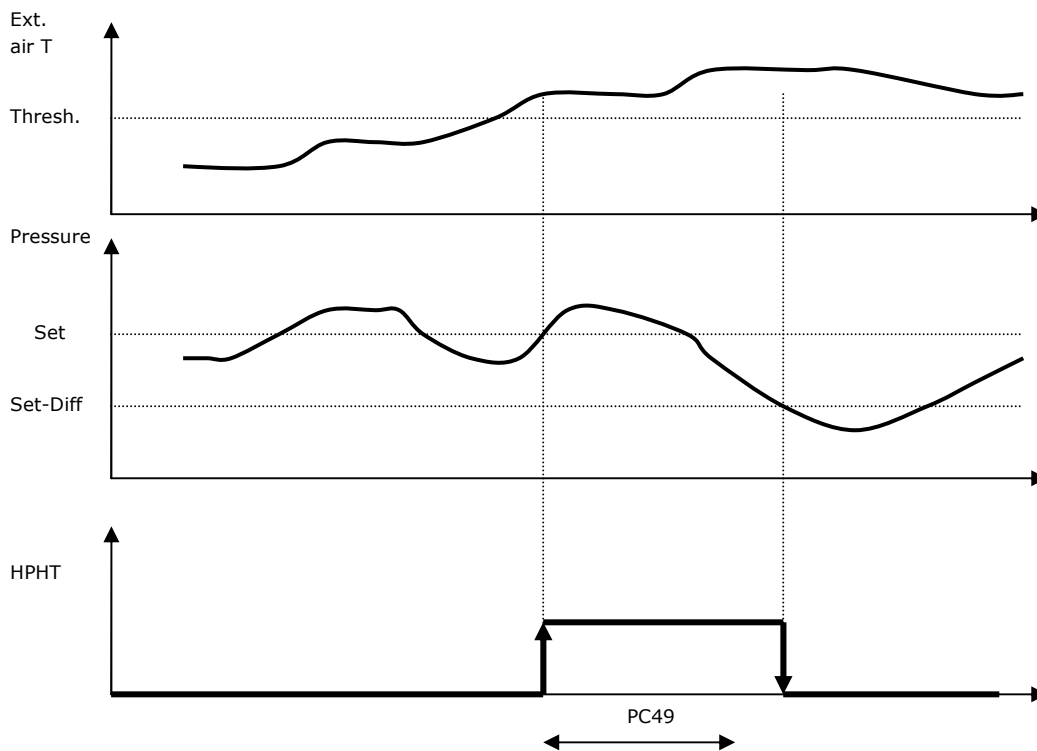

This control can only be enabled in summer operating mode (chiller).

**8.19.5 Low-pressure partialization at low temperatures (heat pump)**

This control makes it possible to partialize the refrigerating circuit power when outdoor air temperature and refrigerated water temperature conditions lead to the triggering of minimum-pressure alarms. If *less than 15 minutes* have elapsed since the triggering of a minimum-pressure alarm and pressure falls below a given threshold, circuit active-power partialization is forced, till the pressure climbs back over the threshold by a certain differential.

- PC50 = Pressure partialization enable at low temperatures
- PC51 = Pressure partialization set point at low temperatures
- PC52 = Pressure partialization differential at low temperatures
- PC53 = Low external air temperature threshold
- PC54 = Refrigerated-water high-temperature threshold
- PC55 = Delay for partialization from low pressure alarm.

According to the number of configured compressors, the power-limiting percentage is calculated on the basis of this parameter:

- PC32 = Power limiting for winter operation

In order to enable this control, the outdoor air temperature sensor must be enabled.

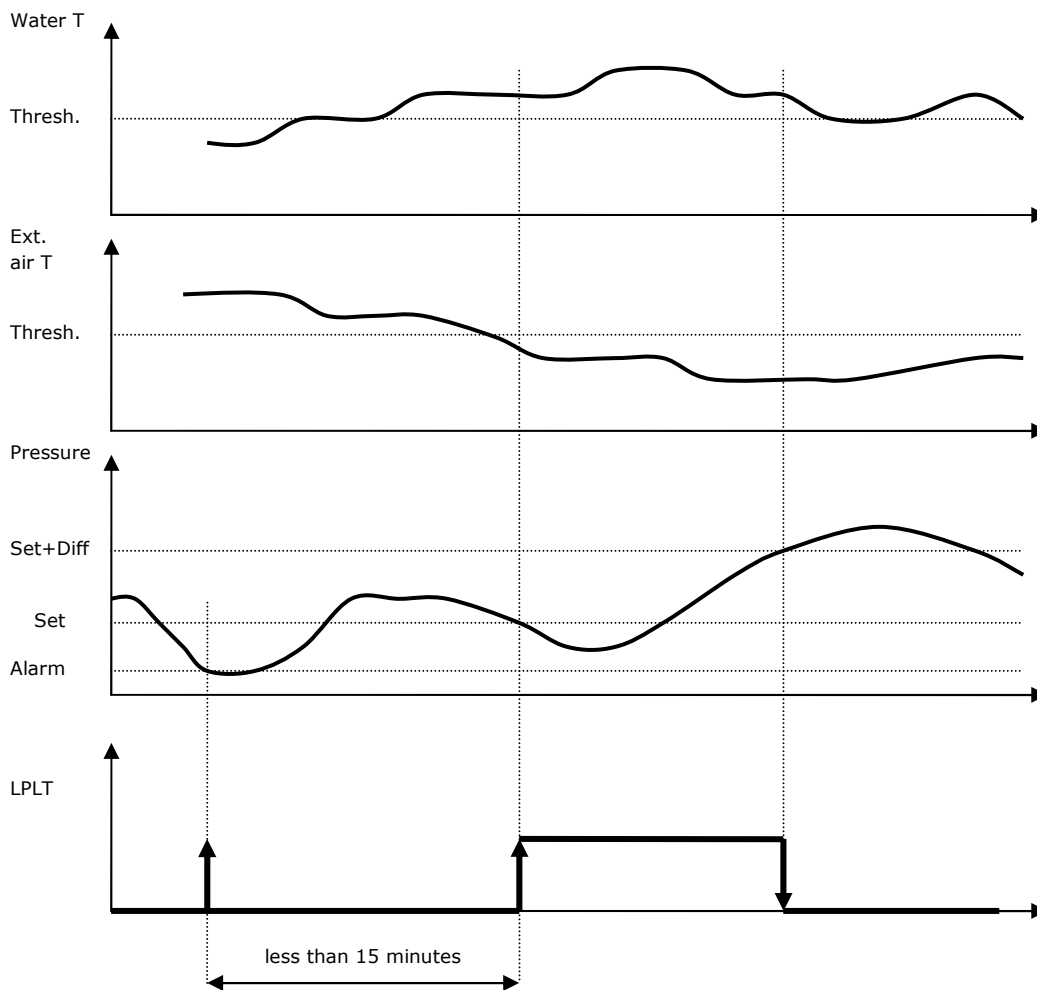

This control can only be enabled in winter operating mode (heat pump).

### 8.19.6 Operating limit management (heat pump)

When the external air temperature falls to particularly low levels, it may no longer be convenient or sufficient to heat using the heat pump. The *Limit set point PC17* on outdoor air temperature is used to disable the heat pump, Reactivation happens when the outdoor air temperature exceeds the *limit set point* plus a configurable *Limit differential PC72*.

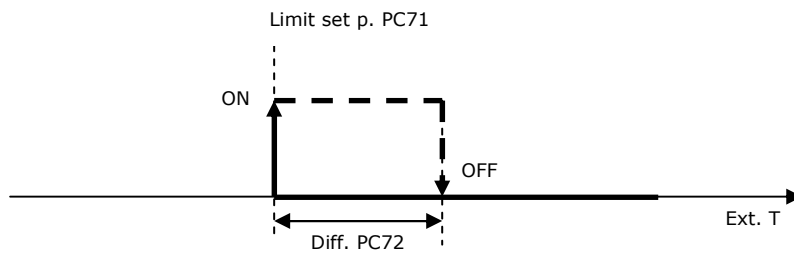

In order to enable this function, the outdoor air temperature sensor must be enabled.

### 8.19.7 Function of Cooling/Heating upon request

This function, if activated from the parameter *Enabling of Control on Request PC80*, requires a sensor of a specific remote temperature (normally placed in the accumulation tank): upon reaching a specific setpoint (in the cooling function *Control Setpoint on Summer Request PC81*, in the heating function *Control Setpoint on Winter Request PC82*) and after a *Delay of Control on Request PC85* causes the activation of the circulation pump and of the compressor to perform the requested function with the classic thermoregulation selected (regulation of receipt or dispatch). The unit turns off when the accumulation tank's needs have been satisfied, that is, once the *Control Setpoint on Summer Request PC81 - Control Differential on Summer Request PC83* (if cooling) has been reached or if the *Control Setpoint on Winter Request PC82 + Control Differential on Winter Request PC84* (if heating).

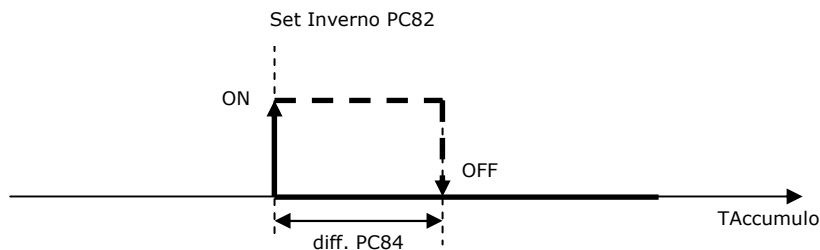

In order to use this feature, it is necessary to enable the auxiliary regulation probe via parameters *HAxx*.

### 8.19.8 Set-point change from digital input

It is possible to modify the working set-point by making use of digital input. In order to use this feature, set the offsets of the set-point with parameters *PUC1* (Summer function) and *PUH1* (Winter function).

It is also necessary to configure the digital input to be used by configuring parameters *HBxx*.

## 8.20 Management of EVDRIVE03 integrated into the system

The management of the electronic valve must be optimised and not limited to a classical overheating control.

There are several conditions and regulations that must consider other system variables as a whole, as well as the overheating variables (evaporation temperature and pressure) in a way to limit the problems due to the delays introduced by the temperature probe in the same and its positioning. These functions must be enabled from parameter in a way that the manufacturer can exclude them. If parameter PG05 has value 1, the external module EVDRIVE03 will be enabled (1 for each circuit). In this case the I/O of the module is used for regulation and in case there is no communication with EVDRIVE03 the alarm EVM1 (circuit 1) or EVM2 (circuit 2) is shown, after a delay PA99 in seconds.

### 8.20.1 Enabling of EEV operation

The controller knows when it is the time to activate the unit (switch a compressor on) and must consequently enable operation of the EVDRIVE03 driver via CAN bus.

Operation enabling must precede compressor switch-on by a few seconds. The valve must be "prepared" in an open manner by a suitable percentage for the compressor being switched on.

### 8.20.2 PID parameters set

EVDRIVE03 envisions 2 independent sets of parameter to use in the cooling (and defrosting) and heating operating modes. The controller must be able to select the most appropriate parameters set on the basis of the operating mode. The set to use may simply be selected from the 2 available or the parameters could be passed directly (PV parameters can be reached from the manufacturer menu).

### 8.20.3 Modulation of the SH set

- If the DSH is lower than 10K, liquid may return to the compressor - to counter this phenomena it is useful to raise the SH set.
- If the differential is higher than 20K there is no risk of liquid returning – considering the "favourable" condition in relation to safety of the compressor the SH set can be reduced to increase system efficiency (reduction of the condensation pressure and increase of the evaporation pressure).

These variations will have a minimum and a maximum and will be parameter sable as per figure.

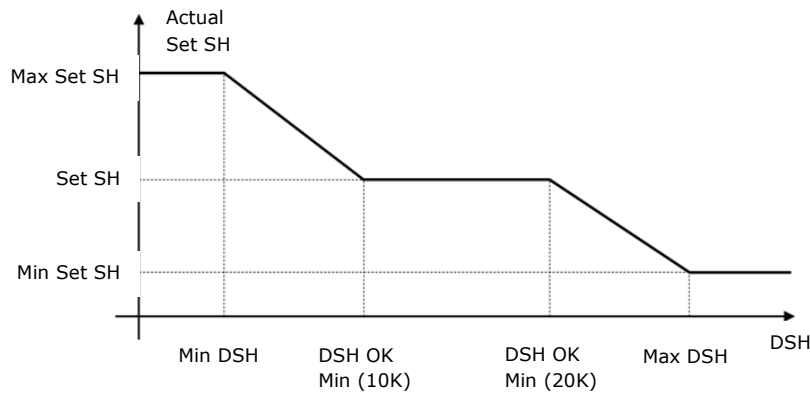

In this way, the risk of liquid return to the compressor is limited and system efficiency is increased according to the machine work conditions.

### 8.20.4 CAN Configuration

In order to correctly configure the valves of the two circuits, the CAN address and the baud-rate of each EVDRIVE03 need to be set.

The Circuit 1 valve must have the address CAN=11, while the Circuit 2 valve must have the address CAN=12.

The baud-rate for CAN communication must be set according to parameter PH99.



## 8.21 Manual operation

The program allows the setting of manual operation for compressors, fans and pumps. In this condition, devices are not involved in rotations, nor in thermo control calculations, although they do remain sensitive to any alarms.

Manual operation of devices proves useful when functional tests are to be carried out on the machine, to ascertain its integrity and correct functioning.

### 8.21.1 Compressors

Manual operation of compressors is guaranteed by parameter *Compressor enable PM1x*:

If set to *Auto*, it defines the normal behavior of the device;

If set to *Manu*, it disables the compressor, switching it to manual operation.

A compressor in manual operation mode does not take part in controls, and can be forced in its number of steps that it can provide, by acting on the property *Compressor forcing PM2x* (present in the *MAin->MANumenu*).

As already previously mentioned, however, the compressor remains sensitive to any alarms and related consequences.

In order to bring the compressor back to normal operation, parameter *Compressor enable PM1x* must be re-set to *Auto* (Automatic) value; otherwise, the compressor in question would continue to operate manually, thus failing to comply with any start/stop requests calculated by the configured control.

### 8.21.2 Fans

Manual or automatic operation of the two condensing fans and free-cooling dedicated fan is guaranteed by parameters *PM51* (Circuit # 1), *PM52* (Circuit # 2) and *PM65* (Free-Cooling Fan):

- If set to *Auto*, it defines the normal behavior of the device;
- If set to *Manu*, it disables the fan, switching it to manual operation.

A manually-operated fan does not take part in controls, and can be forced ON/OFF acting on parameters *PM63,PM64,PM67* and modulation acting on parameters *PM61,PM62 and PM66*.

As already previously mentioned, however, the fan remains sensitive to any alarms and related consequences.

In order to bring the fan back to normal operation, parameter *PM51/PM52/PM65* must be re-set to "A" (Automatic) value; otherwise, the fan in question would continue to operate manually, thus failing to comply with any start/stop requests calculated by the configured control.

### 8.21.3 Pumps

Manual or automatic operation of the circulating pump and source pumps is guaranteed by parameters *PM35*(Pump# 1), *PM36* (Pump# 2) and *PM45* (Source Pump# 1), *PM46* (Source Pump# 2):

- If set to *Auto*, it defines the normal behavior of the device;
- If set to *Manu*, it disables the fan, switching it to manual operation.

A manually-operated pump does not take part in controls, and can be forced ON/OFF acting on parameters *PM37, PM38* and on parameters *PM47, PM48* for source pumps.

As already previously mentioned, however, the pump remains sensitive to any alarms and related consequences.

In order to bring the pump back to normal operation, parameter *PM35/PM36/PM45/PM56* must be re-set to "A" (Automatic) value; otherwise, the pump in question would continue to operate manually, thus failing to comply with any start/stop requests calculated by the configured control.

### 8.22 Resetting of default parameters

Using the "Parameter resetting" procedure, all system parameters can be reset to their original default values. After entering the *InSt->MAP* menu – which is only accessible while the machine is switched OFF – set parameter PH15=1 and wait for the "0" value to reappear on the display; the system will automatically reset all parameters back to their default values.

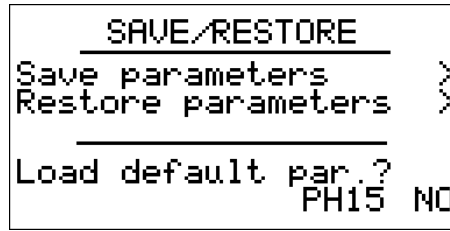

After this operation, it is necessary to power down the machine and then power it up again, to avoid the risk of malfunctions.

### 8.23 Parametering key

The values of all system parameters can be saved on the parametering key USB, to be subsequently copied to one or more compatible devices, or in a dedicated area in controller memory. This function is available from the menu *Installer->Parameters Map*.

#### Display LCD

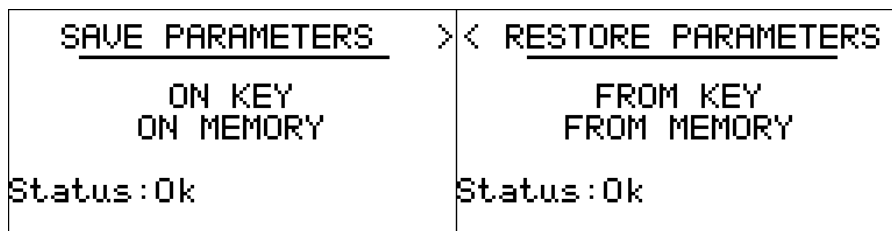

Display LED	
PH15	0/1
SAvE	USb
rEST	USb
SAvE	MEM
rEST	MEM

**Note:** Information relating to the product and product version is stored onto the parametering key, thus allowing the transfer of parameter maps only between devices which are compatible with one another.

## 9 WIRING DIAGRAM

### 9.1 Connection layout c-pro 3 micro CHIL

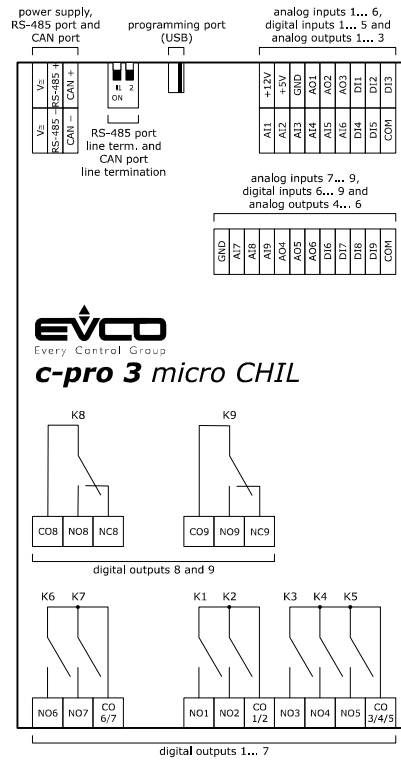

The following table shows the connection layout of **c-pro 3 micro CHIL**.

<b>c-pro 3 micro CHIL</b>	
<b>Digital outputs 1... 7</b>	
<b>TERMINAL</b>	<b>MEANING</b>
<b>NO6</b>	Normally open contact digital output 6
<b>NO7</b>	Normally open contact digital output 7
<b>CO6/7</b>	Common digital outputs 6 and 7
<b>NO1</b>	Normally open contact digital output 1
<b>NO2</b>	Normally open contact digital output 2
<b>CO1/2</b>	Common digital outputs 1 and 2
<b>NO3</b>	Normally open contact digital output 3
<b>NO4</b>	Normally open contact digital output 4
<b>NO5</b>	Normally open contact digital output 5
<b>CO3/4/5</b>	Common digital outputs 3, 4 and 5
<b>Digital outputs 8 and 9</b>	
<b>TERMINAL</b>	<b>MEANING</b>
<b>CO8</b>	Common digital outputs 8
<b>NO8</b>	Normally open contact digital output 8
<b>NC8</b>	Normally closed contact digital output 8
<b>CO9</b>	Common digital outputs 9
<b>NO9</b>	Normally open contact digital output 9
<b>NC9</b>	Normally closed contact digital output 9
<b>RS-485 port</b>	
<b>TERMINAL</b>	<b>MEANING</b>
<b>GND</b>	Ground
<b>A/+</b>	Terminal 1 of the transceiver

<b>B/-</b>	Terminal 0 of the transceiver
<b>Analog inputs 7... 9, digital inputs 6... 9 and analog outputs 4... 6.</b>	
TERMINAL	MEANING
<b>GND</b>	Common analog inputs and analog outputs
<b>AI7</b>	Analog input 7
<b>AI8</b>	Analog input 8
<b>AI9</b>	Analog input 9
<b>AO4</b>	Analog output 4
<b>AO5</b>	Analog output 5
<b>AO6</b>	Analog output 6
<b>DI6</b>	Digital input 6
<b>DI7</b>	Digital input 7
<b>DI8</b>	Digital input 8
<b>DI9</b>	Digital input 9
<b>COM</b>	Common digital inputs
<b>Power supply RS-485 port with Modbus</b>	
TERMINAL	MEANING
<b>V=</b>	Power supply controller
<b>A/+</b>	Terminal 1 of the transceiver RS-485 port
<b>B/-</b>	Terminal 0 of the transceiver RS-485 port
<b>CAN +</b>	Signal + CAN port
<b>CAN -</b>	Signal - CAN port
<b>USB</b>	
TERMINAL	MEANING
<b>USB</b>	USB OTG port
<b>Analog inputs 1... 6, digital inputs 1... 5 and analog outputs 1... 3.</b>	
TERMINAL	MEANING
<b>AI1</b>	Analog input 1
<b>AI2</b>	Analog input 2
<b>AI3</b>	Analog input 3
<b>AI4</b>	Analog input 4
<b>AI5</b>	Analog input 5
<b>AI6</b>	Analog input 6
<b>DI4</b>	Digital input 4
<b>DI5</b>	Digital input 5
<b>COM</b>	Common digital inputs
<b>+12V</b>	Power supply transducers
<b>5VS</b>	Power supply radiometric transducers
<b>GND</b>	Common analog inputs and analog outputs
<b>AO1</b>	Analog output 1
<b>AO2</b>	Analog output 2
<b>AO3</b>	Analog output 3
<b>DI1</b>	Digital input 1
<b>DI2</b>	Digital input 2
<b>DI3</b>	Digital input 3

## 9.2 Connection layout c-pro 3 EXP micro+

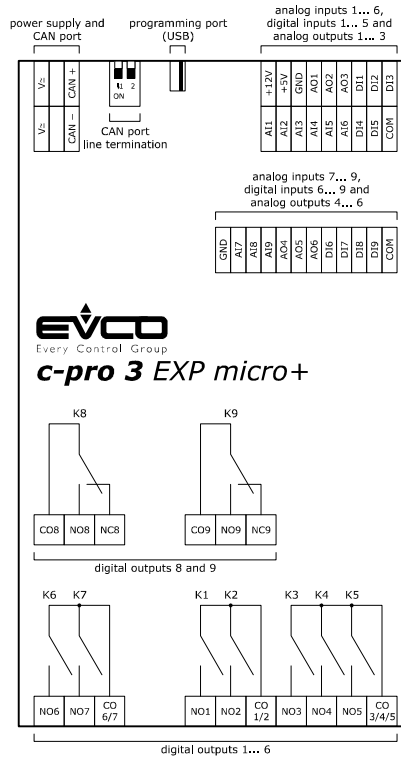

The following table shows the connection layout of **c-pro 3 EXP micro+**

<b>c-pro 3 EXP micro+</b>	
<b>Digital outputs 1... 7</b>	
<b>TERMINAL</b>	<b>MEANING</b>
<b>NO6</b>	Normally open contact digital output 6
<b>NO7</b>	Normally open contact digital output 7
<b>CO6/7</b>	Common digital outputs 6 and 7
<b>NO1</b>	Normally open contact digital output 1
<b>NO2</b>	Normally open contact digital output 2
<b>CO1/2</b>	Common digital outputs 1 and 2
<b>NO3</b>	Normally open contact digital output 3
<b>NO4</b>	Normally open contact digital output 4
<b>NO5</b>	Normally open contact digital output 5
<b>CO3/4/5</b>	Common digital outputs 3, 4 and 5
<b>Digital outputs 8 and 9</b>	
<b>TERMINAL</b>	<b>MEANING</b>
<b>CO8</b>	Common digital outputs 8
<b>NO8</b>	Normally open contact digital output 8
<b>NC8</b>	Normally closed contact digital output 8
<b>CO9</b>	Common digital outputs 9
<b>NO9</b>	Normally open contact digital output 9
<b>NC9</b>	Normally closed contact digital output 9
<b>Analog inputs 7... 9, digital inputs 6... 9 and analog outputs 4... 6.</b>	
<b>TERMINAL</b>	<b>MEANING</b>
<b>GND</b>	Common analog inputs and analog outputs
<b>AI7</b>	Analog input 7
<b>AI8</b>	Analog input 8

<b>AI9</b>	Analog input 9
<b>AO4</b>	Analog output 4
<b>AO5</b>	Analog output 5
<b>AO6</b>	Analog output 6
<b>DI6</b>	Digital input 6
<b>DI7</b>	Digital input 7
<b>DI8</b>	Digital input 8
<b>DI9</b>	Digital input 9
<b>COM</b>	Common digital inputs
<b>CAN port</b>	
<b>TERMINAL</b>	<b>MEANING</b>
<b>V+</b>	Power supply device
<b>V-</b>	Power supply device
<b>A/+</b>	Reserved
<b>B/-</b>	Reserved
<b>CAN+</b>	Signal + CAN port
<b>CAN-</b>	Signal - CAN port
<b>USB</b>	
<b>TERMINAL</b>	<b>MEANING</b>
<b>USB</b>	USB OTG port
<b>Analog inputs 1... 6, digital inputs 1... 5 and analog outputs 1... 3.</b>	
<b>TERMINAL</b>	<b>MEANING</b>
<b>AI1</b>	Analog input 1
<b>AI2</b>	Analog input 2
<b>AI3</b>	Analog input 3
<b>AI4</b>	Analog input 4
<b>AI5</b>	Analog input 5
<b>AI6</b>	Analog input 6
<b>DI4</b>	Digital input 4
<b>DI5</b>	Digital input 5
<b>COM</b>	Common digital inputs
<b>+12V</b>	Power supply
<b>5VS</b>	Power supply
<b>GND</b>	Common analog inputs and analog outputs
<b>AO1</b>	Analog output 1
<b>AO2</b>	Analog output 2
<b>AO3</b>	Analog output 3
<b>DI1</b>	Digital input 1
<b>DI2</b>	Digital input 2
<b>DI3</b>	Digital input 3

### 9.3 Connection layout *EVDRIVE03*

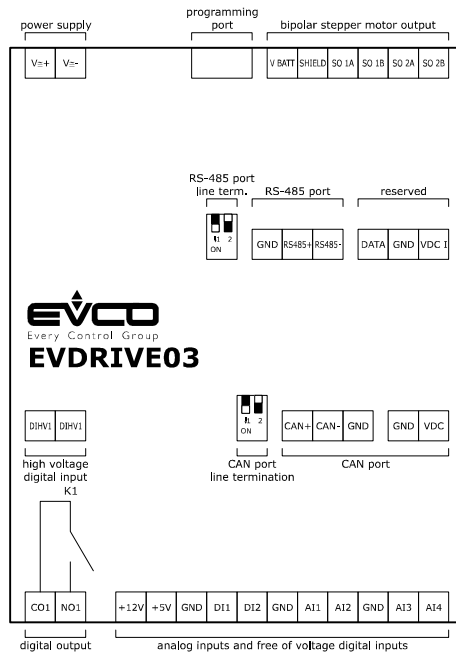

The following table shows the connection layout of *EVDRIVE03*

<b>EVDRIVE03</b>	
<b>Digital output</b>	
<b>TERMINAL</b>	<b>MEANING</b>
<b>CO1</b>	Common digital output
<b>NO1</b>	Normally open contact digital output
<b>Analog inputs and free of voltage digital inputs</b>	
<b>TERMINAL</b>	<b>MEANING</b>
<b>+12V</b>	Power supply
<b>+5V</b>	Power supply
<b>GND</b>	Ground analog inputs and free of voltage digital inputs
<b>DI1</b>	Digital input 1
<b>DI2</b>	Digital input 2
<b>GND</b>	Ground analog inputs and free of voltage digital inputs
<b>AI1</b>	Analog input 1
<b>AI2</b>	Analog input 2
<b>GND</b>	Ground analog inputs and free of voltage digital inputs
<b>AI3</b>	Analog input 3
<b>AI4</b>	Analog input 4
<b>CAN port</b>	
<b>TERMINAL</b>	<b>MEANING</b>
<b>CAN+</b>	Signal +
<b>CAN-</b>	Signal -
<b>GND</b>	Ground
<b>CANBUS communication protocol</b>	
<b>TERMINAL</b>	<b>MEANING</b>
<b>GND</b>	Ground
<b>VDC</b>	Power supply remote user interface
<b>AI8</b>	Analog input 8

<b>Bipolar stepper motor output</b>	
<b>TERMINAL</b>	<b>MEANING</b>
<b>V BATT</b>	Backup power supply input
<b>SHIELD</b>	Common bipolar stepper
<b>SO 1A</b>	Bipolar stepper motor coil 1
<b>SO 1B</b>	Bipolar stepper motor coil 1
<b>SO 2A</b>	Bipolar stepper motor coil 2
<b>SO 2B</b>	Bipolar stepper motor coil 2
<b>Power supply</b>	
<b>TERMINAL</b>	<b>MEANING</b>
<b>V+</b>	Power supply device
<b>V-</b>	Power supply device
<b>RS-485 port</b>	
<b>TERMINAL</b>	<b>MEANING</b>
<b>GND</b>	Ground
<b>RS485+</b>	D1=A=+
<b>RS485-</b>	D0=B=+
<b>High voltage digital input</b>	
<b>TERMINAL</b>	<b>MEANING</b>
<b>DIHV1</b>	High voltage digital input



### 9.4 Connection layout *Vgraph*

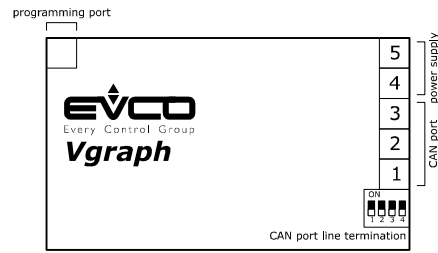

The following table shows the connection layout of *Vgraph*

<b>Vgraph</b>	
<b>Connector 1: CAN port</b>	
<b>PIN</b>	<b>MEANING</b>
<b>1</b>	Ground
<b>2</b>	Signal -
<b>3</b>	Signal +
<b>Connector 2: power supply</b>	
<b>PIN</b>	<b>MEANING</b>
<b>4</b>	Power supply
<b>5</b>	Power supply

### 9.5 c-pro 3 micro CHIL

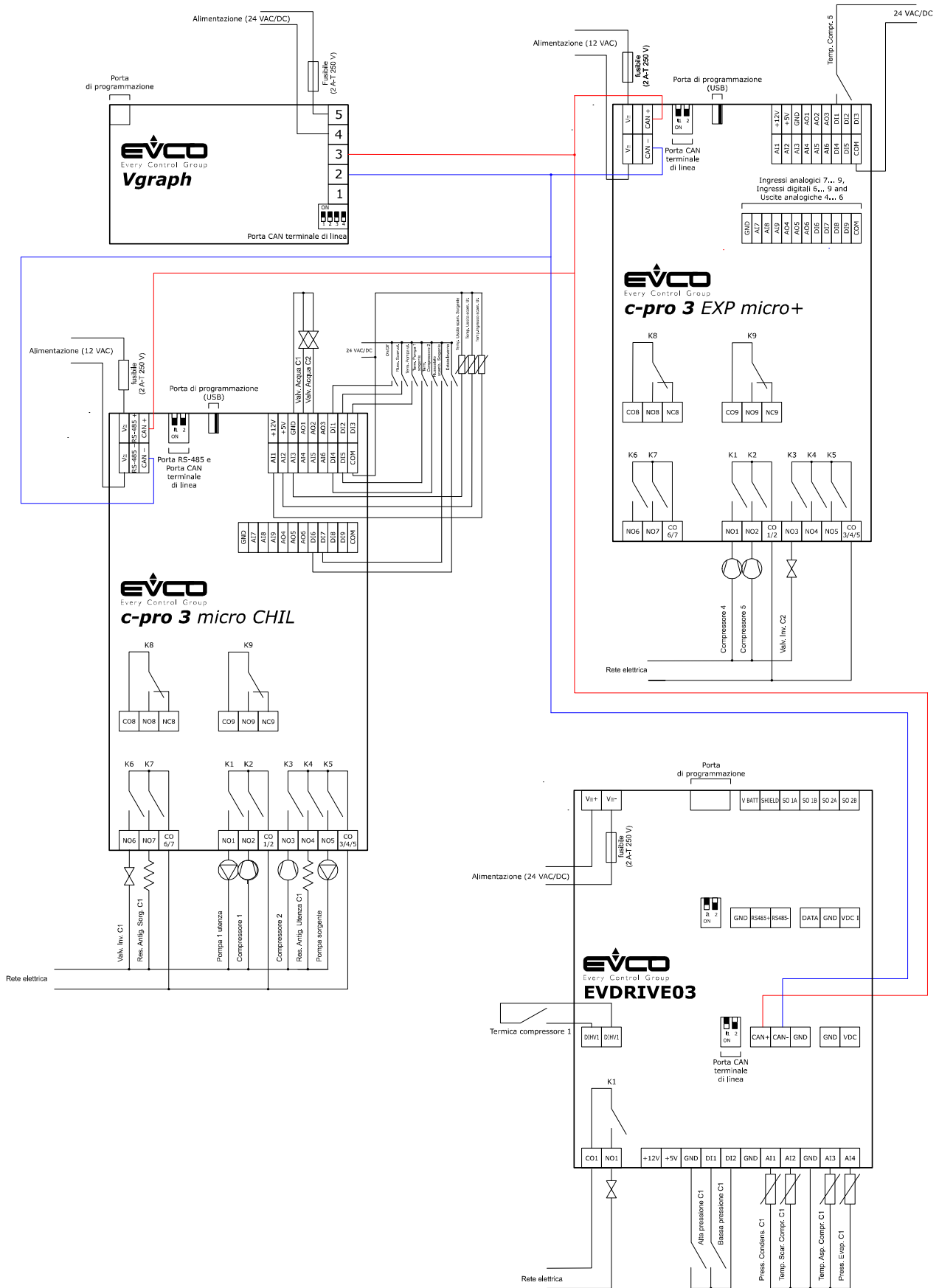

**The power supply of the devices must be galvanically isolated among them.**

### 9.5.1 Table of connection c-pro 3 micro CHIL

PGUT=11 (2 Circuit)	
<b>Controller Analog Inputs</b>	
A/I 1	Heat sink exchanger input temperature
A/I 2	Heat sink exchanger output temperature
A/I 3	Heat source exchanger output temperature
<b>Expansion Analog Inputs</b>	
A/I	<i>Not used</i>
<b>Analog Inputs EVDRIVE03 circuit 1</b>	
A/I 1	Condensing pressure C1 (4-20mA)
A/I 2	Compressor discharge temperature C1
A/I 3	Compressor intake temperature C1
A/I 4	Evaporation pressure C1 (4-20mA)
<b>Controller Digital Inputs</b>	
D/I 1	On/Off
D/I 2	Heat sink exchanger flow meter
D/I 3	Heat sink heat pump 1
D/I 4	Thermal compressor 2
D/I 5	Heat source heat pump 1
D/I 6	Summer/Winter
D/I 7	Heat source exchanger flow meter
<b>Expansion Digital Inputs</b>	
D/I 1	Thermal compressor 5
<b>Digital Inputs EVDRIVE03 circuit 1</b>	
D/I 1	High pressure C1
D/I 2	Low pressure C1
D/I 3	Thermal compressor 1
<b>Controller Analog Outputs</b>	
A/O 1	Water valve C1 (0-10V)
A/O 2	Water valve C2 (0-10V)
<b>Expansion Analog Outputs</b>	
A/O	<i>Not used</i>
<b>Controller Digital Outputs</b>	
D/O 1	Heat sink pump 1
D/O 2	Compressor 1
D/O 3	Compressor 2
D/O 4	Heat sink anti-frost resistance C1
D/O 5	Source pump
D/O 6	Reversing valve C1
D/O 7	Heat source anti-frost resistance C1
<b>Expansion Digital Outputs</b>	
D/O 1	Compressor 4
D/O 2	Compressor 5
D/O 3	Reversing valve C2
<b>Digital Outputs EVDRIVE03 circuit 1</b>	
D/O VCM 1	Solenoid valve C1

## 10 DIAGNOSTICS

The application is capable of managing a whole series of alarms, relating to compressors, fans, circuits and plant functions. Depending on the various alarm types, it is possible to configure their resetting (whether manual or automatic), a possible notification delay and any actions to be taken in that specific case.

When one or more alarms are active, the alarm icon flashes on displays.

In order to view the various alarms, the "Alarm" menu must be displayed from the main page, using the ESC key, followed by the ENTER key. By pressing the ESC key from an alarm page, or waiting for the 60-second timeout, the user is brought back to the application's main page.

To scroll the various active alarms, the ENTER key must be pressed once more: alarms are listed in order of priority, just as they are listed in the Alarm Table of chapter 6.4.

### 10.1 Manual and Automatic Alarms

There are two types of alarms: those that are manually reset and those that are automatically reset. These alarms offer the end-user the choice of selecting, via the associated parameter, the resetting mode that better reflects the user's own requirements.

### 10.2 Manual-reset alarms

When a manual-reset alarm is triggered:

- The alarm icon starts flashing.

By pressing the ENTER key from the "Alarm" menu, the code of the first active alarm is displayed.

Once the conditions which had triggered the alarm are back to normal, the alarm can be manually reset. To carry out this operation:

- Go to the page of the alarm to be reset;
- Hold the ENTER key pressed down for about 2 seconds.

At this point, in the absence of any further alarms, the page showing "none" is displayed, the alarm icon is switched OFF, and the machine goes back to normal operation; otherwise, the code relating to the next active alarm will be displayed.

The consequences deriving from an active manual-reset alarm remain valid as long as the user does not take care of deleting the alarm message.

### 10.3 Automatic-reset alarms

When an auto-reset alarm is triggered:

- The alarm icon starts flashing.

By pressing the ENTER key from the "Alarm" menu, the code of the first active alarm is displayed.

Once the conditions that had triggered the alarm are back to normal, resetting and deletion of the alarm message automatically take place, without any need for user intervention.

The consequences deriving from an active auto-reset alarm remain valid as long as the causes that triggered the alarm are not reset.

## 10.4 Alarm Table

All alarms managed by the application are listed below. The listing order is the same as the one in which alarms are listed when active.

Code	Alarm description	Type	Consequence	Notes
AL01	Input low temperature	S/A	Notification only or compressors and pump OFF	Heat pump only Settable delay
AL02	Input high temperature	S/A	Notification only or compressors and pump OFF	Chiller only Settable delay
AL03	Primary exchanger efficiency Circuit #1	Manu	Keeps all circuit compressors OFF	Settable delay
AL13	Primary exchanger efficiency Circuit #2	Manu	Keeps all circuit compressors OFF	
AL05	Evaporator flow meter	A/M	Compressors OFF Pump ON for T-secs.	Settable delay In manual stop, pump OFF
AL11	High-pressure pressure switch Circuit #1	Manu	All circuit compressors OFF	
AL12	High-pressure pressure switch Circuit #2	Manu	All circuit compressors OFF	
AL21	Low-pressure pressure switch Circuit #1	A/M	All circuit compressors and fans OFF	Settable start-up delay and rpm
AL22	Low-pressure pressure switch Circuit #2	A/M	All circuit compressors and fans OFF	
AL31	Transducer high pressure Circuit #1	Manu	All circuit compressors OFF	
AL32	Transducer high pressure Circuit #2	Manu	All circuit compressors OFF	
AL41	Transducer low pressure Circuit #1	A/M	All circuit compressors OFF	Settable start-up delay and rpm
AL42	Transducer low pressure Circuit #2	A/M	All circuit compressors OFF	
AL51	Failed start-up for low pressure Circuit #1	Auto	Keeps all circuit compressors OFF	
AL52	Failed start-up for low pressure Circuit #2	Auto	Keeps all circuit compressors OFF	
AL61	High temperature discharge gas compressors Circuit #1	A/M	All circuit compressors OFF	Settable delay
AL62	High temperature discharge gas compressors Circuit #2	A/M	All circuit compressors OFF	
AL81	Evaporator anti-frost Circuit #1	Manu	Circuit compressors OFF and Pump ON for T-secs.	
AL82	Evaporator anti-frost Circuit #2	Manu	Circuit compressors OFF and Pump ON for T-secs.	
AF20	Thermal switch external fan free-cooling	A/M	Fan FC OFF	Settable delay
AC21	Thermal switch compressor #1	A/M	Compressor # 1 OFF	Settable delay
AC22	Thermal switch compressor #2	A/M	Compressor # 2 OFF	
AC23	Thermal switch compressor #3	A/M	Compressor # 3 OFF	
AC24	Thermal switch compressor #4	A/M	Compressor # 4 OFF	
AC25	Thermal switch compressor #5	A/M	Compressor # 5 OFF	
AC26	Thermal switch compressor #6	A/M	Compressor # 6 OFF	
AP21	Thermal switch pump #1	A/M	Pump # 1 OFF	<i>If it is the only pump, turn off all compressors and fans; otherwise try to turn on the other pump.</i>
AP22	Thermal switch pump #2	A/M	Pump # 2 OFF	
AP23	Thermal switch source pump #1	A/M	Source Pump # 1 OFF	<i>If it is the only pump, turn off all compressors and fans; otherwise try to turn on the other pump.</i>
AP24	Thermal switch source pump #2	A/M	Source Pump # 2 OFF	
AF21	Thermal switch fan Circuit #1	A/M	Fan # 1 OFF	Settable delay
AF22	Thermal switch fan Circuit #2	A/M	Fan # 2 OFF	
AC01	Operating hours compressor #1	Auto	Display only	

AC02	Operating hours compressor #2	Auto	Display only	
AC03	Operating hours compressor #3	Auto	Display only	
AC04	Operating hours compressor #4	Auto	Display only	
AC05	Operating hours compressor #5	Auto	Display only	
AC06	Operating hours compressor #6	Auto	Display only	
AP01	Operating hours pump #1	Auto	Display only	
AP02	Operating hours pump #2	Auto	Display only	
AP03	Operating hours source pump #1	Auto	Display only	
AP04	Operating hours source pump #2	Auto	Display only	
AF01	Operating hours fan Circuit #1	Auto	Display only	
AF02	Operating hours fan Circuit #2	Auto	Display only	
AL06	Source flow meter	A/M	Compressors OFF Pump ON for T-secs.	Settable delay In manual stop, pump OFF
AL83	Source anti-frost Circuit #1	Manu	Circuit compressors OFF and Pump ON for T-secs.	
AL84	Source anti-frost Circuit #2	Manu	Circuit compressors OFF and Pump ON for T-secs.	
ERTC	RTC Alarm broken or discharged	A/M	Inhibits management of RTC	-
EN01	Expansion communication alarm	Auto	Display only	Settable delay
EVM1	EVCM Circuit #1 communication alarm	Auto	All circuit compressors OFF	Settable delay
EVM2	EVCM Circuit #2 communication alarm	Auto	All circuit compressors OFF	Settable delay
ES01	External ambient temperature probe	Auto	Inhibits functions using it	
ES02	System input temperature probe (FC)	Auto	Inhibits functions using it	
ES03	Remote aux. temperature probe aux (accumulation tank)	Auto	Inhibits functions using it	
ES04	Heat sink exchanger input temperature probe	Auto	Settable number of ON compressors	
ES05	Circuit 1 heat sink exchanger output temperature probe	Auto	Settable number of ON compressors	
ES06	Circuit 1 heat source exchanger output temperature probe	Auto	Inhibits functions using it	
ES07	Circuit 1coil temperature probe	Auto	Inhibits functions using it	
ES08	Circuit 1 condenser pressure probe	Auto	Settable fan forcing	
ES09	Circuit 1 evaporation pressure probe	Auto	Settable fan forcing	
ES10	Circuit 1 single pressure probe	Auto	Settable fan forcing	
ES11	Circuit 1 compressor discharge temperature probe	Auto	Inhibits functions using it	
ES12	Circuit 1 compressor intake temperature probe	Auto	Inhibits functions using it	Settable delay
ES13	Circuit 2 heat sink exchanger output temperature probe	Auto	Settable number of ON compressors	
ES14	Circuit 2 heat source exchanger output temperature probe	Auto	Inhibits functions using it	
ES15	Circuit 2 coil temperature probe	Auto	Inhibits functions using it	
ES16	Circuit 2 condenser probe	Auto	Settable fan forcing	
ES17	Circuit 2 evaporation probe	Auto	Settable fan forcing	
ES18	Circuit 2 single pressure probe	Auto	Settable fan forcing	
ES19	Circuit 2 compressor discharge temperature probe	Auto	Inhibits functions using it	
ES20	Circuit 2 compressor intake temperature probe	Auto	Inhibits functions using it	
AHW1	Duplicate configuration of analog input	Auto	Display only	
AHW2	Duplicate configuration of digital input	Auto	Display only	
AF03	Operating hours fan free-cooling	Auto	Display only	

**Note:** (\*1) If this is the only pump, it switches OFF all compressors and fans; otherwise, it switches ON the other pump.

S/A = Notification - only or auto-reset alarm (settable via parameter).

A/M = Auto or manual-reset alarm (settable via parameter or by number of events/hour).

### 10.5 Alarms History

The controller memorizes in a suitable (non volatile) memory zone organized like the FIFO queue, the ALARM HISTORY, or rather it could be a list of the last alarms verified.

In order to view the alarm history, choose "Show HISTORY" from the general Menu, or from the main page by pressing ESC.

Show ALARMS >>> Show HISTORY >>>	<hr/> <b>HISTORY</b> <hr/> STATUS: OK  Element N° 12 Code: AL22 10/12/2013 14:13:20
-------------------------------------	------------------------------------------------------------------------------------------------------------------------------------------------------------------------------------

Each element of the history is associated with the following information:

- progressive number for the alarm
- mnemonic code of the alarm (AL01, AL03, ...)
- date and hours in which alarm has been verified.

The code for every alarm is that which is presented in the alarm table. The storage capacity of the history is 100 events.

Using the parameter *PH30 (Cancel Alarm History)* it is possible to eliminate from history all the elements memorized; set the parameter to YES (1) and wait a couple of seconds until the re-reading of the default value NO (0).

**Note 1.** In the case where the memory capacity has reached it's full limit (i.e. 100 events recorded) and you wish to memorize/record another event, the first event initially stored in memory would be overwritten with the new event. The same would follow for other elements.

**Note 2.** The history is enabled only if the parameter *PG04=1*, or if the system clock is enabled.



## 11 LIST OF Modbus® VARIABLES

The application can be controlled via a supervisor, using the Modbus® protocol. Communication takes place via an RS485 serial interface, which is already incorporated into the controller.

Addr Base 0	Addr Base 1	Name	Value	Min	Max	Description	Mode
0x0100	257	Packed_DI1	0	0	65535	bit00=DI01, bit01=DI02, bit02=DI03, bit03=DI04, bit04=DI05, bit05=DI06, bit06=DI07, bit07=DI08, bit08=DI09, bit09=DI10, bit10=DI11, bit11=DI12	R/W
0x0101	258	Packed_DI2	0	0	65535	bit00=DI01, bit01=DI02, bit02=DI03, bit03=DI04, bit04=DI05, bit05=DI06, bit06=DI07, bit07=DI08, bit08=DI09, bit09=DI10, bit10=DI11, bit11=DI12	R/W
0x0102	259	PackDI_Logic_1	0	0	65535	bit00=DI01, bit01=DI02, bit02=DI03, bit03=DI04, bit04=DI05, bit05=DI06, bit06=DI07, bit07=DI08, bit08=DI09, bit09=DI10, bit10=DI11, bit11=DI12	R/W
0x0103	260	PackDI_Logic_2	0	0	65535	bit00=DI01, bit01=DI02, bit02=DI03, bit03=DI04, bit04=DI05, bit05=DI06, bit06=DI07, bit07=DI08, bit08=DI09, bit09=DI10, bit10=DI11, bit11=DI12	R/W
0x0104	261	PackDI_Logic_3	0	0	65535	bit00=DI01, bit01=DI02, bit02=DI03, bit03=DI04, bit04=DI05, bit05=DI06, bit06=DI07, bit07=DI08, bit08=DI09, bit09=DI10, bit10=DI11, bit11=DI12	R/W
0x0180	385	PackDO_Logic_1	0	0	65535		R/W
0x0181	386	PackDO_Logic_2	0	0	65535		R/W
0x0182	387	PackDO_Logic_3	0	0	65535		R/W
0x0200	513	Probe_TExtern	0.0	- 3276.8	3276.7		R/O
0x0201	514	Probe_TAux	0.0	- 3276.8	3276.7		R/O
0x0202	515	Probe_TIn_FC	0.0	- 3276.8	3276.7		R/O
0x0203	516	Probe_TIn	0.0	- 3276.8	3276.7		R/O
0x0204	517	Probe_TOut_C1	0.0	- 3276.8	3276.7		R/O
0x0205	518	Probe_TOutSorg_C1	0.0	- 3276.8	3276.7		R/O
0x0206	519	Probe_TCoil_C1	0.0	- 3276.8	3276.7		R/O
0x0207	520	Probe_TGasDischarge_C1	0.0	- 3276.8	3276.7		R/O
0x0208	521	Probe_TSuction_C1	0.0	- 3276.8	3276.7		R/O
0x0209	522	Probe_PCond_C1	0.0	- 3276.8	3276.7		R/O
0x020A	523	Probe_PEvap_C1	0.0	- 3276.8	3276.7		R/O
0x020B	524	Probe_PUnique_C1	0.0	- 3276.8	3276.7		R/O
0x020C	525	Probe_TOut_C2	0.0	- 3276.8	3276.7		R/O
0x020D	526	Probe_TOutSorg_C2	0.0	- 3276.8	3276.7		R/O
0x020E	527	Probe_TCoil_C2	0.0	- 3276.8	3276.7		R/O

0x020F	528	Probe_TGasDischarge_C2	0.0	- 3276.8	3276.7		R/O
0x0210	529	Probe_TSuction_C2	0.0	- 3276.8	3276.7		R/O
0x0211	530	Probe_PCond_C2	0.0	- 3276.8	3276.7		R/O
0x0212	531	Probe_PEvap_C2	0.0	- 3276.8	3276.7		R/O
0x0213	532	Probe_PUnique_C2	0.0	- 3276.8	3276.7		R/O
0x0280	641	vAO_Fan_C1	0.00	0.00	100.00		R/W
0x0281	642	vAO_Fan_C2	0.00	0.00	100.00		R/W
0x0282	643	vAO_Fan_Ext_FC	0.00	0.00	100.00		R/W
0x0283	644	vAO_Valve_FC	0.00	0.00	100.00		R/W
0x0284	645	vAO_Valve_Water_C1	0.00	0.00	100.00		R/W
0x0285	646	vAO_Valve_Water_C2	0.00	0.00	100.00		R/W
0x0300	769	PackedAlarm_1	0	0	65535		R/W
0x0301	770	PackedAlarm_2	0	0	65535		R/W
0x0302	771	PackedAlarm_3	0	0	65535		R/W
0x0303	772	PackedAlarm_4	0	0	65535		R/W
0x0304	773	PackedAlarm_5	0	0	65535		R/W
0x0305	774	BMS_AC21a26[0]	0	0	1		R/W
0x0306	775	BMS_AC21a26[1]	0	0	1		R/W
0x0307	776	BMS_AC21a26[2]	0	0	1		R/W
0x0308	777	BMS_AC21a26[3]	0	0	1		R/W
0x0309	778	BMS_AC21a26[4]	0	0	1		R/W
0x030A	779	BMS_AC21a26[5]	0	0	1		R/W
0x030B	780	BMS_AF20	0	0	1		R/W
0x030C	781	BMS_AF21	0	0	1		R/W
0x030D	782	BMS_AF22	0	0	1		R/W
0x030E	783	BMS_AL03	0	0	1		R/W
0x030F	784	BMS_AL05	0	0	1		R/W
0x0310	785	BMS_AL06	0	0	1		R/W
0x0311	786	BMS_AL11	0	0	1		R/W
0x0312	787	BMS_AL12	0	0	1		R/W
0x0313	788	BMS_AL13	0	0	1		R/W
0x0314	789	BMS_AL21	0	0	1		R/W
0x0315	790	BMS_AL22	0	0	1		R/W
0x0316	791	BMS_AL31	0	0	1		R/W
0x0317	792	BMS_AL32	0	0	1		R/W
0x0318	793	BMS_AL41	0	0	1		R/W
0x0319	794	BMS_AL42	0	0	1		R/W

0x031A	795	BMS_AL61	0	0	1		R/W
0x031B	796	BMS_AL62	0	0	1		R/W
0x031C	797	BMS_AL81	0	0	1		R/W
0x031D	798	BMS_AL82	0	0	1		R/W
0x031E	799	BMS_AL83	0	0	1		R/W
0x031F	800	BMS_AL84	0	0	1		R/W
0x0320	801	BMS_AP21	0	0	1		R/W
0x0321	802	BMS_AP22	0	0	1		R/W
0x0322	803	BMS_AP23	0	0	1		R/W
0x0323	804	BMS_AP24	0	0	1		R/W
0x0324	805	BMS_ERTC	0	0	1		R/W
0x0400	1025	OnOffBySuperv	0	0	1	ON/OFF machine by supervisor	R/W
0x0401	1026	FuncModeBySuperv	0	0	1	Operating Mode by supervisor	R/W
0x0500	1281	CLOCK_RTC ( Low )	-	01/01/ 2000	19/01/ 2068 3.14.0 7	Real Time Clock	R/W
0x0501	1282	CLOCK_RTC ( High )					
0x0502	1283	UIUnitStatus	0	0	8	Unit status	R/W
0x0503	1284	ModoUnita	0	0	5	0=OFF, 1=Chiller, 2=PdC, 3=Defrost, 4=Dripping, 5=FreeCooling	R/W
0x0504	1285	UI_Mode	0	0	1	Operation Mode	R/W
0x0505	1286	vGeneralAlarm	0	0	1		R/W
0x0506	1287	SetpointSummer_Actual	8.5	- 3276.8	3276.7	Actual Setpoint summer	R/W
0x0507	1288	SetpointWinter_Actual	44.0	- 3276.8	3276.7	Actual Setpoint winter	R/W
0x0508	1289	Probe_TempReg	0.0	- 3276.8	3276.7		R/O
0x0509	1290	Pump1_Status	0	0	4	Status pump 1	R/W
0x050A	1291	Pump2_status	0	0	4	Status pump 2	R/W
0x050B	1292	Source_Pump1_Status	0	0	4	Status pump 1	R/W
0x050C	1293	Source_Pump2_status	0	0	4	Status pump 2	R/W
0x050D	1294	UI_FreeCooling_On	0	0	1		R/W
0x050E	1295	UI_defrost_C1orC2[0]	0	0	2	Defrost status (circuit)	R/W
0x050F	1296	vCntOnDefrost_C1	0	0	65535		R/W
0x0510	1297	vCntWatDefrost_C1	0	0	65535		R/W
0x0511	1298	StatusCompressors[0]	0	0	6	Status compressor	R/W
0x0512	1299	StatusCompressors[1]	0	0	6	Status compressor	R/W
0x0513	1300	StatusCompressors[2]	0	0	6	Status compressor	R/W

0x0514	1301	UI_FanStatus[0]	0	0	255		R/W
0x0515	1302	UI_defrost_C1orC2[1]	0	0	2	Defrost status (circuit)	R/W
0x0516	1303	vCntOnDefrost_C2	0	0	65535		R/W
0x0517	1304	vCntWatDefrost_C2	0	0	65535		R/W
0x0518	1305	StatusCompressors[3]	0	0	6	Status compressor	R/W
0x0519	1306	StatusCompressors[4]	0	0	6	Status compressor	R/W
0x051A	1307	StatusCompressors[5]	0	0	6	Status compressor	R/W
0x051B	1308	UI_FanStatus[1]	0	0	255		R/W
0x0600	1537	PT01_enabWorkingDay1Zone1	0	0	1	PT01 - Enable zone 1 of working day 1	R/W
0x0601	1538	PT02_StartDay1TZ_1 ( Low )	0.00 .00	0.00.00	23.59. 59	PT02 - Start time day 1 zone 1	R/W
0x0602	1539	PT02_StartDay1TZ_1 ( High )					
0x0603	1540	PT03_EndDay1TZ_1 ( Low )	0.00 .00	0.00.00	23.59. 59	PT03 - End time day 1 zone 1	R/W
0x0604	1541	PT03_EndDay1TZ_1 ( High )					
0x0605	1542	PT04_day1_OffsetCoolingDay1TZ_1	0.0	-36.0	36.0	PT04 - Offset cooling day 1 zone 1	R/W
0x0606	1543	PT05_OffsetHeatingDay1TZ_2	0.0	-36.0	36.0	PT05 - Offset heating day 1 zone 1	R/W
0x0607	1544	PT06_enabWorkingDay1Zone2	0	0	1	PT06 - Enable zone 2 of working day 1	R/W
0x0608	1545	PT07_StartDay1TZ_2 ( Low )	0.00 .00	0.00.00	23.59. 59	PT07 - Start time day 1 zone 2	R/W
0x0609	1546	PT07_StartDay1TZ_2 ( High )					
0x060A	1547	PT08_EndDay1TZ_2 ( Low )	0.00 .00	0.00.00	23.59. 59	PT08 - End time day 1 zone 2	R/W
0x060B	1548	PT08_EndDay1TZ_2 ( High )					
0x060C	1549	PT09_OffsetCoolingDay1TZ_2	0.0	-36.0	36.0	PT09 - Offset cooling day 1 zone 2	R/W
0x060D	1550	PT10_OffsetHeatingDay1TZ_2	0.0	-36.0	36.0	PT10 - Offset heating day 1 zone 2	R/W
0x060E	1551	PT11_enabWorkingDay2Zone1	0	0	1	PT11 - Enable zone 1 of working day 2	R/W
0x060F	1552	PT12_StartDay2TZ_1 ( Low )	0.00 .00	0.00.00	23.59. 59	PT12 - Start time day 2 zone 1	R/W
0x0610	1553	PT12_StartDay2TZ_1 ( High )					
0x0611	1554	PT13_EndDay2TZ_1 ( Low )	0.00 .00	0.00.00	23.59. 59	PT13 - End time day 2 zone 1	R/W
0x0612	1555	PT13_EndDay2TZ_1 ( High )					
0x0613	1556	PT14_OffsetCoolingDay2TZ_1	0.0	-36.0	36.0	PT14 - Offset cooling day 2 zone 1	R/W

0x0614	1557	PT15_OffsetHeatingDay2TZ_1	0.0	-36.0	36.0	PT15 - Offset heating day 2 zone 1	R/W
0x0615	1558	PT16_enabWorkingDay2Zone2	0	0	1	PT16 - Enable zone 2 of working day 2	R/W
0x0616	1559	PT17_StartDay2TZ_2 ( Low )	0.00 .00	0.00.00	23.59. 59	PT17 - Start time day 2 zone 2	R/W
0x0617	1560	PT17_StartDay2TZ_2 ( High )					
0x0618	1561	PT18_EndDay2TZ_2 ( Low )	0.00 .00	0.00.00	23.59. 59	PT18 - End time day 2 zone 2	R/W
0x0619	1562	PT18_EndDay2TZ_2 ( High )					
0x061A	1563	PT19_OffsetCoolingDay2TZ_2	0.0	-36.0	36.0	PT19 - Offset cooling day 2 zone 2	R/W
0x061B	1564	PT20_OffsetHeatingDay2TZ_2	0.0	-36.0	36.0	PT20 - Offset heating day 2 zone 2	R/W
0x061C	1565	PT21_typeDay_Monday	1	0	2	PT21 - Daily program Monday	R/W
0x061D	1566	PT22_typeDay_Tuesday	1	0	2	PT22 - Daily program Tuesday	R/W
0x061E	1567	PT23_typeDay_Wednesday	1	0	2	PT23 - Daily program Wednesday	R/W
0x061F	1568	PT24_typeDay_Thursday	1	0	2	PT24 - Daily program Thursday	R/W
0x0620	1569	PT25_typeDay_Friday	1	0	2	PT25 - Daily program Friday	R/W
0x0621	1570	PT26_typeDay_Saturday	0	0	2	PT26 - Daily program Saturday	R/W
0x0622	1571	PT27_typeDay_Sunday	0	0	2	PT27 - Daily program Sunday	R/W
0x0623	1572	MOdE_OperatingMode	0	0	1	0=Cool (Chiller), 1=Heat (PdC)	R/W
0x0624	1573	SPC1_SetpointSummer	8.5	-15.0	73.0	SPC1 - Setpoint summer (Chiller)	R/W
0x0625	1574	SPH1_SetpointInverno	44.0	23.0	158.0	SPH1 - Setpoint winter (HP)	R/W
0x0626	1575	PUC1_OffsetSummer_DI	2.0	-36.0	36.0	PUC1 - Offset Set Summer DI	R/W
0x0627	1576	PUH1_OffsetWinter_DI	2.0	-36.0	36.0	PUH1 - Offset Set Winter DI	R/W
0x0628	1577	PM00_Limit_HourCmp ( Low )	2000 .0	0.0	9999.0	PM00 - Maintenance interval compressors	R/W
0x0629	1578	PM00_Limit_HourCmp ( High )					
0x062A	1579	PM01_OperatingHoursCmp1 ( Low )	0.0	0.0	9999.0	PM01 - Operating Hours Cmp 1	R/W
0x062B	1580	PM01_OperatingHoursCmp1 ( High )					
0x062C	1581	PM02_OperatingHoursCmp2 ( Low )	0.0	0.0	9999.0	PM02 - Operating Hours Cmp 2	R/W
0x062D	1582	PM02_OperatingHoursCmp2 ( High )					
0x062E	1583	PM03_OperatingHoursCmp3 ( Low )	0.0	0.0	9999.0	PM03 - Operating Hours Cmp 3	R/W

0x062F	1584	PM03_OperatingHoursCmp3 ( High )					
0x0630	1585	PM04_OperatingHoursCmp4 ( Low )	0.0	0.0	9999.0	PM04 - Operating Hours Cmp 4	R/W
0x0631	1586	PM04_OperatingHoursCmp4 ( High )					
0x0632	1587	PM05_OperatingHoursCmp5 ( Low )	0.0	0.0	9999.0	PM05 - Operating Hours Cmp 5	R/W
0x0633	1588	PM05_OperatingHoursCmp5 ( High )					
0x0634	1589	PM06_OperatingHoursCmp6 ( Low )	0.0	0.0	9999.0	PM06 - Operating Hours Cmp 6	R/W
0x0635	1590	PM06_OperatingHoursCmp6 ( High )					
0x0636	1591	PM30_Limit_HourPump ( Low )	2000.0	0.0	9999.0	PM30 - Maintenance interval pumps	R/W
0x0637	1592	PM30_Limit_HourPump ( High )					
0x0638	1593	PM31_OperatingHoursPump1 ( Low )	0.0	0.0	9999.0	PM31 - Operating Hours Pump1	R/W
0x0639	1594	PM31_OperatingHoursPump1 ( High )					
0x063A	1595	PM32_OperatingHoursPump2 ( Low )	0.0	0.0	9999.0	PM32 - Operating Hours Pump2	R/W
0x063B	1596	PM32_OperatingHoursPump2 ( High )					
0x063C	1597	PM33_OperatingHoursSorgPump1 ( Low )	0.0	0.0	9999.0	PM33 - Operating Hours Sorg Pump1	R/W
0x063D	1598	PM33_OperatingHoursSorgPump1 ( High )					
0x063E	1599	PM34_OperatingHoursSorgPump2 ( Low )	0.0	0.0	9999.0	PM34 - Operating Hours Sorg Pump2	R/W
0x063F	1600	PM34_OperatingHoursSorgPump2 ( High )					
0x0640	1601	PM40_Limit_HourFan ( Low )	2000.0	0.0	9999.0	PM40 - Maintenance interval fans	R/W
0x0641	1602	PM40_Limit_HourFan ( High )					
0x0642	1603	PM41_OperatingHoursFan1 ( Low )	0.0	0.0	9999.0	PM41 - Operating Hours Fan1	R/W
0x0643	1604	PM41_OperatingHoursFan1 ( High )					
0x0644	1605	PM42_OperatingHoursFan2 ( Low )	0.0	0.0	9999.0	PM42 - Operating Hours Fan1	R/W
0x0645	1606	PM42_OperatingHoursFan2 ( High )					
0x0646	1607	PM43_OperatingHours_Fan_FC ( Low )	0.0	0.0	9999.0	PM43 - Operating Hours Fan FC	R/W
0x0647	1608	PM43_OperatingHours_Fan_FC ( High )					
0x0648	1609	PM90_Last_mainten	01/0	01/01/	19/01/	PM90 - Last maintenance	R/W

		ance ( Low )	1/2000	2000	20683.14.07		
0x0649	1610	PM90_Last_maintenance ( High )					
0x064A	1611	PM11a16_EnabManual_Comp[0]	0	0	1	PM11 - Enable compressors manual operation	R/W
0x064B	1612	PM11a16_EnabManual_Comp[1]	0	0	1	PM11 - Enable compressors manual operation	R/W
0x064C	1613	PM11a16_EnabManual_Comp[2]	0	0	1	PM11 - Enable compressors manual operation	R/W
0x064D	1614	PM11a16_EnabManual_Comp[3]	0	0	1	PM11 - Enable compressors manual operation	R/W
0x064E	1615	PM11a16_EnabManual_Comp[4]	0	0	1	PM11 - Enable compressors manual operation	R/W
0x064F	1616	PM11a16_EnabManual_Comp[5]	0	0	1	PM11 - Enable compressors manual operation	R/W
0x0650	1617	PM21a26_ForceComp[0]	0	0	1		R/W
0x0651	1618	PM21a26_ForceComp[1]	0	0	1		R/W
0x0652	1619	PM21a26_ForceComp[2]	0	0	1		R/W
0x0653	1620	PM21a26_ForceComp[3]	0	0	1		R/W
0x0654	1621	PM21a26_ForceComp[4]	0	0	1		R/W
0x0655	1622	PM21a26_ForceComp[5]	0	0	1		R/W
0x0656	1623	PM35_EnabManual_Pump1	0	0	1	PM35 - Enable pump 1 manual operation	R/W
0x0657	1624	PM36_EnabManual_Pump2	0	0	1	PM36 - Enable pump 2 manual operation	R/W
0x0658	1625	PM37_ForceManual_Pump1	0	0	1	PM37 - Force pump 1	R/W
0x0659	1626	PM38_ForceManual_Pump2	0	0	1	PM38 - Force pump 1	R/W
0x065A	1627	PM45_EnabManual_SourcePump1	0	0	1	PM45 - Enable cond pump 1 manual operation	R/W
0x065B	1628	PM46_EnabManual_SourcePump2	0	0	1	PM46 - Enable cond pump 2 manual operation	R/W
0x065C	1629	PM47_ForceManual_SourcePump1	0	0	1	PM47 - Force cond pump 1	R/W
0x065D	1630	PM48_ForceManual_SourcePump2	0	0	1	PM48 - Force cond pump 2	R/W
0x065E	1631	PM51_EnabManual_FanC1	0	0	1	PM51 - Enable the manual/automatic operation of the condensing fan in Circuit # 1	R/W
0x065F	1632	PM52_EnabManual_FanC2	0	0	1	PM52 - Enable the manual/automatic operation of the condensing fan in Circuit # 2	R/W
0x0660	1633	PM61_ForzaturaInv Fan_C1	0.00	0.00	100.00		R/W
0x0661	1634	PM62_ForzaturaInv Fan_C2	0.00	0.00	100.00		R/W
0x0662	1635	PM63_ForzaturaInv	0	0	1	PM63 - Manual operation condensing fan Circuit # 1	R/W

		Fan_C1					
0x0663	1636	PM64_ForzaturaInv Fan_C2	0	0	1	PM64 - Manual operation condensing fan Circuit # 2	R/W
0x0664	1637	PM65_EnManuFan_ FC	0	0	1		R/W
0x0665	1638	PM66_ForceFanAO_ FC	0.00	0.00	100.00		R/W
0x0666	1639	PM67_ForseFanDO_ FC	0	0	1		R/W
0x0667	1640	PM71_Calib_TExter n	0.0	-18.0	18.0		R/W
0x0668	1641	PM72_Calib_TIn_FC	0.0	-18.0	18.0		R/W
0x0669	1642	PM73_Calib_TIn	0.0	-18.0	18.0		R/W
0x066A	1643	PM74_Calib_TOut_C 1	0.0	-18.0	18.0		R/W
0x066B	1644	PM75_Calib_TOut_C 2	0.0	-18.0	18.0		R/W
0x066C	1645	PM76_Calib_TOutSo rg_C1	0.0	-18.0	18.0		R/W
0x066D	1646	PM77_Calib_TOutSo rg_C2	0.0	-18.0	18.0		R/W
0x066E	1647	PM78_Calib_TCoil_C 1	0.0	-18.0	18.0		R/W
0x066F	1648	PM79_Calib_TCoil_C 2	0.0	-18.0	18.0		R/W
0x0670	1649	PM80_Calib_TGas_ C1	0.0	-18.0	18.0		R/W
0x0671	1650	PM81_Calib_TGas_ C2	0.0	-18.0	18.0		R/W
0x0672	1651	PM82_Calib_TAux	0.0	-18.0	18.0		R/W
0x0673	1652	PM83_Calib_PCond_ C1	0.0	-290.0	290.0		R/W
0x0674	1653	PM84_Calib_PCond_ C2	0.0	-290.0	290.0		R/W
0x0675	1654	PM85_Calib_PEvap_ C1	0.0	-290.0	290.0		R/W
0x0676	1655	PM86_Calib_PEvap_ C2	0.0	-290.0	290.0		R/W
0x0677	1656	PM87_Calib_PUniqu e_C1	0.0	-290.0	290.0		R/W
0x0678	1657	PM88_Calib_PUniqu e_C2	0.0	-290.0	290.0		R/W
0x0679	1658	PC01_Cmp_Rotatio n_Type	0	0	3	PC01 - Compressor rotation 0=FIFO, 1=LIFO, 2=FIFO+Hr, 3=LIFO+Hr	R/W
0x067A	1659	PC02_Compressors Mode	0	0	1	PC02 - Compressors mode (twin circuit) 0=balancing, 1=saturation	R/W
0x067B	1660	PC04_Cmp_TminOn	20	0	999	PC04 - Compressor min ON time	R/W
0x067C	1661	PC05_Cmp_TminOff	120	0	999	PC05 - Compressor rmin OFF time	R/W
0x067D	1662	PC06_Cmp_TonOn	360	0	999	PC06 - Min time between 2 startup of same comp	R/W



0x067E	1663	PC07_Cmp_TonOther	360	0	999	PC07 - Min time between 2 startup of different comp	R/W
0x067F	1664	PC08_Cmp_ToffOther	180	0	999	PC08 - Min time between 2 shutdown of different comp	R/W
0x0680	1665	PC09_MaxNumEvHour	8	4	12	PC09 - Max number of startups for every hour	R/W
0x0681	1666	PC10_CompressorInErrorProbe	1	0	3	PC10 - Number of compressors ON for circuit during error sensor	R/W
0x0682	1667	PC11_TypeRegulation	0	0	1	PC11 - Type of control	R/W
0x0683	1668	PC12_ProportionalLateralBand	2.5	1.0	36.0	PC12 - Proportional band lateral control	R/W
0x0684	1669	PC14_DeadZone	3.0	0.1	18.0	PC14 - Neutral zone	R/W
0x0685	1670	PC15_DeadZone_Min	1.0	0.1	18.0	PC15 - Min. value of compressor zero energy band	R/W
0x0686	1671	PC16_DeadZone_Max	5.0	0.1	18.0	PC16 - Max. value of compressor zero energy band	R/W
0x0687	1672	PC17_DeadZoneOutsideTime	20	0	999	PC17 - Release time compressor neutral zone control	R/W
0x0688	1673	PC18_DeadZoneAdaptive	0	0	1	PC18 - Enable adaptive control neutral zone control	R/W
0x0689	1674	PC21_MinValueSetChiller	5.0	-15.0	73.0	PC21 - Min Value Setpoint Summer (Chiller)	R/W
0x068A	1675	PC22_MaxValueSetChiller	20.0	15.0	73.0	PC22 - Max Value Setpoint Summer (Chiller)	R/W
0x068B	1676	PC23_MinValueSetHP	30.0	23.0	158.0	PC23 - Min setpoint winter (HP)	R/W
0x068C	1677	PC24_MaxValueSetHP	44.0	23.0	158.0	PC24 - Max setpoint winter (HP)	R/W
0x068D	1678	PC31_PowerLimitedSummer	50	0	100	PC31 - Power Limited Summer	R/W
0x068E	1679	PC32_PowerLimitedWinter	50	0	100	PC32 - Power Limited Winter	R/W
0x068F	1680	PC35_EnabForceShutdown	0	0	1	PC35 - Enable compressors force shutdown	R/W
0x0690	1681	PC36_SetForceSummer	3.5	-30.0	73.0	PC36 - Summer force shutdown setpoint	R/W
0x0691	1682	PC37_SetForceWinter	52.0	26.0	167.0	PC37 - Winter force shutdown setpoint	R/W
0x0692	1683	PC41_EnabPumpDown	1	0	2	PC41 - Enable Pump-Down	R/W
0x0693	1684	PC42_CompShutdownTime	5	0	240	PC42 - Compressor shutdown time in pumpdown	R/W
0x0694	1685	PC43_DiffPumpDown	1.5	0.0	72.5	PC43 - Threshold for Pump-Down disabling	R/W
0x0695	1686	PC45_EnabHPTC	0	0	1	PC45 - Enable high-temperature pressure-switch control	R/W
0x0696	1687	PC46_SetpointHPTC	27.0	0.0	652.5	PC46 - Pressure set point for high-temperature pressure-switch control	R/W
0x0697	1688	PC47_DiffHPTC	2.0	0.0	72.5	PC47 - Pressure differential for high-temperature pressure-switch control	R/W
0x0698	1689	PC48_ThresholdAirExtHPTC	12.0	-30.0	73.0	PC48 - External high temperature threshold for pressure-switch control	R/W

0x0699	1690	PC49_MinTimeHPTC	10	0	99	PC49 - Min. time for maintaining pressure-switch partialization	R/W
0x069A	1691	PC50_EnabPressControlLT	0	0	1	PC50 - Enable low-temperature pressure-switch control (heat pump)	R/W
0x069B	1692	PC51_SetControlPressostaticLP	3.2	0.0	145.0	PC51 - Pressure setpoint for low-temperature pressure-switch control	R/W
0x069C	1693	PC52_DiffControlPressostaticLT	2.0	0.0	145.0	PC52 - Differential pressure for pressostatic control at low temperature	R/W
0x069D	1694	PC53_SetMinAirExt	-5.0	-10.0	41.0	PC53 - Setpoint low external temperature for pressure control	R/W
0x069E	1695	PC54_SetMaxTempOut	48.0	30.0	158.0	PC54 - Setpoint low external temperature for pressostaticcontrol	R/W
0x069F	1696	PC55_DelayPartialization	900	0	999	PC55 - Delay for partialization from low pressure alarm	R/W
0x06A0	1697	PC61_SetCommutationSummer	20.0	0.0	158.0	PC61 - Setpoint commutation summer	R/W
0x06A1	1698	PC62_SetCommutationWinter	10.0	0.0	158.0	PC62 - Setpoint commutation winter	R/W
0x06A2	1699	PC64_offsetDynamicSetSummer	-10.0	-36.0	36.0	PC64 - Offset dynamic setpoint summer (Chiller)	R/W
0x06A3	1700	PC65_StartTempDynamicSPSummer	30.0	-27.0	126.0	PC65 - StartTemperature Dynamic Setpoint Summer (Chiller)	R/W
0x06A4	1701	PC66_EndTempDynamicSPSummer	60.0	-27.0	126.0	PC66 - End Temperature Dynamic Setpoint Summer (Chiller)	R/W
0x06A5	1702	PC67_offsetDynamicSetWinter	10.0	-36.0	36.0	PC67 - Offset dynamic setpoint winter (HP)	R/W
0x06A6	1703	PC68_StartTempDynamicSPWinter	0.0	-27.0	126.0	PC68 - StartTemperature Dynamic Setpoint Winter (HP)	R/W
0x06A7	1704	PC69_EndTempDynamicSPWinter	30.0	-27.0	126.0	PC66 - End Temperature Dynamic Setpoint Winter (HP)	R/W
0x06A8	1705	PC70_FunctionLimitManagement	0	0	2	PC70 - Function limit management	R/W
0x06A9	1706	PC71_FunctionLimitSetPoint	-7.0	-54.0	54.0	PC71 - Function limit setpoint	R/W
0x06AA	1707	PC72_FunctionLimitDiff	4.0	0.1	18.0	PC72 - Function limit differential	R/W
0x06AB	1708	PC80_AbilitaControllaRichiesta	0	0	1		R/W
0x06AC	1709	PC81_SetpointControllo_a_Richiesta_Estate	15.0	-15.0	70.0		R/W
0x06AD	1710	PC82_SetpointControllo_a_Richiesta_Inverno	45.0	-15.0	70.0		R/W
0x06AE	1711	PC83_DiffControllo_a_Richiesta_Estate	4.0	0.1	10.0		R/W
0x06AF	1712	PC84_DiffControllo_a_Richiesta_Inverno	4.0	0.1	10.0		R/W
0x06B0	1713	PC85_RitardoControlloSuRichiesta	5	0	999		R/W
0x06B1	1714	PF01_CondenserControlType	0	0	1	PF01 - Condenser control type	R/W
0x06B2	1715	PF02_EnFanWithCmp	1	0	1	PF02 - Enable fan control only if at least one compressor is ON	R/W

0x06B3	1716	PF03_StopFan_Defrost	0	0	1	PF03- Stop fan during defrost	R/W
0x06B4	1717	PF07_Fan_TonOther	10	0	999	PF07 - Fan Min Time between 2 starts	R/W
0x06B5	1718	PF08_Fan_ToffOther	20	0	999	PF08 - Min Time between 2 fan shutdown	R/W
0x06B6	1719	PF09_ForceInErrorProbe	0	0	1	PF09 - Fan operation in case of condensing sensor alarm	R/W
0x06B7	1720	PF10_ForceInErrorProbe	0.00	0.00	100.00	PF10 - Fan frequency in case of condensing sensor alarm	R/W
0x06B8	1721	PF11_SetCond_Chiller	20.0	5.0	652.5	PF11 - Setpoint condensation summer (Chiller)	R/W
0x06B9	1722	PF12_DiffCond_Chiller	12.0	0.1	217.5	PF12 - Differential condensation summer (Chiller)	R/W
0x06BA	1723	PF13_EnabForceMax	1	0	1	PF13 - Enable force max condensation	R/W
0x06BB	1724	PF14_SetForcingMaxCond_Chiller	26.0	15.0	652.5	PF14 - Setpoint max condensation summer (Chiller)	R/W
0x06BC	1725	PF15_DiffForcingMaxCond_Chiller	2.0	0.1	72.5	PF15 - Differential max condensation summer (Chiller)	R/W
0x06BD	1726	PF16_CoolingPI	0	0	999	PF08 - Integral time for control of valves (cooling)	R/W
0x06BE	1727	PF21_SetRegCond_HP	9.0	0.5	217.5	PF21 - Setpoint condensation winter (HP)	R/W
0x06BF	1728	PF22_DiffRegCond_HP	2.0	0.1	217.5	PF22 - Differential condensation winter (HP)	R/W
0x06C0	1729	PF24_SetForcingMaxCond_HP	3.2	0.5	290.0	PF24 - Setpoint max condensation winter (HP)	R/W
0x06C1	1730	PF25_DiffForcingMaxCond_HP	0.5	0.1	72.5	PF25 - Differential max condensation winter (HP)	R/W
0x06C2	1731	PF26_HeatingPI	0	0	999	PF08 - Integral time for control of valves (heating)	R/W
0x06C3	1732	PF27_MinVal_InverterFan	0.00	0.00	100.00	PF27 - Min value inverter for condensing forcing	R/W
0x06C4	1733	PF28_SpeedUp_InverterFan	4	0	999	PF28 - SpeedUp inverter condenser	R/W
0x06C5	1734	PF31_LimitMinCondensationLinear	30.00	0.00	100.00	PF31 - Min Limit regulation inverter condensation	R/W
0x06C6	1735	PF32_LimitMaxCondensationLinear	100.00	0.00	100.00	PF32 - Max Limit regulation inverter condensation	R/W
0x06C7	1736	PF33_EnabCutOff	1	0	1	PF33 - Enable fan control under min condensing limit	R/W
0x06C8	1737	PF34_DiffCutOff	2.0	0.0	72.5	PF34 - Switch-off differential under the minimum condensing limit (inverter)	R/W
0x06C9	1738	PF36_EnabFanPrestart	1	0	2	0=No, 1=Winter only, 2=Always	R/W
0x06CA	1739	PF38_FanPrestartSpeed	50.00	0.00	100.00		R/W
0x06CB	1740	PF39_FanPrestartTime	10	0	999		R/W
0x06CC	1741	PF41_LinInverterFan	25.00	0.00	100.00		R/W
0x06CD	1742	PF42_LinInverterFan	50.00	0.00	100.00		R/W
0x06CE	1743	PF43_LinInverterFan	75.00	0.00	100.00		R/W

0x06CF	1744	PF45_LinInverterFan	25.00	0.00	100.00		R/W
0x06D0	1745	PF46_LinInverterFan	50.00	0.00	100.00		R/W
0x06D1	1746	PF47_LinInverterFan	75.00	0.00	100.00		R/W
0x06D2	1747	Pd01_SetStartDefrost	6.0	0.0	652.5	Pd01 - Setpoint start defrost	R/W
0x06D3	1748	Pd02_SetStopDefrost	12.0	0.0	652.5	Pd02 - Setpoint stop defrost	R/W
0x06D4	1749	Pd03_WaitTimeStartDefrost	1200	60	9600	Pd03 - Waiting interval at defrost start	R/W
0x06D5	1750	Pd05_MaxTimeDefrost	300	10	600	Pd05 - Max duration of defrost	R/W
0x06D6	1751	Pd06_DrippingTime	120	0	600	Pd06 - Dripping time	R/W
0x06D7	1752	Pd07_MinTimeWaitAfterCmp	60	0	600	Pd07 - Min time to wait after compressor restart	R/W
0x06D8	1753	Pd20_EnabDefrostCompensation	0	0	1	Pd20 - Enable defrost compensation	R/W
0x06D9	1754	Pd21_SetStartCompensation	5.0	-30.0	70.0	Pd21 - Setpoint for defrosting compensation start	R/W
0x06DA	1755	Pd22_SetStopCompensation	0.0	-30.0	70.0	Pd22 - Setpoint for defrosting compensation stop	R/W
0x06DB	1756	Pd23_MaxTimeCompensation	3600	0	9600	Pd23 - Max waiting time at defrosting compensation stop	R/W
0x06DC	1757	PP01_PumpOperation	0	0	2	PP01 - Pump Operation	R/W
0x06DD	1758	PP02_TONcyclic	120	1	999	PP02 - Pump ON time in cyclic working	R/W
0x06DE	1759	PP03_TOFFcyclic	120	1	999	PP03 - Pump OFF time in cyclic working	R/W
0x06DF	1760	PP04_TMinPumpComp	60	1	999	PP04 - Min time between ON pump and ON comp	R/W
0x06E0	1761	PP05_DelayShutdownPumps	60	1	999	PP05 - Delay shutdown pumps	R/W
0x06E1	1762	PP07_ShutdownPumpInDefrost	0	0	1	PP07 - Shutdown pump during defrost	R/W
0x06E2	1763	PP08_DeltaHoursSwap	4	1	240	PP08 - Delta hours to swap pumps	R/W
0x06E3	1764	PP09_PumpOperatingTimeLowWater	15	0	999	PP09 - Operating time pump low water flow	R/W
0x06E4	1765	PP10_PumpOperatingTimeLowTemp	15	0	999	PP10 - Pump operating time at low temperature	R/W
0x06E5	1766	PP21_SourcePumpOperation	0	0	2		R/W
0x06E6	1767	Pr01_EnableAntiFreezeHeater	1	0	1	Pr01 - Enable antifreeze heater	R/W
0x06E7	1768	Pr02_SetpointHeater	5.0	-30.0	50.0	Pr02 - Setpoint heater	R/W
0x06E8	1769	Pr03_DiffHeater	2.0	0.1	18.0	Pr03 - Differential heater	R/W
0x06E9	1770	Pr04_ForceHeaterErrorProbe	0	0	1	Pr04 - Forcing of anti-frost heating elements when sensor error	R/W
0x06EA	1771	Pr05_SetpointAlarmAntifreeze	3.0	-30.0	50.0	Pr05 - Setpoint alarm antifreeze	R/W

0x06EB	1772	Pr06_DiffAlarmAntifreeze	2.0	0.1	18.0	Pr06 - Differential alarm antifreeze	R/W
0x06EC	1773	Pr11_EnableAntiFreezeHeater_Src	0	0	1	Pr11 - Enable antifreeze heater	R/W
0x06ED	1774	Pr12_SetpointHeater_Src	5.0	-30.0	50.0	Pr12 - Setpoint heater	R/W
0x06EE	1775	Pr13_DiffHeater_Src	2.0	0.1	18.0	Pr13 - Differential heater	R/W
0x06EF	1776	Pr14_ForceHeaterErrorProbe_Src	0	0	1	Pr14 - Forcing of anti-frost heating elements when sensor error	R/W
0x06F0	1777	Pr15_SetpointAlarmAntifreeze_Src	3.0	-30.0	50.0	Pr15 - Setpoint alarm antifreeze	R/W
0x06F1	1778	Pr16_DiffAlarmAntifreeze_Src	2.0	0.1	18.0	Pr16 - Differential alarm antifreeze	R/W
0x06F2	1779	PS01_Enable_FreeCooling	0	0	1		R/W
0x06F3	1780	PS02_DiffModulation_FC	3.0	0.1	20.0		R/W
0x06F4	1781	PS03_MinSpeed_FC	0.00	0.00	100.00		R/W
0x06F5	1782	PS04_MaxSpeed_FC	100.00	0.00	100.00		R/W
0x06F6	1783	PS05_Eanbel_FreeCooling_WithComp	1	0	1		R/W
0x06F7	1784	PS06_SetDiffEnable_FC	3.0	0.5	10.0		R/W
0x06F8	1785	PS07_Diff_FC	2.0	0.5	5.0		R/W
0x06F9	1786	PS08_DiffValveOnOff_FC	0.5	0.1	5.0		R/W
0x06FA	1787	PS09_DiffValveAO_FC	2.0	0.1	20.0		R/W
0x06FB	1788	PS10_MinTimeForFreeCooling	30	0	240		R/W
0x06FC	1789	PS15_Enable_FC_PartCond	1	0	1		R/W
0x06FD	1790	PS16_SetPartCond_FC	11.0	0.5	20.0		R/W
0x06FE	1791	PS17_DiffPartCond_FC	3.0	0.1	10.0		R/W
0x06FF	1792	PA01_FlowStartup_AlarmDelay	10	1	999	PA01 - Delay alarm flow from startUp	R/W
0x0700	1793	PA02_FlowRunning_AlarmDelay	1	1	999	PA02 - Delay Flow Running Alarm	R/W
0x0701	1794	PA03_NumberFlowAlarmaToManual	3	0	9	PA03 - Number flow alarm to became manual	R/W
0x0702	1795	PA04_DelayErrorProbe	10	0	240	PA04 - Delay error sensor	R/W
0x0703	1796	PA05_SetpointAlarmHighTemp	30.0	10.0	104.0	PA05 - Setpoint alarm high temperature	R/W
0x0704	1797	PA06_SetpointAlarmLowTemp	15.0	10.0	104.0	PA06 - Setpoint alarm low temperature	R/W
0x0705	1798	PA07_DelayTempAlarm	30	1	999	PA07 - Delay for temperature alarm	R/W
0x0706	1799	PA08_consequentTi	0	0	1	PA08 - Enable Temperature Alarm	R/W

		meForTempAlarm					
0x0707	1800	PA09_DifferentialAlarmTemp	0.5	0.1	18.0	PA09 - Differential alarm high/low temperature	R/W
0x0708	1801	PA10_DelayAfterUnitOn	15	0	999	PA10 - Delay temperature alarm after unit on	R/W
0x0709	1802	PA11_SetAlarmLowPress	3.0	0.1	143.5	PA11 - Setpoint alarm low pressure	R/W
0x070A	1803	PA12_DiffAlarmLowPress	1.0	0.1	58.0	PA12 - Differential alarm Low Pressure	R/W
0x070B	1804	PA13_TimeByPassAlarmLowPress	120	0	999	PA13 - Delay alarm low pressure	R/W
0x070C	1805	PA14_NumEvHourLP	3	0	5	PA14 - Number of alarms for manual restore type	R/W
0x070D	1806	PA16_EnableLPcontrolLowTemp	1	0	1	PA16 - Enable low pressure alarm at startUp with low temperature	R/W
0x070E	1807	PA17_SetAlarmLPwithLT	1.0	0.1	143.5	PA17 - Setpoint alarm low pressure with low temperature	R/W
0x070F	1808	PA18_DiffAlarmLowPressWithLowTemp	0.5	0.1	58.0	PA18 - Differential Alarm Low Pressure With Low Temperature	R/W
0x0710	1809	PA19_TimeActiveControlLPwithLT	120	10	999	PA19 - Time activation control low pressure with low temperature	R/W
0x0711	1810	PA20_DelayAlarmLPatStartUpCmp	240	0	999	PA20 - Delay alarm low pressure at startUp first compressor	R/W
0x0712	1811	PA21_SetHPal	28.0	0.0	652.5	PA21 - Setpoint high pressure alarm	R/W
0x0713	1812	PA22_DiffHPal	5.0	0.1	435.0	PA22 - Differential for reset high pressure alarm	R/W
0x0714	1813	PA25_EnableAllPrimaryExchanger	0	0	1	PA25 - Enable primary exchanger efficiency alarm	R/W
0x0715	1814	PA26_MinDiffPrimaryExchanger	2.0	0.1	36.0	PA26 - Min difference threshold for primary exchanger	R/W
0x0716	1815	PA27_ByPassAllPrimaryExchanger	120	0	999	PA27 - By-pass timer for primary exchanger efficiency alarm	R/W
0x0717	1816	PA30_EnableAlarmRTC	1	0	1	PA30 - Enable alarm RTC	R/W
0x0718	1817	PA31_ResetType_AlarmRTC	1	0	1	PA31 - Reset Type Alarm RTC	R/W
0x0719	1818	PA32_ThermalFanFC_Delay	10	0	999		R/W
0x071A	1819	PA33_ThermalFanFCResetType	1	0	1		R/W
0x071B	1820	PA40_Enable_Alarm_HourCmp	1	0	1	PA40 - Enable alarm of operating hours of compressors	R/W
0x071C	1821	PA41_ThermalCmp_Delay	10	0	999	PA41 - Delay of compressors thermal alarm	R/W
0x071D	1822	PA42_ThermalCmp_ResetType	1	0	1	PA42 - Type of reset for compressors thermal alarm	R/W
0x071E	1823	PA50_Enable_SourceFlowAlarm	0	0	1		R/W
0x071F	1824	PA51_SourceFlowStartup_AlarmDelay	10	1	999		R/W
0x0720	1825	PA52_SourceFlowRunning_AlarmDelay	1	1	999		R/W
0x0721	1826	PA53_MinFlowWaterValve	5.00	0.00	100.00		R/W

0x0722	1827	PA60_En_Alarm_HourPump	1	0	1	PA60 - Enable alarm operating hours pumps	R/W
0x0723	1828	PA61_En_Alarm_Hour_SourcePump	0	0	1		R/W
0x0724	1829	PA62_ThermalPump_ResetType	1	0	1		R/W
0x0725	1830	PA63_ThermalSorgPump_ResetType	1	0	1		R/W
0x0726	1831	PA71_RestoreTypeHighPressAl	1	0	1	PA71 - Type of reset for High pressure alarm	R/W
0x0727	1832	PA80_En_Alarm_HourFan	1	0	1	PA80 - Enable Operating Hour Alarm Fan	R/W
0x0728	1833	PA81_ThermalFan_Delay	10	0	999	PA81 - Delay of fan thermal alarm	R/W
0x0729	1834	PA82_ThermalFanResetType	1	0	1	PA82 - Type of reset for fan thermal alarm	R/W
0x072A	1835	PA85_SetpointAlarm_HTGas_C1	90.0	70.0	284.0		R/W
0x072B	1836	PA86_DiffAlarm_HTGas_C1	20.0	10.0	54.0		R/W
0x072C	1837	PA87_DelayAlarm_HTGas	30	0	999		R/W
0x072D	1838	PA88_ResetTypeAlarm_HTGas	1	0	1		R/W
0x072E	1839	PA89_SetpointAlarm_HTGas_C2	90.0	70.0	284.0		R/W
0x072F	1840	PA90_DiffAlarm_HTGas_C2	20.0	10.0	54.0		R/W
0x0730	1841	PA99_DelayExpAlarm	5	0	999	PA99 - Delay for expansion alarm	R/W
0x0731	1842	PH01_LowPressure_Min	0.0	-145.0	870.0	PH01 - Minimum pressure	R/W
0x0732	1843	PH02_LowPressure_Max	30.0	-145.0	870.0	PH02 - Maximum pressure	R/W
0x0733	1844	PH03_HighPressure_Min	0.0	-145.0	870.0	Bar/psi	R/W
0x0734	1845	PH04_HighPressure_Max	50.0	-145.0	870.0	Bar/psi	R/W
0x0735	1846	PH05_En_OnOffByKey	1	0	1	PH05 - Enable ON/OFF machine by key	R/W
0x0736	1847	PH06_En_ModeByChangeOver	0	0	1	PH06 - Enable automatic switchover summer/winter operating mode	R/W
0x0737	1848	PH07_En_OnOffByDI	0	0	1	PH07 - Enable ON/OFF machine by DI	R/W
0x0738	1849	PH08_En_ModeByDI	0	0	1	PH08 - Enable switchover summer/winter operating mode by DI	R/W
0x0739	1850	PH09_En_OnOffBySuperv	0	0	1	PH09 - Enable ON/OFF machine by supervisor	R/W
0x073A	1851	PH10_En_ModeBySup	0	0	1	PH10 - Enable switchover summer/winter operating mode by supervisor	R/W
0x073B	1852	PH11_Modbus_Address	1	1	247	PH11 - Modbus address	R/W
0x073C	1853	PH12_Modbus_Baud	3	1	4	PH12 - Modbus baud 0=1200, 1=2400,	R/W

						2=4800, 3=9600, 4=19200, 5=28800, 6=38400, 7=57600	
0x073D	1854	PH13_Modbus_Parity	2	0	2	PH13 - Modbus parity 0=NONE, 1=ODD, 2=EVEN	R/W
0x073E	1855	PH14_Modbus_Stop Bit	0	0	1	PH14 - Modbus stop bit 0=1 stop bit, 1=2 stop bits	R/W
0x073F	1856	PH15_FactoryDefault	0	0	1	PH15 - Reset parameter to factory defaults	R/W
0x0740	1857	PH16_En_bySchedule	0	0	1	PH16 - Enable ON/OFF machine by schedule	R/W
0x0741	1858	PH27_EnabDynamicSetPoint	0	0	1	PH27 - Enable Dynamic Setpoint	R/W
0x0742	1859	PH28_EnabsecSetby Sched	0	0	1	PH28 - Enable secondary Setpoint by Scheduler	R/W
0x0743	1860	PH30_HistoryReset	0	0	1	PH30 - Reset Alarm Log	R/W
0x0744	1861	PH31_Refrigeration Type	5	1	6	PH31 - Refrigerant type 1=R22, 2=R134a, 3=R404A, 4=R407C, 5=R410A, 6=R507	R/W
0x0745	1862	PH32_Temp_UM	0	0	1	PH32 - Temperature Unit 0=C, 1=F	R/W
0x0746	1863	PH33_Press_UM	0	0	1	PH33 - Pressure Unit 0=Bar, 1=psi	R/W
0x0747	1864	PH52_EnableEvcoIcon	1	0	1		R/W
0x0748	1865	PH53_Icon_Cool_Heat	0	0	1	PH53 - Mode icon Cool/Heat	R/W
0x0749	1866	PH90_Language	0	0	1	0=English, 1=Italian	R/W
0x074A	1867	PH99_CAN_1st_BaudRate	2	1	4	1=20K; 2=50K; 3=125K; 4=500K	R/W
0x074B	1868	PGUT	10	1	16		R/W
0x074C	1869	PG00_UnitType	3	1	4	PG00 - Unit Type 1:Air-to-water chiller 2: Air-to-water chiller + HP; 3:Water-to-water chiller; 4:Water-to-water chiller + HP	R/W
0x074D	1870	PG01_NumberCircuit	2	1	2	PG01 - Number of circuits	R/W
0x074E	1871	PG02_En_Expansion	1	0	1	PG02 - Enable Expansion	R/W
0x074F	1872	PG03_NumberCompCirc	2	1	3	PG03 - Number of compressors per circuit	R/W
0x0750	1873	PG04_En_RTC	1	0	1	PG04 - Enable real time clock (RTC)	R/W
0x0751	1874	PG05_En_EVCM	0	0	1	PG05 - Enable EVCM	R/W
0x0752	1875	PG09_PumpsNumber	1	0	2	PG09 - Pumps number	R/W
0x0753	1876	PG10_SourcePumpsNumber	1	0	2	PG10 - Source Pumps number	R/W
0x0754	1877	PG11_EnabUniqueCondensing	0	0	1	PG11 - Enable unique condensing;	R/W
0x0755	1878	PG12_enabSingleExc_Ut	1	0	1	PG12 - Enable single evaporation	R/W



0x0756	1879	PG13_FreeCool_Air Circuit	1	0	2	0=Uniquewith Condensing, 1=Separated FAN AO, 2=Separated FAN DO	R/W
0x0757	1880	PG14_enabSingleExc _Source	1	0	1		R/W
0x0758	1881	HA01	3	0	68		R/W
0x0759	1882	HA02	4	0	68		R/W
0x075A	1883	HA03	13	0	68		R/W
0x075B	1884	HA04	10	0	56		R/W
0x075C	1885	HA05	0	0	56		R/W
0x075D	1886	HA06	0	0	56		R/W
0x075E	1887	HA07	0	0	68		R/W
0x075F	1888	HA08	0	0	68		R/W
0x0760	1889	HA09	0	0	68		R/W
0x0761	1890	HA11	15	0	68		R/W
0x0762	1891	HA12	11	0	68		R/W
0x0763	1892	HA13	0	0	68		R/W
0x0764	1893	HA14	0	0	56		R/W
0x0765	1894	HA15	0	0	56		R/W
0x0766	1895	HA16	0	0	56		R/W
0x0767	1896	HA17	0	0	68		R/W
0x0768	1897	HA18	0	0	68		R/W
0x0769	1898	HA19	0	0	68		R/W
0x076A	1899	HB01_18[0]	3	0	44		R/W
0x076B	1900	HB01_18[1]	7	0	44		R/W
0x076C	1901	HB01_18[2]	11	0	44		R/W
0x076D	1902	HB01_18[3]	27	0	44		R/W
0x076E	1903	HB01_18[4]	21	0	44		R/W
0x076F	1904	HB01_18[5]	23	0	44		R/W
0x0770	1905	HB01_18[6]	25	0	44		R/W
0x0771	1906	HB01_18[7]	15	0	44		R/W
0x0772	1907	HB01_18[8]	9	0	44		R/W
0x0773	1908	HB01_18[9]	39	0	44		R/W
0x0774	1909	HB01_18[10]	33	0	44		R/W
0x0775	1910	HB01_18[11]	35	0	44		R/W
0x0776	1911	HB01_18[12]	37	0	44		R/W
0x0777	1912	HB01_18[13]	0	0	44		R/W
0x0778	1913	HB01_18[14]	0	0	44		R/W
0x0779	1914	HB01_18[15]	0	0	44		R/W
0x077A	1915	HB01_18[16]	0	0	44		R/W
0x077B	1916	HB01_18[17]	0	0	44		R/W
0x077C	1917	HC01	4	0	9		R/W

0x077D	1918	HC02	6	0	9		R/W
0x077E	1919	HC03	0	0	9		R/W
0x077F	1920	HC04	0	0	9		R/W
0x0780	1921	HC05	0	0	6		R/W
0x0781	1922	HC06	0	0	6		R/W
0x0782	1923	HC07	0	0	9		R/W
0x0783	1924	HC08	0	0	9		R/W
0x0784	1925	HC09	0	0	9		R/W
0x0785	1926	HC10	0	0	9		R/W
0x0786	1927	HC11	0	0	6		R/W
0x0787	1928	HC12	0	0	6		R/W
0x0788	1929	HCF1_Fan_FC_PWM_Freq	1000	10	2000		R/W
0x0789	1930	HCF2_Fan_C1_PWM_Freq	1000	10	2000		R/W
0x078A	1931	HCF3_Fan_C2_PWM_Freq	1000	10	2000		R/W
0x078B	1932	HD01_18[0]	2	0	48		R/W
0x078C	1933	HD01_18[1]	12	0	48		R/W
0x078D	1934	HD01_18[2]	14	0	48		R/W
0x078E	1935	HD01_18[3]	26	0	48		R/W
0x078F	1936	HD01_18[4]	6	0	48		R/W
0x0790	1937	HD01_18[5]	22	0	48		R/W
0x0791	1938	HD01_18[6]	0	0	48		R/W
0x0792	1939	HD01_18[7]	0	0	48		R/W
0x0793	1940	HD01_18[8]	0	0	48		R/W
0x0794	1941	HD01_18[9]	30	0	48		R/W
0x0795	1942	HD01_18[10]	32	0	48		R/W
0x0796	1943	HD01_18[11]	40	0	48		R/W
0x0797	1944	HD01_18[12]	0	0	48		R/W
0x0798	1945	HD01_18[13]	0	0	48		R/W
0x0799	1946	HD01_18[14]	0	0	48		R/W
0x079A	1947	HD01_18[15]	0	0	48		R/W
0x079B	1948	HD01_18[16]	0	0	48		R/W
0x079C	1949	HD01_18[17]	0	0	48		R/W
0x079D	1950	PV01_SHsetpoint1_VC1	6.0	3.0	25.0	°K	R/W
0x079E	1951	PV02_LoSHsetpoint1_VC1	2.0	1.0	3.0	°K	R/W
0x079F	1952	PV03_HiSHsetpoint1_VC1	15.0	10.0	40.0	°K	R/W
0x07A0	1953	PV04_LOPtemp1_VC1	-40.0	-40.0	40.0	°C	R/W
0x07A1	1954	PV05_MOPtemp1_V	40.0	-40.0	40.0	°C	R/W

		C1					
0x07A2	1955	PV06_PIDpropBand 1_VC1	7.0	1.0	100.0	°K	R/W
0x07A3	1956	PV07_PIDintegralTime1_VC1	120	0	999	sec	R/W
0x07A4	1957	PV08_PIDderivTime 1_VC1	120	0	999	sec	R/W
0x07A5	1958	PV09_StartUpDelay 1_VC1	5	1	255	sec	R/W
0x07A6	1959	PV10_StartUpPosition1_VC1	50.0 0	0.00	100.00	%	R/W
0x07A7	1960	PV11_SHsetpoint2_VC1	6.0	3.0	25.0	°K	R/W
0x07A8	1961	PV12_LoSHsetpoint 2_VC1	2.0	1.0	3.0	°K	R/W
0x07A9	1962	PV13_HiSHsetpoint 2_VC1	15.0	10.0	40.0	°K	R/W
0x07AA	1963	PV14_LOTemp2_VC1	- 40.0	-40.0	40.0	°C	R/W
0x07AB	1964	PV15_MOPtemp2_VC1	40.0	-40.0	40.0	°C	R/W
0x07AC	1965	PV16_PIDpropBand 2_VC1	7.0	1.0	100.0	°K	R/W
0x07AD	1966	PV17_PIDintegralTime2_VC1	120	0	999	sec	R/W
0x07AE	1967	PV18_PIDderivTime 2_VC1	120	0	999	sec	R/W
0x07AF	1968	PV19_StartUpDelay 2_VC1	5	1	255	sec	R/W
0x07B0	1969	PV20_StartUpPosition2_VC1	50.0 0	0.00	100.00	%	R/W
0x07B1	1970	PV21_StabilizationDelay_VC1	0	0	255	sec	R/W
0x07B2	1971	PV22_SabilizationPosition_VC1	100. 00	0.00	100.00	%	R/W
0x07B3	1972	PV23_FunctioningMode_VC1	0	0	1	%	R/W
0x07B4	1973	PV24_ManualValvePositionSetPoint_VC1	0.00	0.00	100.00	%	R/W
0x07B5	1974	PV25_SHcontrolParametersSet_VC1	0	0	1	sec	R/W
0x07B6	1975	PV26_RelayFuncSel_VC1	0	0	255	sec	R/W
0x07B7	1976	PV27_AIV3probeType_VC1	0	0	1	0=NTC, 1=PT1000	R/W
0x07B8	1977	PV28_AIV4probeType_VC1	0	0	5	0=4..20mA(0.5-8), 1=4..20mA(0-30), 2=0_5V(0-7), 3=0-5V(0-25), 4=0-5V(0-60), 5=scaling	R/W
0x07B9	1978	PV29_Select_UniversalAIV1_V1	4	1	9	1=PTC, 2=NTC, 3=0-20mA, 4=4-20mA, 5=0-5V, 6=0-10V, 7=PT1000, 8=NTC 10K-2, 9=NTC 10K-3	R/W
0x07BA	1979	PV30_Select_UniversalAIV2_V2	2	1	9	1=PTC, 2=NTC, 3=0-20mA, 4=4-20mA, 5=0-5V, 6=0-10V, 7=PT1000, 8=NTC 10K-2, 9=NTC 10K-3	R/W
0x07BB	1980	PV31_TsTemperatureOffset_VC1	0.0	-10.0	10.0	°K	R/W

0x07BC	1981	PV32_TeTemperatureOffset_VC1	0.0	-10.0	10.0	°K	R/W
0x07BD	1982	PV34_RelayLogic_VC1	0	0	1		R/W
0x07BE	1983	PV35_DI1Logic_VC1	0	0	1		R/W
0x07BF	1984	PV36_DI2Logic_VC1	0	0	1		R/W
0x07C0	1985	PV37_DIHVLogic_VC1	0	0	1		R/W
0x07C1	1986	PV41_SHsetpoint1_VC2	6.0	3.0	25.0	°K	R/W
0x07C2	1987	PV42_LoSHsetpoint1_VC2	2.0	1.0	3.0	°K	R/W
0x07C3	1988	PV43_HiSHsetpoint1_VC2	15.0	10.0	40.0	°K	R/W
0x07C4	1989	PV44_LOPtemp1_VC2	-40.0	-40.0	40.0	°C	R/W
0x07C5	1990	PV45_MOPtemp1_VC2	40.0	-40.0	40.0	°C	R/W
0x07C6	1991	PV46_PIDpropBand1_VC2	7.0	1.0	100.0	°K	R/W
0x07C7	1992	PV47_PIDintegralTime1_VC2	120	0	999	sec	R/W
0x07C8	1993	PV48_PIDderivTime1_VC2	120	0	999	sec	R/W
0x07C9	1994	PV49_StartUpDelay1_VC2	5	1	255	sec	R/W
0x07CA	1995	PV50_StartUpPosition1_VC2	50.0 0	0.00	100.00	%	R/W
0x07CB	1996	PV51_SHsetpoint2_VC2	6.0	3.0	25.0	°K	R/W
0x07CC	1997	PV52_LoSHsetpoint2_VC2	2.0	1.0	3.0	°K	R/W
0x07CD	1998	PV53_HiSHsetpoint2_VC2	15.0	10.0	40.0	°K	R/W
0x07CE	1999	PV54_LOPtemp2_VC2	-40.0	-40.0	40.0	°C	R/W
0x07CF	2000	PV55_MOPtemp2_VC2	40.0	-40.0	40.0	°C	R/W
0x07D0	2001	PV56_PIDpropBand2_VC2	7.0	1.0	100.0	°K	R/W
0x07D1	2002	PV57_PIDintegralTime2_VC2	120	0	999	sec	R/W
0x07D2	2003	PV58_PIDderivTime2_VC2	120	0	999	sec	R/W
0x07D3	2004	PV59_StartUpDelay2_VC2	5	1	255	sec	R/W
0x07D4	2005	PV60_StartUpPosition2_VC2	50.0 0	0.00	100.00	%	R/W
0x07D5	2006	PV61_StabilizationDelay_VC2	0	0	255	sec	R/W
0x07D6	2007	PV62_SabilizationPosition_VC2	100.00	0.00	100.00	%	R/W
0x07D7	2008	PV63_FunctioningM	0	0	1	%	R/W

		ode_VC2					
0x07D8	2009	PV64_ManualValvePositionSetPoint_VC2	0.00	0.00	100.00	%	R/W
0x07D9	2010	PV65_SHcontrolParametersSet_VC2	0	0	1	sec	R/W
0x07DA	2011	PV66_RelayFuncSel_VC2	0	0	255	sec	R/W
0x07DB	2012	PV67_AIV3probeType_VC2	0	0	1	0=NTC, 1=PT1000	R/W
0x07DC	2013	PV68_AIV4probeType_VC2	0	0	5	0=4..20mA(0.5-8), 1=4..20mA(0-30), 2=0_5V(0-7), 3=0-5V(0-25), 4=0-5V(0-60), 5=scaling	R/W
0x07DD	2014	PV69_Select_UniversalAI1_V2	4	1	9	1=PTC, 2=NTC, 3=0-20mA, 4=4-20mA, 5=0-5V, 6=0-10V, 7=PT1000, 8=NTC 10K-2, 9=NTC 10K-3	R/W
0x07DE	2015	PV70_Select_UniversalAIV2_V2	2	1	9	1=PTC, 2=NTC, 3=0-20mA, 4=4-20mA, 5=0-5V, 6=0-10V, 7=PT1000, 8=NTC 10K-2, 9=NTC 10K-3	R/W
0x07DF	2016	PV71_TsTemperatureOffset_VC2	0.0	-10.0	10.0	°K	R/W
0x07E0	2017	PV72_TeTemperatureOffset_VC2	0.0	-10.0	10.0	°K	R/W
0x07E1	2018	PV74_RelayLogic_VC2	0	0	1		R/W
0x07E2	2019	PV75_DI1Logic_VC2	0	0	1		R/W
0x07E3	2020	PV76_DI2Logic_VC2	0	0	1		R/W
0x07E4	2021	PV77_DIHVLogic_VC2	0	0	1		R/W
0x07E5	2022	PV80_enabSHmod_VC1	1	0	1		R/W
0x07E6	2023	PV81_maxSetSH_VC1	15.0	3.0	25.0		R/W
0x07E7	2024	PV82_minSetSH_VC1	2.0	1.0	25.0		R/W
0x07E8	2025	PV83_maxDSH_VC1	35.0	0.0	50.0		R/W
0x07E9	2026	PV84_minDSH_VC1	5.0	0.0	50.0		R/W
0x07EA	2027	PV85_maxSetSH_VC2	15.0	3.0	25.0		R/W
0x07EB	2028	PV86_minSetSH_VC2	2.0	1.0	25.0		R/W
0x07EC	2029	PV87_maxDSH_VC2	35.0	0.0	50.0		R/W
0x07ED	2030	PV88_minDSH_VC2	5.0	0.0	50.0		R/W
0x07EE	2031	PV89_enabSHmod_VC2	1	0	1		R/W

0x07EF	2032	PSd1_Password_User	0	-999	9999	PSd1 - User password	R/W
0x07F0	2033	PSd2_Password_Maintenance	0	-999	9999	PSd2 - Maintain Password	R/W
0x07F1	2034	PSd3_Password_Installation	0	-999	9999	PSd3 - Installer Password	R/W
0x07F2	2035	PSd4_Password_Configuration	0	-999	9999	PSd4 - Costructor Password	R/W

The various statuses/parameters exported by the application are listed below.

**c-pro 3** *micro CHIL*

Programmable controller for single-and two circuits chillers-heat pumps

Application manual ver. 1.0

EB - 41/13

Codice 144CP3CHE104

This document is exclusive property of EVCO. Reproduction and disclosure are prohibited without express authorisation from EVCO.  
EVCO is not liable for any features, technical data and possible errors stated in this document or deriving from use of the same.  
EVCO cannot be considered liable for damage caused by failure to comply with warnings given in this document.  
EVCO reserves the right to make any changes without forewarning, without jeopardising the basic safety and operating feature.



**EVCO S.p.A.**

Via Feltre 81, 32036 SedicoBelluno ITALIA

Tel. 0437/8422 | Fax 0437/83648

info@evco.it | www.evco.it