

## DIMENSIONAL DATA

### OVERALL DIMENSIONS AND PANEL CUTOUT

The dimensions are expressed in millimetres and inches (third-scale drawing).

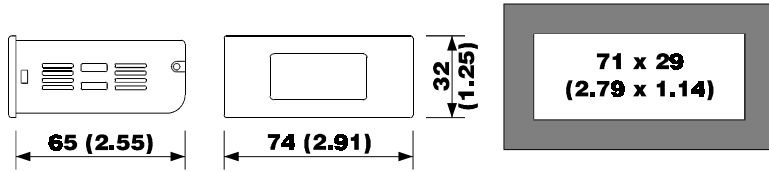

Fig. 3  
ds3ve.wmf

## INSTALLATION

### WITH THE FIXING SYSTEMS SUGGESTED BY THE BUILDER

Panel mounting, with the equipped screw (Fig. 4) or spring brackets (Fig. 5) (third-scale drawing).

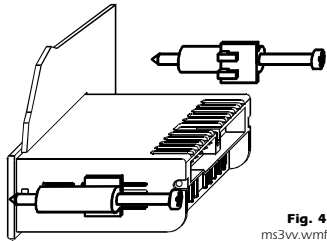

Fig. 4  
ms3vv.wmf

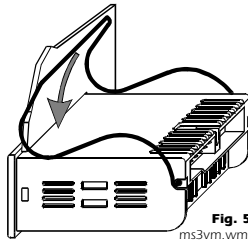

Fig. 5  
ms3vm.wmf

## ELECTRICAL CONNECTION

### CONNECTIONS TO DERIVE

Instance of typical application.

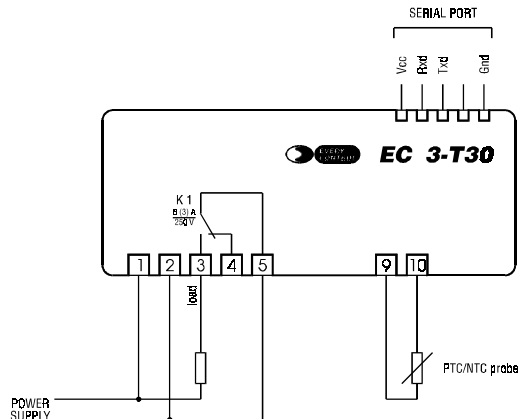

Fig. 6  
c3t30e.wmf

## BUILDER DATA

EVERY CONTROL S.r.l.

Via Mezzaterra 6, 32036 Sedico Belluno ITALY  
Phone 0039/0437852468 (a.r.) Fax 0039/043783648  
Internet addresses  
e-mail: every@worknet.it  
http://www.everycontrol.it

### TO BE CAREFUL

This publication exclusively belongs to EVERY CONTROL and shall not be reproduced and distributed if not expressly authorized by the same EVERY CONTROL. EVERY CONTROL does not assume any responsibility in order to the characteristics, to the technical data and to the possible mistakes related herein or deriving from the use of the same. EVERY CONTROL can not be considered responsible for damages caused from the inobservance of the additional informations. EVERY CONTROL reserves the right to make any modification without prior notice and at any time without prejudice the basic functioning and safety characteristics.

# EC 3-T30

## ON-OFF single output digital thermoregulator supplied from main voltage

Operating instructions

Release 1/98 of November the twelfth 1998

Code EC 3-T30 DOC E000

File 3t30e.p65

**IMPORTANT:**

**The use of this new instrument is easy; but for safety reasons, it is important read these instructions carefully before the installation or before the use and follow all additional informations.**

**It is very important keep these instructions with the instrument for future consultations.**



Fig. 1  
f3-t30.wmf

## GENERAL INFORMATIONS

### WHAT IS THE USE

EC 3-T30 is an ON-OFF single output digital thermoregulator able to cover a temperature range from -50 to +99 °C (-58 to +99 °F); the instrument can be supplied from main voltage (230 Vac) with a very low power consumption (1 VA).

In factory the instrument gets preset to accept at the measure input PTC/NTC probes used in this field of applications at the moment.

Some parameters permit to set the thermoregulator to display the temperature in Fahrenheit or Celsius degrees, for "cooling" or "heating" functioning, to protect the connected load against overloads due to several starts repeated in a short time, to signal working conditions outside the safety limits.

EC 3-T30 is available in the 74 x 32 mm (2.91 x 1.25 in.) case and it is studied for panel mounting with the equipped screw or spring brackets.

## GETTING STARTED

### INSTALLATION

EC 3-T30 was studied for panel mounting, panel cutout 71 x 29 mm (2.79 x 1.14 in.), with the equipped screw or spring brackets (the overall dimensions and the panel cutout are related in Fig. 3, the fixing systems suggested by the builder are related respectively in Fig. 4 and in Fig. 5).

### ADDITIONAL INFORMATIONS

- the panel thickness must be included from 1 to 5 mm (0.04 to 0.19 in.)
- verify if the using conditions (ambient temperature, humidity, etc.) are within the limits indicated by the builder (see the chapter TECHNICAL DATA)
- install the instrument in a location with a suitable ventilation, to avoid the internal overheating of the instrument
- do not install the instrument near surfaces that can obstruct the air-grating (carpets, covers, etc.), heating sources (radiators, hot air ducts, etc.), locations subject to direct sunlight, rain, humidity, excessive dust, mechanical vibrations or bumps, devices with strong magnetos (microwave ovens, big speakers, etc.)
- according with the safety norms, the protection against possible contacts with electrical parts and parts protected with functional insulation only must be ensured through a correct installation procedure of the instrument; all parts that ensure the protection must be fixed so that they can not be removed if not with a tool
- if not differently specified at the time of order, the instrument will be equipped with screw brackets.

### ELECTRICAL CONNECTION

EC 3-T30 is provided with two screw terminal blocks for cables up to 2.5 mm<sup>2</sup> (0.38 in.<sup>2</sup>), for the connection to the power supply, measure input and output) and it is provided with one five poles single line male connector (for the connection to the CLONE configurator/cloner and RICS supervision systems), located on the instrument back panel (the connections to derive are related in Fig. 6 and they are checkable on the polyester label stuck on the instrument case).

### ADDITIONAL INFORMATIONS

- if the instrument is brought from a cold to a warm location, the humidity may condense inside the instrument; wait about an hour before supply the instrument
- verify if the operating power supply voltage, electrical frequency and power of the instrument correspond to the local power supply (see the chapter TECHNICAL DATA)
- do not supply more instruments with the same transformer
- if the instrument is installed on a vehicle, its power supply must be derived directly from the battery of the vehicle
- give the instrument a protection able to limit the current absorbed in case of failure
- the instrument remains connected to the local power supply as long as the terminals 1 and 2 are derived to the local power supply, even if the instrument is apparently turned off
- give the probe a protection able to insulate it against possible contacts with metal parts or use insulated probes

- give the output a protection able to protect it against short circuit and overload
- do not try to repair the instrument; for the repairs apply to highly qualified staff
- if you have any questions or problems concerning the instrument please consult Every Control (see the chapter BUILDER DATA).

## USE

### PRELIMINARY INFORMATIONS

After derived the connections related in Fig. 6, during the normal functioning the instrument displays the temperature read by the probe.

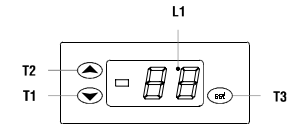

Fig. 2  
iu3130.wmf

If an alarm should be active the instrument displays the alarm code flashing and the buzzer utters an intermittent beep as long as the cause that has given it does not disappear (see the chapter SIGNALS AND ALARMS); pressure on the key T1 during an alarm permits to silence the buzzer.

EC 3-T30 is provided with one working setpoint and with some configuration parameters that get stored in a non volatile memory and that permit to set the instrument according with one's requirements (see the chapter CONFIGURABILITY).

The output K 1 is associated to the working setpoint, it remains activated continuously as long as the temperature read by the probe reaches the working setpoint and when it rises above (if the output was set for "cooling" functioning) or it falls below (if the output was set for "heating" functioning) the working setpoint of the hysteresis value (differential) the output gets reactivated.

### WORKING SETPOINT SETTING (WORKING TEMPERATURE)

To modify the working setpoint value keep pushed the key T3 (the instrument displays the actual value) and at the same time push and release over and over the key T1 or T2 as long as the instrument displays the desired value (keeping pushed the key T1 or T2 the value gets decreased or increased more quickly); after the modification release the key T3 last; during the pressure of the key T3 the LED L1 flashes quickly to indicate that a working setpoint setting procedure is running (to the release of the key T3 the instrument automatically turns out from the working setpoint setting procedure).

### ADDITIONAL INFORMATIONS

- for the whole period of a corrupted memory data alarm the access to the working setpoint setting procedure is refused
- the working setpoint is programmable within the limits established with the parameters r1 and r2
- the working setpoint value gets stored in a non volatile memory even if a lack of power supply happens.

### CONFIGURATION PARAMETERS SETTING

Configuration parameters are arranged on two levels, to protect the most tricky settings against undesirable violations and they are arranged in families that can be recognized through the initial letter of the label.

To gain access to the first level keep pushed at the same time for four seconds at least the keys T1 and T2 (passed four seconds the instrument displays the label PA).

To select a parameter of the first level push and release over and over the key T1 or T2 as long as the instrument displays the label of the desired parameter.

To modify the parameter value keep pushed the key T3 (the instrument displays the actual value) and at the same time push and release over and over the key T1 or T2 as long as the instrument displays the desired value (keeping pushed the key T1 or T2 the value gets decreased or increased more quickly); after the modification release the key T3 last (to the release of the key T3 the instrument displays the label of the parameter again).

To gain access to the second level enter inside the first level and select the label **PA**.

Keep pushed the key **T3** (the instrument displays the actual value) and at the same time push and release over and over the key **T1** or **T2** as long as the instrument displays -19 (keeping pushed the key **T1** or **T2** the value gets decreased or increased more quickly); after the modification release the key **T3** last (to the release of the key **T3** the instrument displays the label **PA** again); keep pushed at the same time for four seconds at least the keys **T1** and **T2** (passed four seconds the instrument displays the first parameter of the second level).

To select a parameter of the second level push and release over and over the key **T1** or **T2** as long as the instrument displays the label of the desired parameter.

To modify the parameter value keep pushed the key **T3** (the instrument displays the actual value) and at the same time push and release over and over the key **T1** or **T2** as long as the instrument displays the desired value (keeping pushed the key **T1** or **T2** the value gets decreased or increased more quickly); after the modification release the key **T3** last (to the release of the key **T3** the instrument displays the label of the parameter again).

To turn out from the configuration parameters setting procedure keep pushed at the same time for four seconds at least the keys **T1** and **T2** or do not operate with the keys for fifty seconds at least (time-out exit).

#### ADDITIONAL INFORMATIONS

- for the whole period of a corrupted memory data alarm the access to the configuration parameters setting procedure is refused
- the modification of a parameter value which unit of measure is the hour or the minute or the second has not immediate effect; to obtain this effect it must not be executed during the course of the value
- the configuration parameters values get stored in a non volatile memory even if a lack of power supply happens.

## CONFIGURABILITY

WORKING SETPOINT				
LABEL MIN.	MAX.	U.M.	ST.	WORKING SETPOINT
r1	r2	(*)	0	working setpoint

It establishes the temperature associated to the output K 1.

CONFIGURATION PARAMETERS				
LABEL MIN.	MAX.	U.M.	ST.	PASSWORD
PA	-55 99	---	0	password (\$)

It is the password that permits to gain access to the second level.

LABEL MIN.	MAX.	U.M.	ST.	MEASURE INPUT
/0	1 3	---	1	kind of probe

It establishes the kind of probe that the instrument must recognize to its measure input, as indicated:

1 =	PTC probe	3 =	NTC probe.
/1	-55 +99 (*)/8	0	calibration (\$)

It establishes a threshold to add algebraically to the signal coming from the measure input (for instance to correct the signal).

/2	0 6	---	3	digital filter
0 =	0 sec.	1 =	0.4 sec.	
2 =	1.2 sec.	3 =	3.0 sec.	
4 =	8.0 sec.	5 =	19.8 sec.	
6 =	48.0 sec.			

/8	0 1	---	1	unit of measure
0 =	the unit of measure is the Fahrenheit degree			
1 =	the unit of measure is the Celsius degree.			

LABELMIN.	MAX.	U.M.	ST.	ON-OFF TEMPERATURE REGULATOR ASSOCIATED TO THE WORKING SETPOINT AND TO THE OUTPUT K 1
r0	-15 +15 (*)	+2	hysteresis (differential) (\$)	

It establishes the hysteresis (differential) relative to the working setpoint.

r1	-55 +99 (*)	-55	minimum working setpoint programmable
It establishes the minimum working setpoint programmable; the instrument automatically verifies if the value established with the parameter r1 is below the maximum working setpoint programmable established with the parameter r2.			

r2	-55 +99 (*)	+99	maximum working setpoint programmable
It establishes the maximum working setpoint programmable; the instrument automatically verifies if the value established with the parameter r2 is above the minimum working setpoint programmable established with the parameter r1.			

r3	0 1	---	0	"cooling" or "heating" functioning
It establishes the output functioning, as indicated:				
0 =	"cooling" functioning			
1 =	"heating" functioning.			

LABEL MIN.	MAX.	U.M.	ST.	OUTPUT K 1 PROTECTION
C0	0 15	min.	0	disabling time to the output activation from the instrument start

It establishes the time that disables the output activation from the moment of the instrument start.

C1	0 15	min.	0	disabling time to the output activation from the previous activation
----	------	------	---	--

It establishes the time that disables the output activation from the moment of the previous output activation.

C2	0 15	min.	0	disabling time to the output activation from the previous deactivation
----	------	------	---	--

It establishes the time that disables the output activation from the moment of the previous output deactivation.

C3	0 1	---	0	output status during a probe failure alarm
It establishes the status to which the output gets forced during a probe failure alarm, as indicated:				
0 =	during a probe failure alarm the output gets forced to the status OFF			
1 =	during a probe failure alarm the output gets forced to the status ON.			

C4	0 1	---	0	disabling time to the output activation and deactivation
It establishes if to disable the output activation and deactivation for a fixed time, as indicated:				
0 =	inactive			
1 =	the output activation and deactivation get disabled for 3 sec.			

LABEL MIN.	MAX.	U.M.	ST.	TEMPERATURE ALARM REGULATOR
A0	+1 +15 (*)	+2	hysteresis (differential)	

It establishes the hysteresis (differential) relative to the parameters A1 and A2.

A1	-55 0	(*)	0	lower alarm set relative to the working setpoint
It establishes a threshold to add algebraically to the working setpoint; the value so obtained establishes the temperature below which the lower temperature alarm gets activated.				
If the parameter A1 has value 0 the lower temperature alarm never gets activated.				

A2	0 +99 (*)	0	upper alarm set relative to the working setpoint
It establishes a threshold to add algebraically to the working setpoint; the value so obtained establishes the temperature above which the upper temperature alarm gets activated.			
If the parameter A2 has value 0 the upper temperature alarm never gets activated.			

A3	0 15	hours	0	disabling time to the alarm activation from the instrument start
----	------	-------	---	--

It establishes the time that disables the temperature alarm activation from the moment of the instrument start.

LABEL MIN.	MAX.	U.M.	ST.	CONNECTION IN A SERIAL NETWORK WITH EVCOBUS PROTOCOL COMMUNICATION
------------	------	------	-----	--

L1	1 15	---	1	instrument address
It establishes the address to which the instrument (slave) answers when it is connected to a serial network with EVCOBUS protocol communication managed from a master (for instance a Personal Computer).				

L2	0 7	---	0	instrument group
It establishes the group to which the instrument (slave) answers when it is connected to a serial network with EVCOBUS protocol communication managed from a master (for instance a Personal Computer).				

#### ADDITIONAL INFORMATIONS

- the symbol (\$) indicates that the parameter is of the first level
- the symbol (\*) indicates that the unit of measure depends from the parameter /8.

## SIGNALS AND ALARMS

#### SIGNALS

If the LED **L1** is turned ON it means that the output K 1 is activated.

If the LED **L1** flashes it means that a count of a disabling time to the output K 1 activation is running (see the parameters C0, C1, C2 and C4).

#### ALARMS

If the instrument displays the indication "E2" flashing and the buzzer utters an intermittent beep (**corrupted memory data alarm**) it means that there is a corruption of the configuration data in the memory (turn OFF and turn ON again the instrument: if to the turning ON again the alarm does not disappear the instrument must be replaced); during this alarm the access to the working setpoint setting and the configuration parameters setting procedures is refused and the output K 1 gets forced to the status OFF.

If the instrument displays the indication "E0" flashing and the buzzer utters an intermittent beep (**probe failure alarm**) it means that: the kind of connected probe is not proper (see the parameter /0), the probe is faulty (verify the probe integrity), there is a mistake in the instrument-probe connection (verify the instrument-probe connection integrity), the temperature read by the probe is outside the limits permitted by the probe in use (verify that the temperature near the probe be inside the limits permitted by the probe); during this alarm the output K 1 gets forced to the status established with the parameter C3.

If the instrument displays the temperature read by the probe flashing and the buzzer utters an intermittent beep (**temperature alarm**) it means that the temperature read by the probe is outside the limit established with the parameter A1 or A2 (see the parameters A0, A1 and A2); inactive.

If the instrument displays the indication "99" flashing (**end of scale display**) it means that the temperature read by the probe is outside the working range permitted by the instrument (verify that the temperature near the probe be inside the limits permitted by the instrument); inactive.

#### ADDITIONAL INFORMATIONS

- the alarm codes are related in order of precedence.

## TECHNICAL DATA

TECHNICAL DATA	
<b>Case:</b>	plastic black (PC-ABS), self-extinguishing.
<b>Size:</b>	74 x 32 x 65 mm (2.91 x 1.25 x 2.55 in.).
<b>Installation:</b>	panel mounting, panel cutout 71 x 29 mm (2.79 x 1.14 in.), with the equipped screw or spring brackets.
<b>Type of protection:</b>	IP 54.
<b>Connections:</b>	screw terminal blocks with pitch 5 mm (0.19 in., power supply, measure input and output) for cables up to 2.5 mm <sup>2</sup> (0.38 in. <sup>2</sup> ), five poles single line male connector with pitch 5.08 mm (0.2 in., serial port).
<b>Ambient temperature:</b>	from 0 to +60 °C (+32 to +140 °F, 10 ... 90 % of not condensing relative humidity).
<b>Power supply:</b>	230 Vac or 115 Vac, 50/60 Hz, 1 VA.
<b>Insulation class:</b>	II.
<b>Alarm buzzer:</b>	incorporated.
<b>Measure inputs:</b>	1 configurable for PTC/NTC probes.

<b>Working range:</b>	from -50 to +99 °C (-58 to +99 °F) for PTC probe, from -40 to +99 °C (-40 to +99 °F) for NTC probe.
<b>Setting range:</b>	from -55 to +99 °C (-55 to +99 °F).
<b>Resolution:</b>	1 °F with unit of measure in Fahrenheit, 1 °C with unit of measure in Celsius.
<b>Display:</b>	2-digit display 12.5 mm (0.49 in.) high red LED display with automatic minus sign, output status indicator.
<b>Outputs:</b>	one change-over contact 8 (3) A @ 250 Vac relay for regulation load management.
<b>Serial port:</b>	TTL with EVCOBUS protocol communication, for the connection to the CLONE configurator/cloner and RICS supervision systems.

## HOW TO ORDER

CODING SYSTEM	
<b>Instrument name:</b>	EC 3-T30.
<b>Desired measure input:</b>	P (for PTC/NTC probes).
<b>Desired power supply:</b>	220 (230 Vac) 115 (115 Vac).
<b>Options:</b>	custom configuration.