

DIMENSIONAL DATA

OVERALL DIMENSIONS AND PANEL CUTOUT

The dimensions are expressed in millimetres and inches (third-scale drawing).

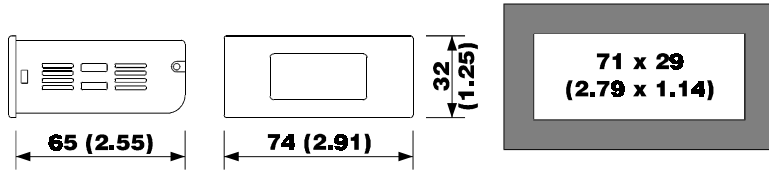

Fig. 3
ds3ve.wmf

INSTALLATION

WITH THE FIXING SYSTEMS SUGGESTED BY THE BUILDER

Panel mounting, with the equipped screw (Fig. 4) or spring brackets (Fig. 5) (third-scale drawing).

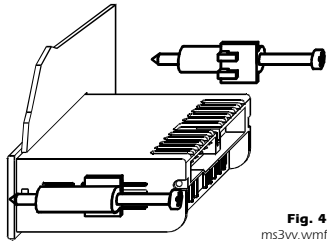

Fig. 4
ms3vv.wmf

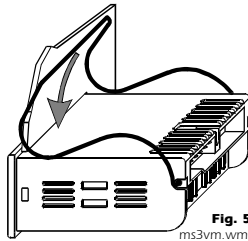

Fig. 5
ms3vm.wmf

ELECTRICAL CONNECTION

CONNECTIONS TO DERIVE

Instance of typical application.

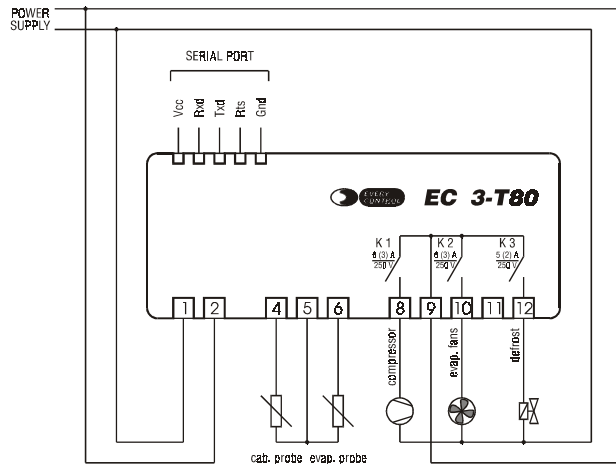

Fig. 6
c3t80e.wmf

BUILDER DATA

EVERY CONTROL S.r.l.

Via Mezzaterra 6, 32036 Sedico Belluno ITALY
Phone 0039/0437852468 (a.r.) Fax 0039/043783648
Internet addresses
e-mail: info@everycontrol.it
http://www.everycontrol.it

TO BE CAREFUL

This publication exclusively belongs to EVERY CONTROL and shall not be reproduced and distributed if not expressly authorized by the same EVERY CONTROL.
EVERY CONTROL does not assume any responsibility in order to the characteristics, to the technical data and to the possible mistakes related herein or deriving from the use of the same.
EVERY CONTROL can not be considered responsible for damages caused from the inobservance of the additional informations.
EVERY CONTROL reserves the right to make any modification without prior notice and at any time without prejudice the basic functioning and safety characteristics.

EC 3-T80

ON-OFF digital thermostat for compressor, evaporator fans and defrost (for temperature-time) management supplied from main voltage

Operating instructions

Release 3/00 of June the twenty-first 2000

Code EC 3-T80 DOC E002

File 3t80e.p65

IMPORTANT:

The use of this new instrument is easy; but for safety reasons, it is important read these instructions carefully before the installation or before the use and follow all additional informations.

It is very important keep these instructions with the instrument for future consultations.



Fig. 1
f3-t80.wmf

GENERAL INFORMATIONS

WHAT IS THE USE

EC 3-T80 is an ON-OFF digital thermostat studied for refrigerating systems management through the compressor, evaporator fans and defrost (for temperature-time) management; the instrument can be supplied from main voltage (230 Vac).

In factory the instrument gets preset to accept at the measure inputs PTC/NTC probes used in refrigeration field at the moment.

Some parameters permit to set the thermostat to protect the compressor against overloads due to several starts repeated in a short time, to manage the defrost according with one's requirements, to establish the evaporator fans output functioning, to signal working conditions outside the safety limits.

EC 3-T80 is available in the 74 x 32 mm (2.91 x 1.25 in.) case and it is studied for panel mounting with the equipped screw or spring brackets.

GETTING STARTED

INSTALLATION

EC 3-T80 was studied for panel mounting, panel cutout 71 x 29 mm (2.79 x 1.14 in.), with the equipped screw or spring brackets (the overall dimensions and the panel cutout are related in Fig. 3, the fixing systems suggested by the builder are related respectively in Fig. 4 and in Fig. 5).

ADDITIONAL INFORMATIONS

- the panel thickness must be included from 1 to 5 mm (0.04 to 0.19 in.)
- verify if the using conditions (ambient temperature, humidity, etc.) are within the limits indicated by the builder (see the chapter TECHNICAL DATA)
- install the instrument in a location with a suitable ventilation, to avoid the internal overheating of the instrument
- do not install the instrument near surfaces that can to obstruct the air-grating (carpets, covers, etc.), heating sources (radiators, hot air ducts, etc.), locations subject to direct sunlight, rain, humidity, excessive dust, mechanical vibrations or bumps, devices with strong magnets (microwave ovens, big speakers, etc.)
- according with the safety norms, the protection against possible contacts with electrical parts and parts protected with functional insulation only must be ensured through a correct installation procedure of the instrument; all parts that ensure the protection must be fixed so that they can not be removed if not with a tool
- if not differently specified at the time of order, the instrument will be equipped with screw brackets.

ELECTRICAL CONNECTION

EC 3-T80 is provided with three screw terminal blocks for cables up to 2.5 mm² (0.38 in.², for the connection to the power supply, measure inputs and outputs) and it is provided with one five poles single line male connector (for the connection to the CLONE configurator/cloner and RICS supervision systems), located on the instrument back panel (the connections to derive are related in Fig. 6 and they are checkable on the polyester label stuck on the instrument case).

ADDITIONAL INFORMATIONS

- if the instrument is brought from a cold to a warm location, the humidity may condense inside the instrument; wait about an hour before supply the instrument
- verify if the operating power supply voltage, electrical frequency and power of the instrument correspond to the local power supply (see the chapter TECHNICAL DATA)
- do not supply more instruments with the same transformer
- if the instrument is installed on a vehicle, its power supply must be derived directly from the battery of the vehicle
- give the instrument a protection able to limit the current absorbed in case of failure
- the instrument remains connected to the local power supply as long as the terminals 1 and 2 are derived to the local power supply, even if the instrument is apparently turned off

- give the probes a protection able to insulate them against possible contacts with metal parts or use insulated probes
- give the outputs a protection able to protect them against short circuit and overload
- do not try to repair the instrument; for the repairs apply to highly qualified staff
- if you have any questions or problems concerning the instrument please consult Every Control (see the chapter BUILDER DATA).

USE

PRELIMINARY INFORMATIONS

After derived the connections related in Fig. 6, during the normal functioning the instrument displays the temperature read by the cabinet probe.

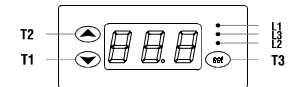

Fig. 2
iu3195.wmf

If an alarm should be active the instrument displays the alarm code flashing as long as the cause that has given it does not disappear (see the chapter SIGNALS AND ALARMS).

EC 3-T80 is provided with one working setpoint and with some configuration parameters that get stored in a non volatile memory and that permit to set the instrument according with one's requirements (see the chapter CONFIGURABILITY).

The output K 1 is associated to the compressor and to the working setpoint, it remains activated continuously as long as the temperature read by the cabinet probe reaches the working setpoint and when it rises above the working setpoint of the hysteresis value (differential) the output gets reactivated, except during a defrost and a dripping.

The output K 2 is associated to the evaporator fans and it is forced to the status ON, except during a dripping and except what established with the parameters of the family F.

Passed the defrost interval from the moment of the instrument start or from the moment in which the instrument presents a request of a defrost cycle, if the conditions permit it (the temperature read by the evaporator probe must be below the defrost stopping setpoint) the instrument automatically presents the following request of a defrost cycle.

A defrost cycle provides three phases (defrost, dripping and evaporator fans stoppage) connected in cascade since the end of one automatically determines the passage to the following one.

The output K 3 is associated to the defrost and it remains continuously activated during the defrost as long as the temperature read by the evaporator probe reaches the defrost stopping setpoint when the defrost ends and the instrument automatically moves to the dripping; if the instrument was set to manage defrost to resistances (electrical) during a defrost the output K 1 gets forced to the status OFF, if the instrument was set to manage hot gas defrost (reversal of cycle) during a defrost the output K 1 remains continuously activated.

Passed the dripping length from the moment of the defrost end the instrument automatically moves to the evaporator fans stoppage; during a dripping the outputs K 1 and K 2 get forced to the status OFF.

Passed the evaporator fans stoppage length from the moment of the dripping end the defrost cycle ends; during an evaporator fans stoppage the output K 2 activation gets disabled.

If the conditions permit it (the temperature read by the evaporator probe must be below the defrost stopping setpoint) keeping pushed the key T2 for four seconds at least the instrument presents a request of a defrost cycle.

WORKING SETPOINT SETTING (WORKING TEMPERATURE)

To modify the working setpoint value keep pushed the key T3 (the instrument displays the actual value) and at the same time push and release over and over the key T1 or T2 as long as the instrument displays the desired value (keeping pushed the key T1 or T2 the value gets decreased or increased more quickly); after the modification release the key T3 last; during the pressure of the key T3 the LED L1 flashes quickly to indicate that a working setpoint setting procedure is running (to the release of the key T3 the instrument automatically turns out from

the working setpoint setting procedure).

ADDITIONAL INFORMATIONS

- *for the whole period of a corrupted memory data alarm the access to the working setpoint setting procedure is refused*
- *the working setpoint is programmable within the limits established with the parameters r1 and r2*
- *the working setpoint value gets stored in a non volatile memory even if a lack of power supply happens.*

CONFIGURATION PARAMETERS SETTING

Configuration parameters are arranged on two levels, to protect the most tricky settings against undesirable violations and they are arranged in families that can be recognized through the initial letter of the label.

To gain access to the first level keep pushed at the same time for four seconds at least the keys **T1** and **T2** (passed four seconds the instrument displays the label **PA**).

To select a parameter of the first level push and release over and over the key **T1** or **T2** as long as the instrument displays the label of the desired parameter.

To modify the parameter value keep pushed the key **T3** (the instrument displays the actual value) and at the same time push and release over and over the key **T1** or **T2** as long as the instrument displays the desired value (keeping pushed the key **T1** or **T2** the value gets decreased or increased more quickly); after the modification release the key **T3** last (to the release of the key **T3** the instrument displays the label of the parameter again).

To gain access to the second level enter inside the first level and select the label **PA**.

Keep pushed the key **T3** (the instrument displays the actual value) and at the same time push and release over and over the key **T1** or **T2** as long as the instrument displays -19 (keeping pushed the key **T1** or **T2** the value gets decreased or increased more quickly); after the modification release the key **T3** last (to the release of the key **T3** the instrument displays the label **PA** again); keep pushed at the same time for four seconds at least the keys **T1** and **T2** (passed four seconds the instrument displays the first parameter of the second level).

To select a parameter of the second level push and release over and over the key **T1** or **T2** as long as the instrument displays the label of the desired parameter.

To modify the parameter value keep pushed the key **T3** (the instrument displays the actual value) and at the same time push and release over and over the key **T1** or **T2** as long as the instrument displays the desired value (keeping pushed the key **T1** or **T2** the value gets decreased or increased more quickly); after the modification release the key **T3** last (to the release of the key **T3** the instrument displays the label of the parameter again).

To turn out from the configuration parameters setting procedure keep pushed at the same time for four seconds at least the keys **T1** and **T2** or do not operate with the keys for fifty seconds at least (time-out exit).

ADDITIONAL INFORMATIONS

- *for the whole period of a corrupted memory data alarm the access to the configuration parameters setting procedure is refused*
- *the modification of a parameter value which unit of measure is the hour or the minute or the second has not immediate effect; to obtain this effect it must not be executed during the course of the value*
- *the configuration parameters values get stored in a non volatile memory even if a lack of power supply happens.*

CONFIGURABILITY

WORKING SETPOINT

LABEL MIN.	MAX.	U.M.	ST.	WORKING SETPOINT
r1	r2	°C	+2	working setpoint

It establishes the temperature associated to the output K 1.

CONFIGURATION PARAMETERS

LABEL MIN.	MAX.	U.M.	ST.	PASSWORD	
PA	-55	99	---	0	password (\$)

It is the password that permits to gain access to the second level.

LABEL MIN.	MAX.	U.M.	ST.	MEASURE INPUTS	
/0	1	4	---	1	kind of probe

It establishes the kind of probe that the instrument must recognize to its measure inputs, as indicated:

1 = PTC probe 2 = reserved
3 = NTC probe 4 = reserved.

/1 -55 +99 °C/0 0 calibration

It establishes a threshold to add algebraically to the signals coming from the measure inputs (for instance to correct the signals).

/2 0 6 --- 3 digital filter

It establishes a time constant to apply to the signals coming from the measure inputs, as indicated:

0 = 0 sec. 1 = 0.4 sec.
2 = 1.2 sec. 3 = 3.0 sec.
4 = 8.0 sec. 5 = 19.8 sec.
6 = 48.0 sec.

/3 --- --- --- --- reserved

Reserved.

LABEL MIN.	MAX.	U.M.	ST.	ON-OFF TEMPERATURE REGULATOR ASSOCIATED TO THE WORKING SETPOINT AND TO THE OUTPUT K 1	
r0	+1	+15	°C	+2	hysteresis (differential) (\$)

It establishes the hysteresis (differential) relative to the working setpoint.

r1 -55 +99 °C -50 minimum working setpoint programmable

It establishes the minimum working setpoint programmable; the instrument automatically verifies if the value established with the parameter r1 is below the maximum working setpoint programmable established with the parameter r2.

r2 -55 +99 °C +50 maximum working setpoint programmable

It establishes the maximum working setpoint programmable; the instrument automatically verifies if the value established with the parameter r2 is above the minimum working setpoint programmable established with the parameter r1.

LABEL MIN.	MAX.	U.M.	ST.	OUTPUT K 1 PROTECTION	
C0	0	15	min.	0	disabling time to the output activation from the instrument start

It establishes the time that disables the output activation from the moment of the instrument start.

C1	0	15	min.	5	disabling time to the output activation from the previous activation
----	---	----	------	---	--

It establishes the time that disables the output activation from the moment of the previous output activation.

C2	0	15	min.	3	disabling time to the output activation from the previous deactivation
----	---	----	------	---	--

It establishes the time that disables the output activation from the moment of the previous output deactivation.

C3 0 1 --- 0 output status during a cabinet probe failure alarm

It establishes the status to which the output gets forced during a cabinet probe failure alarm, as indicated:

0 = during a cabinet probe failure alarm the output gets forced to the status OFF
1 = during a cabinet probe failure alarm the output gets forced to the status ON.

C4 0 1 --- 0 disabling time to the output activation and deactivation

It establishes if to disable the output activation and deactivation for a fixed time, as indicated:

0 = inactive

1 = the output activation and deactivation get disabled for 3 sec.

LABEL MIN.	MAX.	U.M.	ST.	DEFROST REGULATOR	
d0	0	99	(*)	8	defrost interval

It establishes the time interval that pass from the moment of the instrument start or from the moment in which the instrument presents a request of a defrost cycle to the moment in which the instrument automatically presents the following request of a defrost cycle.

If the parameter d0 has value 0 the instrument never automatically presents a request of a defrost cycle, except what established with the parameter d4.

d1 0 1 --- 0 kind of defrost

It establishes the kind of defrost that the instrument must manage, as indicated:

0 = to resistances (electrical)

1 = to hot gas (reversal of cycle).

d2 -55 +99 °C +2 defrost stopping setpoint

It establishes the temperature to which a defrost gets stopped and it is referred to the evaporator probe.

d3 1 99 (*) 30 defrost maximum length

It establishes the defrost maximum length.

Passed the defrost maximum length from the moment in which the instrument activates a defrost cycle, if the temperature read by the evaporator probe is below the setpoint established with the parameter d2 the defrost ends.

d4 0 1 --- 0 defrost cycle at the instrument start

It establishes if the instrument automatically must present a request of a defrost cycle at the moment of the instrument start, as indicated:

0 = inactive

1 = the instrument automatically presents a request of a defrost cycle at the moment of the instrument start.

d5	0	99	(*)	0	delay to a defrost cycle activation from the instrument start
----	---	----	-----	---	---

If the parameter d4 has value 0 it establishes a time interval to add to the interval established with the parameter d0; the value so obtained establishes the time interval that pass from the moment of the instrument start to the moment in which the instrument automatically presents the following request of a defrost cycle.

If the parameter d4 has value 1 it establishes the delay with which the instrument automatically presents a request of a defrost cycle from the moment of the instrument start.

A manual presentation of a request of a defrost cycle during the count of the delay established with the parameter d5 clears the delay.

d6	0	1	---	1	locking of the displayed temperature from a defrost cycle activation
----	---	---	-----	---	--

It establishes if to lock the displayed temperature from the moment in which the instrument activates a defrost cycle, as indicated:

0 = inactive

1 = during a defrost, a dripping and as long as the temperature read by the cabinet probe reaches the working setpoint, the instrument displays the temperature read by the cabinet probe in the moment in which the instrument activates a defrost cycle.

d7 0 15 (*) 2 dripping length

It establishes the dripping length.

d8	0	15	hours	1	disabling time to the temperature alarm activation from the defrost cycle end
----	---	----	-------	---	---

It is significant exclusively if the parameter db has value 0, it establishes the time that disables the temperature alarm activation from the moment of the defrost cycle end.

d9 0 1 --- 0 disabling times to the output K 1 activation override

It is significant exclusively if the parameter d1 has value 1, it establishes if to clear the disabling times to the output K 1 activation in the moment in which the instrument presents a request of a defrost cycle, as indicated:

0 = inactive

1 = in the moment in which the instrument presents a request of a defrost cycle the disabling times to the output K 1 activation get cleared.

dA --- --- °C --- evaporator probe reading (\$)

It permits to display the temperature read by the evaporator probe.

dB 0 1 --- 0 times base for the parameters d0, d3, d5, d7 and F5

It establishes the unit of measure of the parameters d0, d3, d5, d7 and F5, as indicated:

0 = the unit of measure of the parameter d0 is the hour and the unit of measure of the parameters d3, d5, d7 and F5 is the minute

1 = the unit of measure of the parameter d0 is the minute and the unit of measure of the parameters d3, d5, d7 and F5 is the second.

LABEL MIN.	MAX.	U.M.	ST.	TEMPERATURE ALARM REGULATOR	
A0	+1	+15	°C	+2	hysteresis (differential)

It establishes the hysteresis (differential) relative to the parameters A1 and A2.

A1 -55 0 °C -10 lower alarm set relative to the working setpoint

It establishes a threshold to add algebraically to the working setpoint; the value so obtained establishes the temperature below which the lower temperature alarm gets activated and it is referred to the cabinet probe.

If the parameter A1 has value 0 the lower temperature alarm never gets activated.

A2 0 +99 °C +10 upper alarm set relative to the working setpoint

It establishes a threshold to add algebraically to the working setpoint; the value so obtained establishes the temperature above which the upper temperature alarm gets activated and it is referred to the cabinet probe.

If the parameter A2 has value 0 the upper temperature alarm never gets activated.

A3	0	15	hours	2	disabling time to the alarm activation from the instrument start
----	---	----	-------	---	--

It establishes the time that disables the temperature alarm activation from the moment of the instrument start.

A4 --- --- --- --- reserved

Reserved.

LABEL MIN.	MAX.	U.M.	ST.	EVAPORATOR FANS REGULATOR ASSOCIATED TO THE OUTPUT K 2	
F0	0	1	---	1	output functioning

It establishes the output functioning, as indicated:

0 = the output is associated to the setpoint established with the parameter F1, it remains continuously activated as long as the temperature read by the evaporator probe reaches the setpoint established with the parameter F1 and when it falls below the setpoint established with the parameter F1 of the hysteresis value (differential) established with the parameter F2 the output gets reactivated, except what established with the parameters d7, F3, F4 and F5

1 = the output gets forced to the status ON, except what established with the parameters d7, F3, F4 and F5.

F1 -55 +99 °C -1 output deactivation setpoint

It is significant exclusively if the parameter F0 has value 0, according with the modality established with the parameter F6, it establishes the temperature to which the output gets deactivated and it is referred to the evaporator probe.

F2 +2 +15 °C +2 hysteresis (differential)

It is significant exclusively if the parameter F0 has value 0, it establishes the hysteresis (differential) relative to the parameter F1.

F3 0 1 --- 1 output typology

It establishes a bond with the output K 1 status, as indicated:

0 = inactive

1 = during the status OFF of the output K 1 the output gets forced to the status OFF.

F4 0 1 --- 1 output forced to the status OFF during the defrost

It establishes if to force the output to the status OFF during a defrost, as indicated:

0 = inactive

1 = during a defrost the output gets forced to the status OFF.

F5 0 15 (*) 15 evaporator fans stoppage length

It establishes the evaporator fans stoppage length.

F6 0 1 --- 0 kind of output deactivation setpoint

It is significant exclusively if the parameter F0 has value 0, it establishes the kind of output deactivation setpoint that the instrument must manage, as indicated:

0 = absolute (the output deactivation setpoint establishes the temperature to which the output gets deactivated)

1 = relative to the temperature read by the cabinet probe (the value obtained subtracting the absolute value of the output deactivation setpoint to the temperature read by the cabinet probe establishes the temperature to which the output gets deactivated).

LABEL MIN.	MAX.	U.M.	ST.	CONNECTION IN A SERIAL NETWORK WITH EVCOBUS PROTOCOL COMMUNICATION	
L0	---	---	---	---	reserved

Reserved.

L1	1	15	---	1	instrument address
----	---	----	-----	---	--------------------

It establishes the address to which the instrument (slave) answers when it is connected to a serial network with EVCOBUS protocol communication managed from a master (for instance a Personal Computer).

ADDITIONAL INFORMATIONS

- *the symbol (\$) indicates that the parameter is of the first level*

- *the symbol (*) indicates that the unit of measure depends from the parameter db.*

SIGNALS AND ALARMS

SIGNALS

If the LED L1 is turned ON it means that the output K 1 is activated.

If the LED L2 is turned ON it means that the output K 3 is activated.

If the LED L3 is turned ON it means that the output K 2 is activated.

If the LED L1 flashes it means that a count of a disabling time to the output K 1 activation is running (see the parameters C0, C1, C2 and C4).

If the LED L2 flashes it means that a count of a delay time to a defrost cycle activation is running (see the parameters C0, C1, C2 and C4) or that a dripping is running (see the parameter d7).

If the LED L3 flashes it means that an evaporator fans stoppage is running (see the parameter

F5).

ALARMS

If the instrument displays the indication "E2" flashing (**corrupted memory data alarm**) it means that there is a corruption of the configuration data in the memory (turn OFF and turn ON again the instrument: if to the turning ON again the alarm does not disappear the instrument must be replaced); during this alarm the access to the working setpoint setting and the configuration parameters setting procedures is refused and all outputs get forced to the status OFF.

If the instrument displays the indication "E0" flashing (**cabinet probe failure alarm**) it means that: the kind of connected cabinet probe is not proper (see the parameter /0), the cabinet probe is faulty (verify the cabinet probe integrity), there is a mistake in the instrument-cabinet probe connection (verify the instrument-cabinet probe connection integrity), the temperature read by the cabinet probe is outside the limits permitted by the cabinet probe in use (verify that the temperature near the cabinet probe be inside the limits permitted by the cabinet probe); during this alarm the output K 1 gets forced to the status established with the parameter C3, if a defrost cycle is running the defrost cycle ends and the instrument never activates a defrost cycle.

If the instrument displays the indication "E1" flashing (**evaporator probe failure alarm**) it means that there is one of the faults saw in the previous case but referred to the evaporator probe; during this alarm, if the parameter F0 has value 0 the output K 2 gets forced to the same status of the output K 1, if the parameter F0 has value 1 the output K 2 remains continuously activated, except what established with the parameters d7, F3, F4 and F5 and the defrost ends passed the defrost maximum length.

If the instrument displays the temperature read by the cabinet probe flashing (**temperature alarm**) it means that the temperature read by the cabinet probe is outside the limit established with the parameter A1 or A2 (see the parameters A0, A1 and A2); inactive.

ADDITIONAL INFORMATIONS

- *if the parameter F0 has value 1 during an evaporator fans stoppage the LEDL3 does not flashe*

- *the alarm codes are related in order of precedence*

- *during a defrost cycle the temperature alarm is disabled.*

TECHNICAL DATA

TECHNICAL DATA

Case:	plastic black (PC-ABS), self-extinguishing.
Size:	74 x 32 x 65 mm (2,91 x 1,25 x 2,55 in.).
Installation:	panel mounting, panel cutout 71 x 29 mm (2,79 x 1,14 in.), with the equipped screw or spring brackets.
Type of protection:	IP 54.
Connections:	screw terminal blocks with pitch 5 mm (0.19 in., power supply, measure inputs and outputs) for cables up to 2.5 mm ² (0.38 in. ²), five poles single line male connector with pitch 5.08 mm (0.2 in., serial port).

Ambient temperature: from 0 to +50 °C (+32 to +122 °F, 10 ... 90 % of not condensing relative humidity).

230 Vac or 115 Vac, 50/60 Hz, 1.5 VA.

II.

Power supply: 2 (cabinet and evaporator probe) configurable for PTC/NTC probes.

Working range: from -50 to +150 °C (-58 to +199 °F) for PTC probe, from -40 to +110 °C (-40 to +199 °F) for NTC probe.

Setting range: from -55 to +99 °C (-55 to +99 °F).

Resolution: 1 °C (1 °F).

Display: 3-digit display 12,5 mm (0,49 in.) high red LED display with automatic minus sign, output status indicators.

Outputs: three NO contact relays of which two 6 (3) A @ 250 Vac relays for one ½ HP @ 250 Vac compressor and for evaporator fans management and one 5 (2) A @ 250 Vac relay for defrost system management.

Kind of defrost managed: to resistances (electrical) and to hot gas (reversal of cycle), automatic and manual.

Defrost management: for interval, stopping temperature and maximum length.

Serial port: TTL with EVCOBUS protocol communication, for the connection to the CLONE configur/cloner and RICS supervison systems.

HOW TO ORDER

CODING SYSTEM

Instrument name: EC 3-T80.

Desired measure input: P (for PTC/NTC probes).

Desired power supply: 220 (230 Vac), 110 (115 Vac).

Options: custom configuration, presetting to accept at the measure inputs Pt 1000 probes, temperature display in °F.