



Applications



Refrigeration units



Chiller



Display cabinets

c-pro 3 OEM

Hardware manual:

[Programmable controls](#)

- | Flexible, modular, expandable
- | 21 inputs and outputs
- | Variety of communications ports
- | Models with management of Pulse electronic expansion valves
- | Models with integrates user interface or in blind version
- | Standard 8 DIN module format
- | OEM oriented



IMPORTANT

Read this document thoroughly before installation and before use of the device and follow all recommendations; keep this document with the device for future consultation.
Only use the device in the way described in this document; do not use the same as a safety device



CONSIDER THE ENVIRONMENT

Please read carefully and save this document



DISPOSAL

The device must be disposed of in compliance with local standards regarding the collection of electric and electronic equipment

Index

Introduction	6
Purchasing codes	7
Open frame version	7
Purchasing codes	8
Plastic housing version (blind/LCD)	8
Dimensions	9
Open frame version	9
Plastic housing version (blind)	9
Plastic housing version (LCD)	9
Installation	10
Open frame version	10
Plastic housing version (blind/LCD)	10
Electrical connections	11
Connectors description	11
Open frame version	11
Plastic housing version (blind/LCD)	13
Electrical connection	15
Open frame version	15
Termination of the RS-485 MODBUS and CAN networks. Polarisation of RS-485 MODBUS network	15
Plastic housing version (blind/LCD)	16
Termination of the RS-485 MODBUS and CAN networks. Polarisation of RS-485 MODBUS network	16
User interface version configuration	17
Keyboard	17
Key description	17
Switching ON/OFF the device	17
Accessing the procedure	17
Accessing the menu	17
Parameters configuration	17
Password	17

 Housing and blind version configuration	18
Through a controller with user interface	18
Configuration	18
Switching ON/OFF the device	18
Accessing the procedure from c-pro 3 OEM LCD	18
CAN node address setting	18
Accessing the menu from c-pro 3 OEM LCD	19
Parameters configuration from c-pro 3 OEM LCD	19
Password	19
Through a remote user interface	20
Configuration	20
Key description	20
Switching ON/OFF the device from EPJgraph	20
Accessing the procedure from EPJgraph	20
Password	20
CAN node address setting	21
Accessing the menu from EPJgraph	21
Parameters configuration from EPJgraph	21
 LED	22
LED description	22
 Settings menu	23
Keys description and parameters settings	23
Menu "Info" keys	23
Menu "Info" parameters	23
Menu "Languages" keys	24
Menu "Languages" parameters	24
Menu "Parameters" keys	25
Menu "Parameters (1)" parameters	25
Menu "Parameters (2)" parameters	26
Menu "Networks" keys	27
Menu "Networks" - Submenu "CAN Bus" parameters	27
Menu "Networks" - Submenu "UART1" parameters	28
Menu "Networks" - Submenu "UART2" parameters	29
Menu "Networks" - Submenu "USB" parameters	29
Menu "Password" keys	30
Menu "Password" parameters	30
Menu "Backup/Restore" keys	31
Menu "Backup/Restore" parameters	31

 Accessories	32
Connection cables	32
0810500018/0810500020	32
USB flash drive	32
EVUSB4096M	32
RS-485/USB serial interface	32
EVIF20SUXI	32
INTRABUS/RS-485 serial interface	32
EVIF22ISX	32
Phase cutting speed regulator	33
EVDFAN1	33
Connection kit	33
CJAV45	33
 Technical data	34

Introduction

c-pro 3 OEM is a range of programmable controllers in 8-DIN modules, open-board or with housing (blind or with built-in LCD display). It has numerous inputs and outputs (up to 21) and an enhanced memory capacity to meet the management needs of the HVAC/R sector and OEM companies in particular. The models with Pulse outputs, for example, can be used to control multiplexed cabinets.

Thanks to the INTRABUS protocol, advantageous point-to-point solutions can be used, including the possibility of connecting to remote LED (**Vled 3**) or LCD (**EVJ LCD**) user interfaces.

The CAN protocol makes it possible to increase the number of **c-pro 3 OEM** inputs/outputs by adding an expansion and to be integrated with the entire range of **c-pro 3 controllers** and displays.

The MODBUS RTU option, used with an external interface, is always available in both master and slave modes. Those models supplied with the RS-485 enable two MODBUS protocols to be used at the same time.

The application software can be designed in a simple, intuitive and portable way thanks to the **UNI-PRO 3** integrated development environment. The USB port, supplied as standard, makes the controller easy to program in the development phase and in debugging and it can be updated using the most common USB flash drives.



Purchasing codes

Open frame version

The following table shows the available **c-pro 3 OEM** models, open frame version, and the relative purchasing codes

Features	Models		
	EPB90	EPB90R	EPB90V
Power supply			
115... 230 VAC	•	•	•
Configurable inputs (analogue or digital)			
Analogue input (PTC/NTC/Pt 1000) or digital input (dry contact)	4	4	4
Analogue input (NTC/0-5 V ratiometric/0-10 V/0-20 mA/4-20 mA) or digital input (dry contact)	3	3	3
Digital inputs			
Dry contact and for pulse trains up to 2 KHz	2	2	2
High voltage	2	2	3
Analogue outputs			
0-10 V/PWM	4	4	4
Digital outputs (electro-mechanical relays; A res. at 250 VAC)			
5 A SPST	4	4	4
8 A SPST	1	1	1
16 A SPDT	1	1	1
Digital outputs (Pulse)			
230 VAC max. 30 W			1
User interface			
None (open frame)	•	•	•
Format			
8 DIN modules	•	•	•
Installation mode			
DIN guide	•	•	•
Connections			
Screw terminal blocks	•	•	•
Type A female USB connector	•	•	•
Communication ports			
INTRABUS	1	1	1
RS-485 MODBUS MASTER/SLAVE		1	1
CAN	1	1	1
USB	1	1	1
Other Features			
Real Time Clock		•	•

For further informations look at chapter "Technical data"

Purchasing codes description

Features	Codes
115... 230 VAC - Open frame version - 8 DIN modules - DIN guide- INTRABUS - CAN - USB	EPB90
115... 230 VAC - Open frame version - 8 DIN modules - DIN guide - INTRABUS - RS-485 - CAN - USB - Real Time Clock	EPB90R
115... 230 VAC - Open frame version - 8 DIN modules - DIN guide - Digital output Pulse - INTRABUS - RS-485 - CAN - USB - Real Time Clock	EPB90V

Purchasing codes

Plastic housing version (blind/LCD)

The following table shows the available **c-pro 3 OEM** models, plastic housing version (blind/LCD), and the relative purchasing codes

Features	Models			
	EPB9BXE	EPB9BRE	EPB9BVE	EPB9DRE
Power supply				
115... 230 VAC	•	•	•	•
Configurable inputs (analogue or digital)				
Analogue input (PTC/NTC/Pt 1000) or digital input (dry contact)	4	4	4	4
Analogue input (NTC/0-5 V ratiometric/0-10 V/0-20 mA/4-20 mA) or digital input (dry contact)	3	3	3	3
Digital inputs				
Dry contact and for pulse trains up to 2 KHz	2	2	2	2
High voltage	2	2	3	2
Analogue outputs				
0-10 V/PWM	4	4	4	4
Digital outputs (electro-mechanical relays; A res. at 250 VAC)				
5 A SPST	4	4	4	4
8 A SPST	1	1	1	1
16 A SPDT	1	1	1	1
Digital outputs (Pulse)				
230 VAC max. 30 W			1	
User interface				
None (blind controller)	•	•	•	
6 buttons + LCD Display				•
Format				
8 DIN modules	•	•	•	•
Installation mode				
DIN guide	•	•	•	•
Connections				
Plug-in screw terminal blocks	•	•	•	•
Type A female USB connector	•	•	•	•
Communication ports				
INTRABUS	1	1	1	1
RS-485 MODBUS MASTER/SLAVE		1	1	1
CAN	1	1	1	1
USB	1	1	1	1
Other Features				
Real Time Clock		•	•	•

For further informations look at chapter "Technical data"

Purchasing codes description

Features	Codes
115... 230 VAC - Plastic housing version (blind) - 8 DIN modules - DIN guide - INTRABUS - CAN - USB	EPB9BXE
115... 230 VAC - Plastic housing version (blind) - 8 DIN modules - DIN guide - INTRABUS - RS-485 - CAN - USB - Real Time Clock	EPB9BRE
115... 230 VAC - Plastic housing version (blind) - 8 DIN modules - DIN guide - INTRABUS - RS-485 - CAN - USB - Real Time Clock	EPB9BVE
115... 230 VAC - Plastic housing version (LCD) - 8 DIN modules - DIN guide - Digital output Pulse - INTRABUS - RS-485 - CAN - USB - Real Time Clock	EPB9DRE

Dimensions

Open frame version

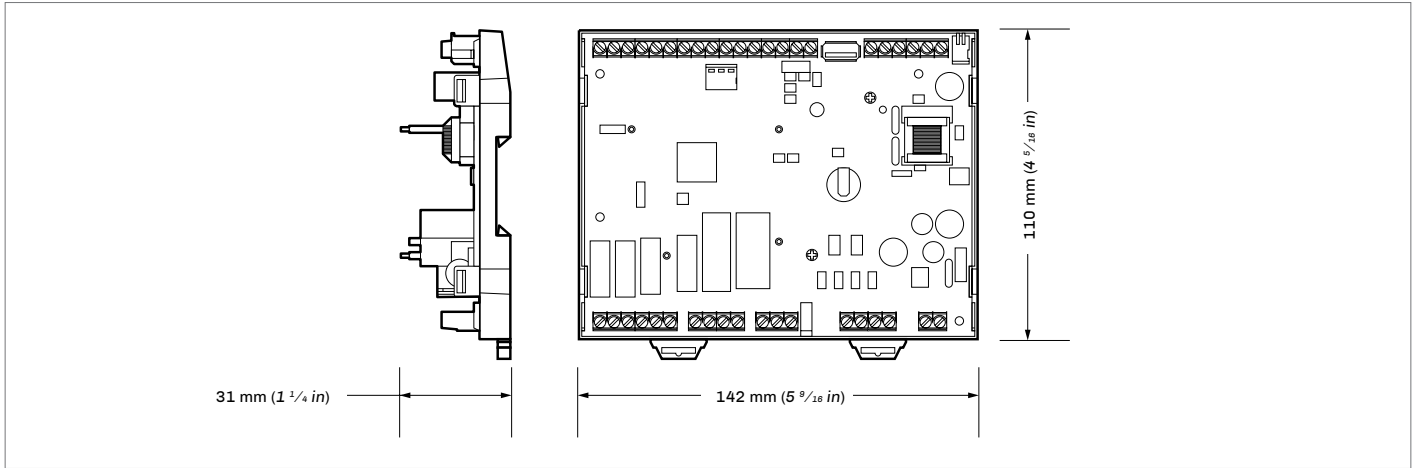

Plastic housing version (blind)

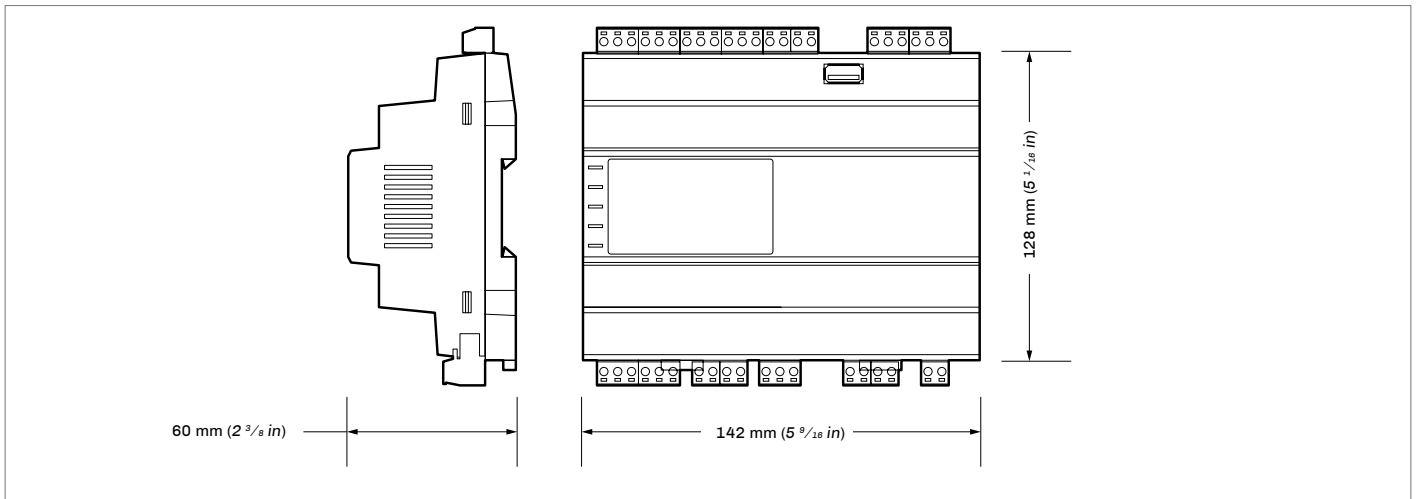

Plastic housing version (LCD)

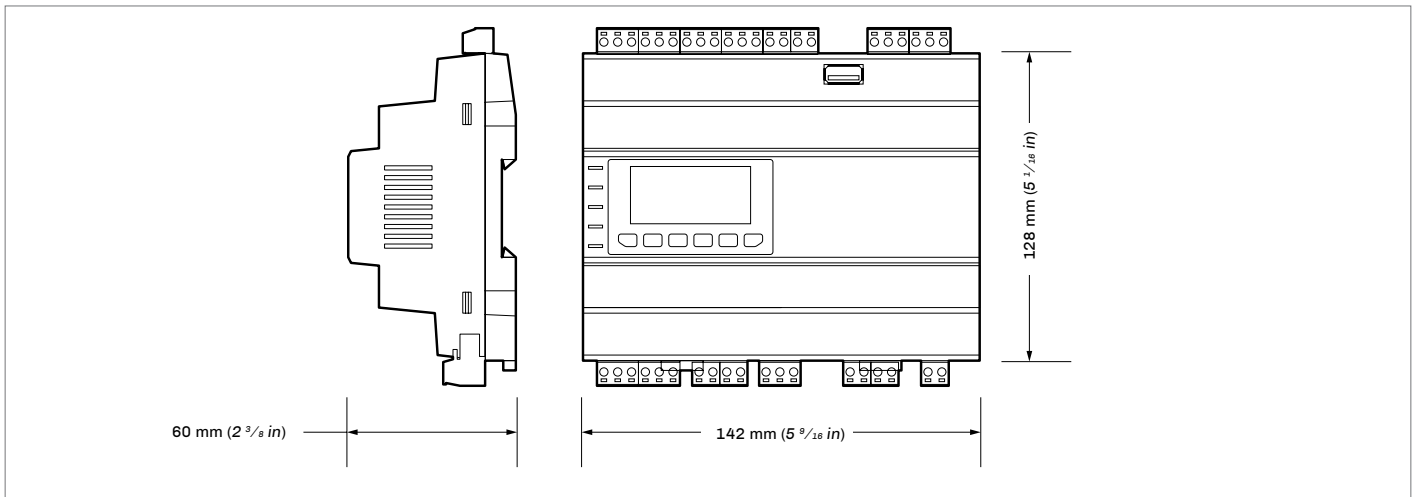

Installation

Open frame version

1. To install the device :
 - operate as shown in pictures 1 and 2

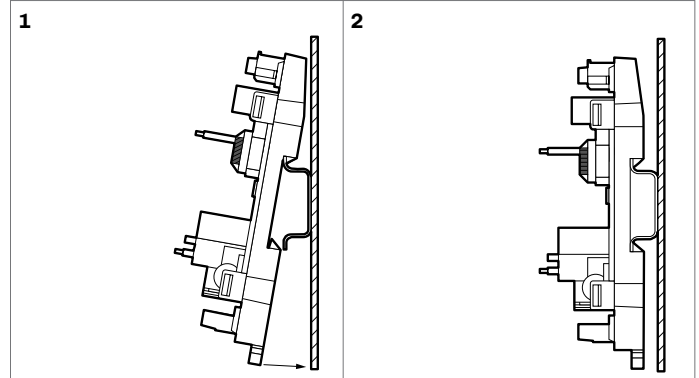

1. To uninstall the device:
 - operate as shown in pictures 3 and 4

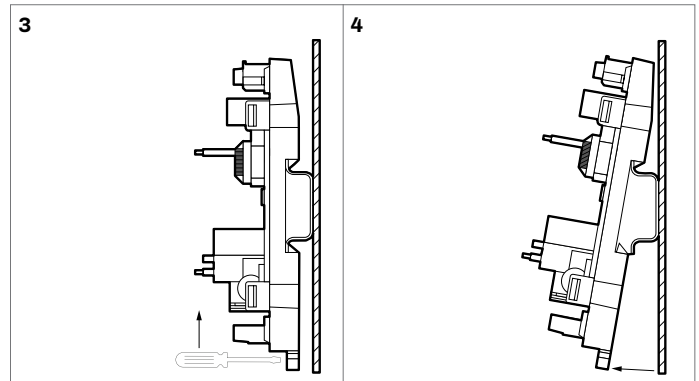

2. To install the device again:
 - press down the clip before

Plastic housing version (blind/LCD)

1. To install the device :
 - operate as shown in pictures 1 and 2

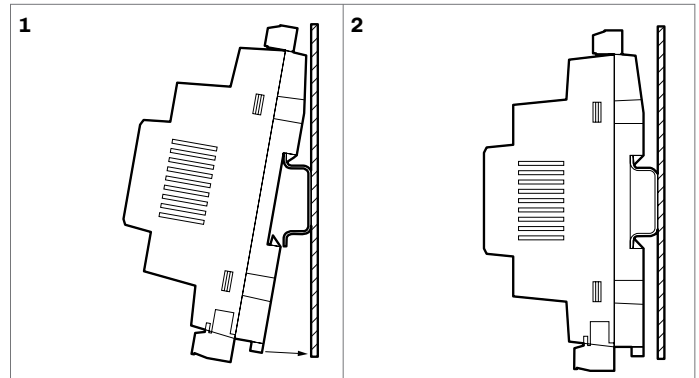

1. To uninstall the device:
 - first remove any screw-in removable terminal blocks mounted in the lower part, then operate as shown in pictures 3 and 4

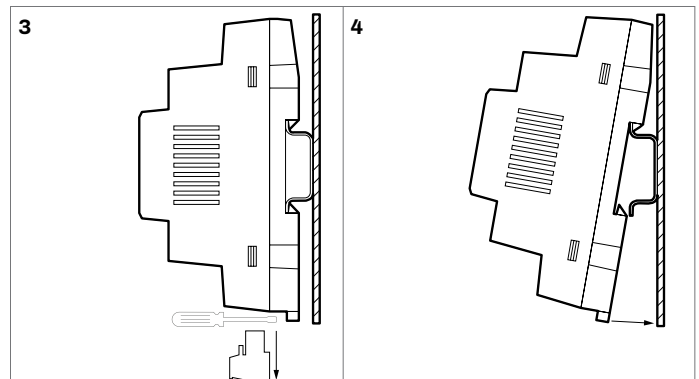

2. To install the device again:
 - press down the clip before

Electrical connections



WARNINGS FOR ELECTRICAL CONNECTIONS

- Use cables of an adequate section for the current running through them
- To reduce any electromagnetic interference connect the power cables as far away as possible from the signal cables and connect to a CAN, RS-485 MODBUS and INTRABUS networks by using a twisted pair
- If using an electrical or pneumatic screwdriver, adjust the tightening torque
- If the device has been moved from a cold to a warm place, the humidity may have caused condensation to form inside. Wait about an hour before switching on the power
- Make sure that the supply voltage, electrical frequency and power are within the set limits
- Disconnect the power supply before doing any type of maintenance
- Do not use the device as safety device
- For repairs and for further informations, contact the EVCO sales network; possible returns without label data will not be accepted

Connectors description

Open frame version

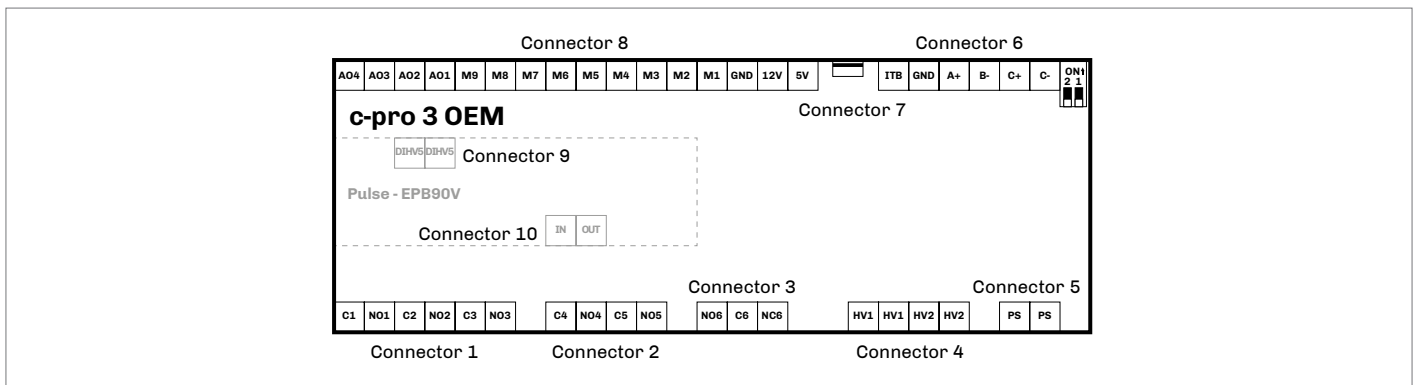

Connector 1

Number	Description
C1	K1 digital output common contact
NO1	K1 digital output normally open contact (5 A res. at 250 VAC)
C2	K2 digital output common contact
NO2	K2 digital output normally open contact (5 A res. at 250 VAC)
C3	K3 digital output common contact
NO3	K3 digital output normally open contact (5 A res. at 250 VAC)

Connector 3

Number	Description
NO6	K6 digital output normally open contact (16 A res. at 250 VAC)
C6	K6 digital output common contact
NC6	K6 digital output normally closed contact

Connector 2

Number	Description
C4	K4 digital output common contact
NO4	K4 digital output normally open contact (5 A res. at 250 VAC)
C5	K5 digital output common contact
NO5	K5 digital output normally open contact (8 A res. at 250 VAC)

Connector 4

Number	Description
HV1	DI1 High voltage digital input
HV1	DI1 High voltage digital input
HV2	DI2 High voltage digital input
HV2	DI2 High voltage digital input

Connector 5

Number	Description
PS	Device power supply (115... 230 VAC)
PS	Device power supply (115... 230 VAC)

Connector 7

Number	Description
USB	USB port, for device programming

Connector 9

Number	Description
DIHV5	High voltage digital input; DI5
DIHV5	High voltage digital input; DI5

Connector 6

Number	Description
ITB	INTRABUS port data
GND	Reference (GND)
A+	If present, signal + RS-485 MODBUS master/slave port
B-	If present, signal - RS-485 MODBUS master/slave port
C+	Signal + CAN port
C-	Signal - CAN port

Connector 8

Number	Description
AO4	Analogue output 4 (for 0-10 V or PWM)
AO3	Analogue output 3 (for 0-10 V or PWM)
AO2	Analogue output 2 (for 0-10 V or PWM)
AO1	Analogue output 1 (for 0-10 V or PWM)
M9	Digital input (dry contact and for pulse trains up to 2 KHz) DI4
M8	Digital input (dry contact and for pulse trains up to 2 KHz) DI3
M7	Analogue input (for PTC, NTC or Pt 1000 probes) AI7 can be configured also for dry contact digital input DI12
M6	Analogue input (for PTC, NTC or Pt 1000 probes) AI6 can be configured also for dry contact digital input DI11
M5	Analogue input (for PTC, NTC or Pt 1000 probes) AI5 can be configured also for dry contact digital input; DI10
M4	Analogue input (for PTC, NTC or Pt 1000 probes) AI4 can be configured also for dry contact digital input DI9
M3	Analogue input (for NTC probes, 0-5 V, 0-10 V, 0-20 mA or 4-20 mA transd.) AI3 can be configured also for dry contact digital input DI8
M2	Analogue input (for NTC probes, 0-5 V, 0-10 V, 0-20 mA or 4-20 mA transd.) AI2 can be configured also for dry contact digital input DI7
M1	Analogue input (for NTC probes, 0-5 V, 0-10 V, 0-20 mA or 4-20 mA transd.) AI1 can be configured also for dry contact digital input DI6
GND	Reference (GND)
12V	Auxiliary power supply (12 VDC)
5V	Ratiometric transducer power supply 0-5 V (5 VDC)

Connector 10

Number	Description
IN	Input Pulse digital output (230 VAC max. 30 W)
OUT	Pulse digital output

Plastic housing version (blind/LCD)

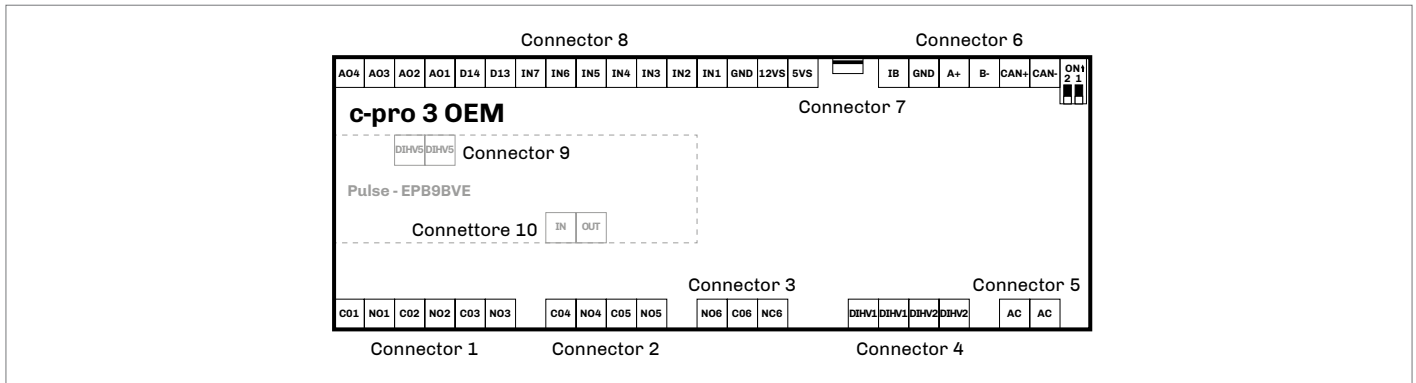

Connector 1

Number	Description
C01	K1 digital output common contact
N01	K1 digital output normally open contact (5 A res. at 250 VAC)
C02	K2 digital output common contact
N02	K2 digital output normally open contact (5 A res. at 250 VAC)
C03	K3 digital output common contact
N03	K3 digital output normally open contact (5 A res. at 250 VAC)

Connector 3

Number	Description
N06	K6 digital output normally open contact (16 A res. at 250 VAC)
C06	K6 digital output common contact
NC6	K6 digital output normally closed contact

Connector 5

Number	Description
AC	Device power supply (115... 230 VAC)
AC	Device power supply (115... 230 VAC)

Connector 2

Number	Description
C04	K4 digital output common contact
N04	K4 digital output normally open contact (5 A res. at 250 VAC)
C05	K5 digital output common contact
N05	K5 digital output normally open contact (8 A res. at 250 VAC)

Connector 4

Number	Description
DIHV1	DI1 High voltage digital input
DIHV1	DI1 High voltage digital input
DIHV2	DI2 High voltage digital input
DIHV2	DI2 High voltage digital input

Connector 6

Number	Description
IB	INTRABUS port data
GND	Reference (GND)
A+	If present, signal + RS-485 MODBUS master/slave port
B-	If present, signal - RS-485 MODBUS master/slave port
CAN+	Signal + CAN port
CAN-	Signal - CAN port

Connector 7

Number	Description
USB	USB port, for device programming

Connector 8

Number	Description
AO4	Analogue output 4 (for 0-10 V or PWM)
AO3	Analogue output 3 (for 0-10 V or PWM)
AO2	Analogue output 2 (for 0-10 V or PWM)
AO1	Analogue output 1 (for 0-10 V or PWM)
DI4	Digital input (dry contact and for pulse trains up to 2 KHz) DI4
DI3	Digital input (dry contact and for pulse trains up to 2 KHz) DI3
IN7	Analogue input (for PTC, NTC or Pt 1000 probes) AI7 can be configured also for dry contact digital input DI12
IN6	Analogue input (for PTC, NTC or Pt 1000 probes) AI6 can be configured also for dry contact digital input DI11
IN5	Analogue input (for PTC, NTC or Pt 1000 probes) AI5 can be configured also for dry contact digital input; DI10
IN4	Analogue input (for PTC, NTC or Pt 1000 probes) AI4 can be configured also for dry contact digital input DI9
IN3	Analogue input (for NTC probes, 0-5 V, 0-10 V, 0-20 mA or 4-20 mA transd.) AI3 can be configured also for dry contact digital input DI8
IN2	Analogue input (for NTC probes, 0-5 V, 0-10 V, 0-20 mA or 4-20 mA transd.) AI2 can be configured also for dry contact digital input DI7
IN1	Analogue input (for NTC probes, 0-5 V, 0-10 V, 0-20 mA or 4-20 mA transd.) AI1 can be configured also for dry contact digital input DI6
GND	Reference (GND)
12VS	Auxiliary power supply (12 VDC)
5VS	Ratiometric transducer power supply 0-5 V (5 VDC)

Connector 9

Number	Description
DIHV5	High voltage digital input; DI5
DIHV5	High voltage digital input; DI5

Connector 10

Number	Description
IN	Input Pulse digital output (230 VAC max. 30 W)
OUT	Pulse digital output

Electrical connection

Open frame version

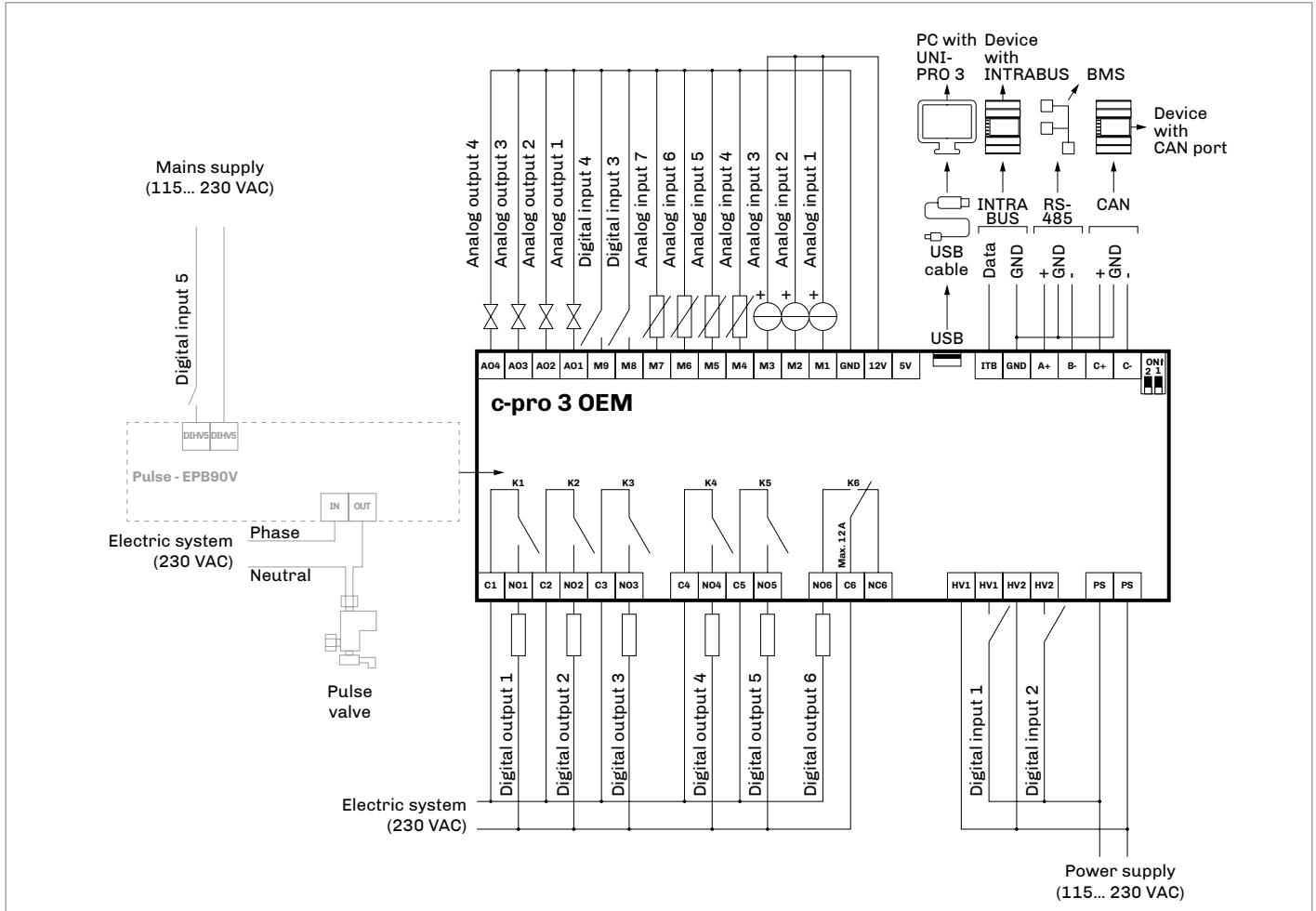

Termination of the RS-485 MODBUS and CAN networks. Polarisation of RS-485 MODBUS network

To terminate the RS-485 MODBUS network:
- Place the **micro-switch 1 in position ON**

To terminate the CAN network:
- Place the **micro-switch 2 in position ON**

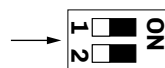

The RS-485 MODBUS network can be polarised using the UNI-PRO 3 development environment.

Plastic housing version (blind/LCD)

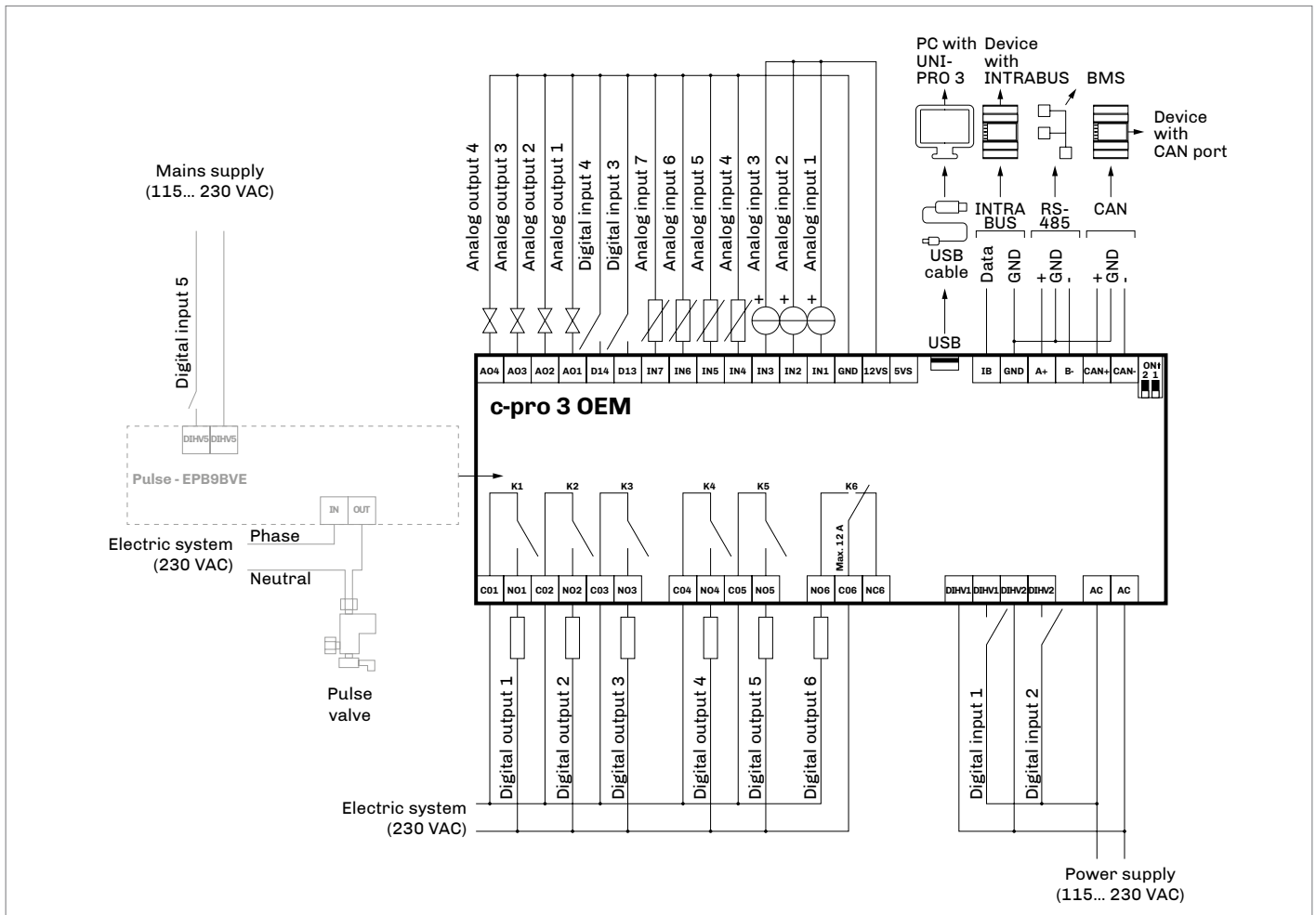

Termination of the RS-485 MODBUS and CAN networks.
Polarisation of RS-485 MODBUS network

To terminate the RS-485 MODBUS network:
- Place the **micro-switch 1 in position ON**

To terminate the CAN network:
- Place the **micro-switch 2 in position ON**

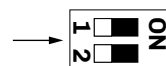

The RS-485 MODBUS network can be polarised using the UNI-PRO 3 development environment.

User interface version configuration

Keyboard

Key description

Keys	Instructions
esc	ESC
◀ ▶	LEFT AND RIGHT
▲ ▼	UP AND DOWN
↵	ENTER

Switching ON/OFF the device

Progression	Description
1	Connect the power supply: it will be started an internal test that takes typically a few seconds
2	Touch UP and DOWN keys for 2 seconds: the display will show the main menu
3	To switch OFF the device switch OFF the power supply

Accessing the procedure

Key	Instructions
▲ ▼	Touch UP and DOWN keys for 2 seconds: the display will show the main menu
esc	Touch ESC key few times to return to the previous displays

Accessing the menu

Key	Instructions
▲ ▼	Touch UP and DOWN keys for 2 seconds: the display will show the main menu
▲ ▼	Touch UP or DOWN keys to move the menu cursor
↵	Touch ENTER key to select the menu
esc	Touch ESC key few times to return to the previous displays

Parameters configuration

Key	Instructions
▲ ▼	Touch UP and DOWN keys for 2 seconds: the display will show the main menu
▲ ▼	Touch UP or DOWN keys to move the menu cursor
↵	Touch ENTER key to select the menu
▲ ▼	Touch UP or DOWN keys to see the parameters
↵	Touch ENTER key to select the parameter
▲ ▼	Touch UP or DOWN keys to set-up the value
↵	Touch ENTER key to confirm the value
esc	Touch ESC key few times to return to the previous displays

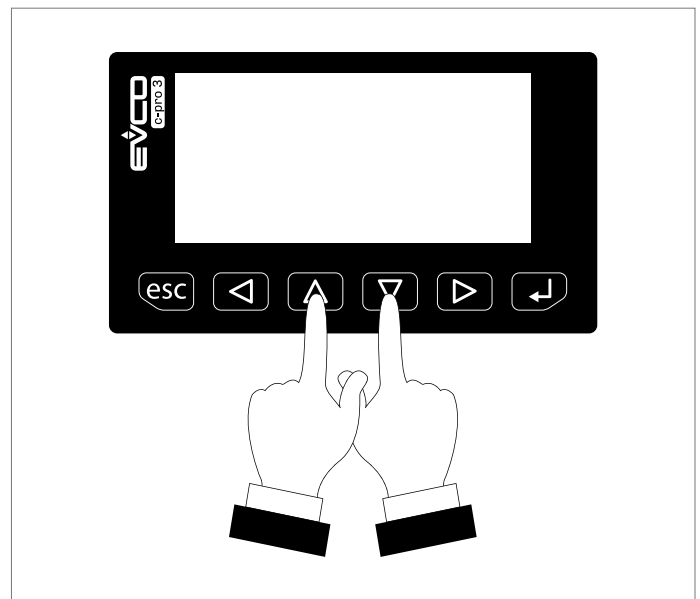
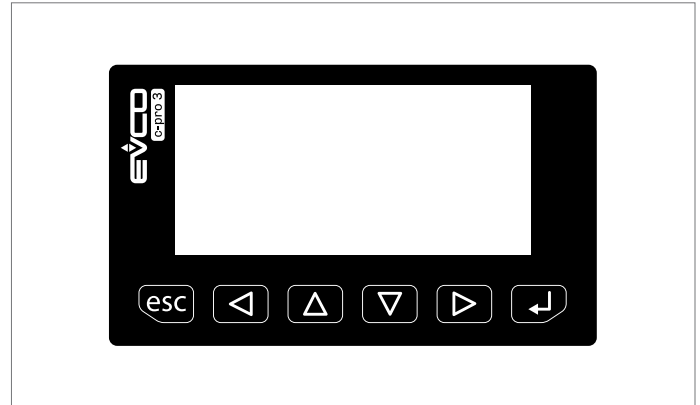

Password

Key	Instructions
▲ ▼	Touch UP and DOWN keys for 2 seconds: the display will show the main menu
▲ ▼	Touch UP or DOWN keys to see the menu "Password"
↵	Touch ENTER key to select the menu: the display will show "input password"
↵	Touch ENTER key to enter the password
▲ ▼	Touch UP or DOWN keys to set-up the password "-19"
↵	Touch ENTER key to confirm the password

Housing and blind version configuration

Through a controller with user interface

Configuration



The following procedures show an example of how to configure a blind programmable controller through a programmable controller with user interface (in the example c-pro 3 OEM LCD):

1. Disconnect the controllers power supply
2. Connect the blind controller to the controller with user interface through the CAN CANBUS port
3. Connect the controllers power supply





















Switching ON/OFF the device

Progression	Description
1	Connect the blind controller to the controller with user interface through the CAN CANBUS port
2	Touch UP and DOWN keys for 2 seconds: the display will show the main menu
3	To switch OFF the device switch OFF the power supply

Accessing the procedure from c-pro 3 OEM LCD

Key	Instructions
 	Touch UP and DOWN keys for 2 seconds: the display will show the main menu
esc	Touch ESC key few times to return to the previous displays

CAN node address setting



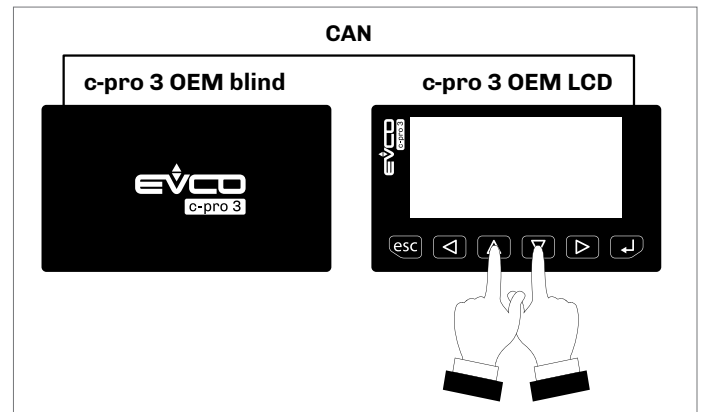

Key	Instructions
 	Touch UP and DOWN keys for 2 seconds: the display will show the main menu
 	Touch UP or DOWN keys to see the "Network" menu
	Touch ENTER key to select the menu
	Touch ENTER key to enter the password
 	Touch UP or DOWN keys to set-up the password "-19"
	Touch ENTER key to confirm the password
 	Touch UP or DOWN keys to see the "CAN Bus" menu
	Touch ENTER key to select the menu
 	Touch UP or DOWN keys to see the "NetworkNode" menu
	Touch ENTER key to select the menu
 	Touch UP or DOWN keys to set-up the node [1]
	Touch ENTER key to confirm the node
 	Touch UP and DOWN keys to select the right arrow ">"
	Touch ENTER key
esc	Touch ESC key few times to return to the previous displays

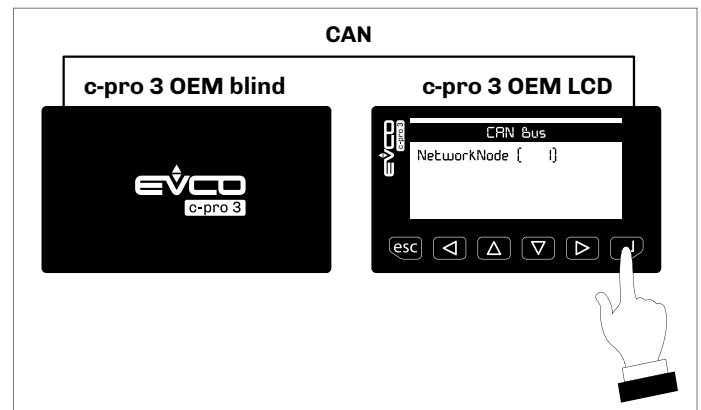











The default setting of the CAN node is 1. Operate on the controller with user interface to set the "NetworkNode" parameter to [1].











Accessing the menu from c-pro 3 OEM LCD

Key		Instructions
		Touch UP and DOWN keys for 2 seconds: the display will show the main menu
		Touch UP or DOWN keys to move the menu cursor
		Touch ENTER key to select the menu
esc		Touch ESC key few times to return to the previous displays

Parameters configuration from c-pro 3 OEM LCD

Key		Instructions
		Touch UP and DOWN keys for 2 seconds: the display will show the main menu
		Touch UP or DOWN keys to move the menu cursor
		Touch ENTER key to select the menu
		Touch UP or DOWN keys to see the parameters
		Touch ENTER key to select the parameter
		Touch UP or DOWN keys to set-up the value
		Touch ENTER key to confirm the value
esc		Touch ESC key few times to return to the previous displays

Password

Key		Instructions
		Touch UP and DOWN keys for 2 seconds: the display will show the main menu
		Touch UP or DOWN keys to see the menu "Password"
		Touch ENTER key to select the menu: the display will show "input password"
		Touch ENTER key to enter the password
		Touch UP or DOWN keys to set-up the password "-19"
		Touch ENTER key to confirm the password



Through a remote user interface

Configuration

The following procedures show an example of how to configure a programmable controller through a remote user interface (in the example EPJgraph):

1. Disconnect the power supply of the controller and the remote user interface
2. Connect the controller to the remote user interface through the CAN CANBUS port
3. Connect the power supply of the controller and the remote user interface

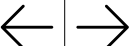
Key description



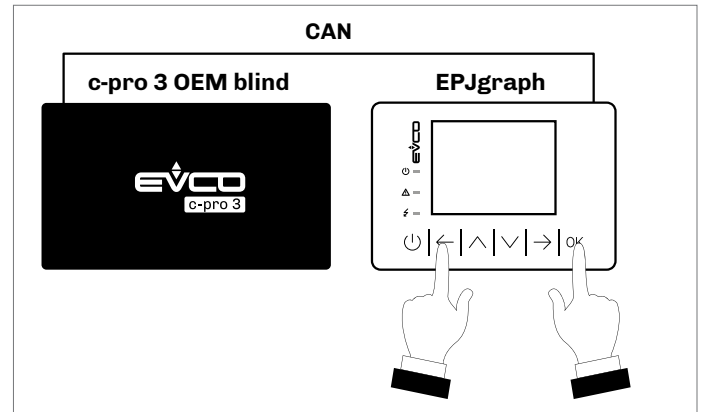

Key	Instructions
	ON/STAND-BY
	LEFT AND RIGHT
	UP AND DOWN
OK	ENTER









Switching ON/OFF the device from EPJgraph

Progression	Description
1	Connect the controller to the remote user interface through the CAN CANBUS port
2	Touch simultaneously the LEFT and ENTER keys to access the "Network Status (CAN)" screen
3	Touch the UP or DOWN keys to select the correct Node (Status "OK"), touch ENTER key
4	To switch OFF the device switch OFF the power supply

Accessing the procedure from EPJgraph

Key	Instructions
 OK	Touch simultaneously the LEFT and ENTER keys to access the "Network Status (CAN)" screen
 	Touch the UP or DOWN keys to select the correct Node (Status "OK")
OK	Touch ENTER key to access the main screen
	Touch ON/STAND-BY key a few times to return to the previous displays

Password

Key	Instructions
 OK	Touch simultaneously the LEFT and ENTER keys to access the "Network Status (CAN)" screen
 	Touch the UP or DOWN keys to select the correct Node (Status "OK")
OK	Touch ENTER key to access the main screen
 	Touch UP or DOWN keys to see the "password" menu
OK	Touch ENTER key to select the menu: the display will show "input password"
OK	Touch ENTER key to enter the password
 	Touch UP or DOWN keys to set-up the password "-19"
OK	Touch ENTER key to confirm the password

CAN node address setting

Key	Instructions
← OK	Touch simultaneously the LEFT and ENTER keys to access the "Network Status (CAN)" screen
^ √	Touch the UP or DOWN keys to select the correct Node (Status "OK")
OK	Touch ENTER key to access the main screen
^ √	Touch UP or DOWN keys to see the "Network" menu
OK	Touch ENTER key to select the menu
OK	Touch ENTER key to enter the password
^ √	Touch UP or DOWN keys to set-up the password "-19"
OK	Touch ENTER key to confirm the password
^ √	Touch UP or DOWN keys to see the "CAN Bus" menu
OK	Touch ENTER key to select the menu
^ √	Touch UP or DOWN keys to see the "NetworkNode" menu
OK	Touch ENTER key to select the menu
^ √	Touch UP or DOWN keys to set-up the node [1]
OK	Touch ENTER key to confirm the node
^ √	Touch UP and DOWN keys to select the right arrow ">"
OK	Touch ENTER key
⏻	Touch ESC key few times to return to the previous displays

The default setting of the CAN node is 1.
Operate on the remote user interface to set the "NetworkNode" parameter to [1].

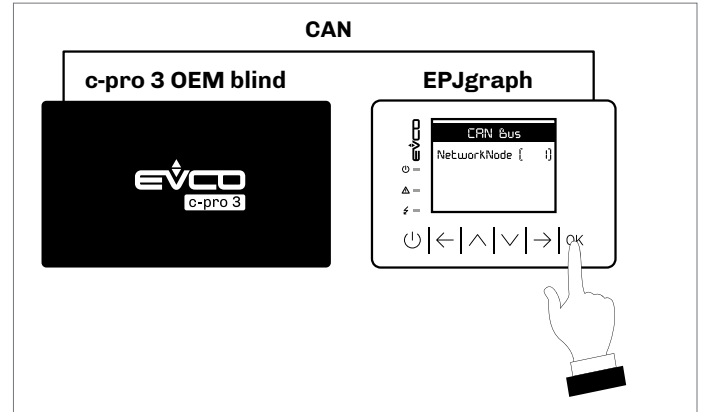

Accessing the menu from EPJgraph

Key	Instructions
← OK	Touch simultaneously the LEFT and ENTER keys to access the "Network Status (CAN)" screen
^ √	Touch the UP or DOWN keys to select the correct Node (Status "OK")
OK	Touch ENTER key to access the main screen
^ √	Touch UP or DOWN keys to move the menu cursor
OK	Touch ENTER key to select the menu
⏻	Touch ON/STAND-BY key a few times to return to the previous displays

Parameters configuration from EPJgraph

Key	Instructions
← OK	Touch simultaneously the LEFT and ENTER keys to access the "Network Status (CAN)" screen
^ √	Touch the UP or DOWN keys to select the correct Node (Status "OK")
OK	Touch ENTER key to access the main screen
^ √	Touch UP or DOWN keys to select the "Parameters" menu
OK	Touch ENTER key
^ √	Touch UP or DOWN keys to select a parameter
OK	Touch ENTER key
^ √	Touch UP or DOWN keys to set-up the value
OK	Touch ENTER key
⏻	Touch ON/STAND-BY key a few times to return to the previous displays

LED

LED description

Key	instructions
ON	Power supply LED <ul style="list-style-type: none"> - If ON the device is powered - If OFF the device is not powered
RUN	Run LED <ul style="list-style-type: none"> - If ON the application software shall be compiled and executed in release mode - If flashing very slowly the application software shall be compiled in debug mode - If flashing slowly the application software shall be executed in debug mode - If flashing quickly the application software shall be compiled, executed in debug mode and stopped at a breakpoint - If OFF: <ul style="list-style-type: none"> - the device is not compatible with the application software - the device is not authorised to operate with the Special ABL (Application Block Libraries)
⚠	System alarm LED <ul style="list-style-type: none"> - If ON a system alarm has been triggered that cannot be reset through the application software - If flashing very slowly the external FLASH memory is being accessed - If flashing slowly a system alarm had been triggered with automatic reset - If flashing quickly a system alarm had been triggered with manual reset - If OFF no system alarm has been triggered
CAN	CAN CANBUS communication LED <ul style="list-style-type: none"> - If ON the device is configured to communicate via CAN CANBUS with another device, but the communication has not been established - If flashing slowly the CAN CANBUS communication has been established, but is not entirely correct - If flashing quickly the CAN CANBUS communication shall established and be entirely correct - If OFF no CAN CANBUS communication is in progress
L1	Auxiliary LED The operation of this LED can be set via the UNI-PRO 3 development environment

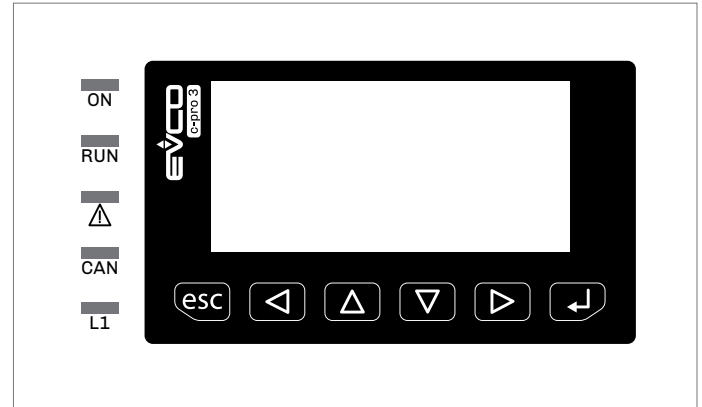

Settings menu







Keys description and parameters settings



WARNINGS

Turn off the power after changing the configuration

Menu "Info" keys

Keys		Instructions
		Touch UP and DOWN keys for 2 seconds: the display will show the main menu
		Touch UP or DOWN keys to see the menu "Info"
		Touch ENTER key to select the menu
		Touch UP or DOWN keys to see the parameters
esc		Touch ESC key few times to return to the previous displays

Menu "Info" parameters

N.	Param.	Def.	"Info" menu	Min/max
1	PROJ	-	Application project: - projet - version - revision	-
2	FW	-	Firmware: - code - version - revision	-
3	HW	-	Hardware: - version - revision - generic (G) special (S)	-
4	SW	-	UNI-PRO 3 development environment: - version - revision	-
5	SN	-	Serial number and results of the production tests	-
6	MASK	-	Mask	-
7	DATE	-	Date and time of the latest compilation	-













Menu "Languages" keys

Keys		Instructions
△	▽	Touch UP and DOWN keys for 2 seconds: the display will show the main menu
△	▽	Touch UP or DOWN keys to see the menu "English"
↵		Touch ENTER key to select the menu
△	▽	Touch UP or DOWN keys to see the languages
↵		Touch ENTER key to select the language
esc		Touch ESC key few times to return to the previous displays

Menu "Languages" parameters

N.	Param.	Def.	"Languages" menu	Min/max
8	English	-	English	-
9	Italiano	-	Italian	-
10	Francoise	-	French	-
11	Espanol	-	Spanish	-
12	Deutsch	-	German	-
13	Russian	-	Russian	-
14	Portoguese	-	Portuguese	-

Menu "Parameters" keys

Keys	Instructions
 	Touch UP and DOWN keys for 2 seconds: the display will show the main menu
 	Touch UP or DOWN keys to see the menu "parameters"
	Touch ENTER key to select the menu
 	Touch UP or DOWN keys to see the parameters (list 1)
	Touch RIGHT key to see the parameters (list 1)
	Touch LEFT key to return to parameters (list 1)
	Touch ENTER key to select the parameter
 	Touch UP or DOWN keys to set-up the value
	Touch ENTER key to confirm the value
esc	Touch ESC key few times to return to the previous displays

Menu "Parameters (1)" parameters

N.	Param.	Def.	"Parameters" menu	Min/max
15	AI1	NTC	Type of probe analog port 1	PTC = PTC probe NTC = NTC probe 0-20mA = Transducer 0-20 mA 4-20mA = Transducer 4-20 mA 0-5V = Transducer 0-5 V ratiometric 0-10V = Transducer 0-10 V PT1000 = Pt 1000 probe NTCK2 = Type 2 NTC probe NTCK3 = Type 3 NTC probe RESIST = electric resistance reading
16	AI2	NTC	Type of probe analog port 2	PTC = PTC probe NTC = NTC probe 0-20mA = Transducer 0-20 mA 4-20mA = Transducer 4-20 mA 0-5V = Transducer 0-5 V ratiometric 0-10V = Transducer 0-10 V PT1000 = Pt 1000 probe NTCK2 = Type 2 NTC probe NTCK3 = Type 3 NTC probe RESIST = electric resistance reading
17	AI3	NTC	Type of probe analog port 3	PTC = PTC probe NTC = NTC probe 0-20mA = Transducer 0-20 mA 4-20mA = Transducer 4-20 mA 0-5V = Transducer 0-5 V ratiometric 0-10V = Transducer 0-10 V PT1000 = Pt 1000 probe NTCK2 = Type 2 NTC probe NTCK3 = Type 3 NTC probe RESIST = electric resistance reading
18	AI4	NTC	Type of probe analog port 4	PTC = PTC probe NTC = NTC probe PT1000 = Pt 1000 probe NTCK2 = Type 2 NTC probe NTCK3 = Type 3 NTC probe RESIST = electric resistance reading

Menu "Parameters (1)" parameters

N.	Param.	Def.	"Parameters" menu	Min/max
19	AI5	NTC	Type of probe analog port 5	PTC = PTC probe NTC = NTC probe PT1000 = Pt 1000 probe NTCK2 = Type 2 NTC probe NTCK3 = Type 3 NTC probe RESIST = electric resistance reading
20	AI6	NTC	Type of probe analog port 6	NTC = NTC probe PT1000 = Pt 1000 probe NTCK2 = Type 2 NTC probe NTCK3 = Type 3 NTC probe RESIST = electric resistance reading
21	AI7	NTC	Type of probe analog port 7	PTC = PTC probe NTC = NTC probe 0-20mA = Transducer 0-20 mA 4-20mA = Transducer 4-20 mA 0-5V = Transducer 0-5 V ratiometric 0-10V = Transducer 0-10 V PT1000 = Pt 1000 probe NTCK2 = Type 2 NTC probe NTCK3 = Type 3 NTC probe RESIST = electric resistance reading
22	AI Err Time	2	Analog ports time-out	If no communication with an analog port is detected after this span of time, the controller notifies an analog input error
23	A01	0-10V	Type of signal analog port 1	0-10V = 0-10 V PWM = PWM (Pulse With Modulation)
24	freq	1000	Frequency of the analog port 1 PWM-type signal	-
25	A02	0-10V	Type of signal analog port 2	0-10V = 0-10 V PWM = PWM (Pulse With Modulation)
26	freq	1000	Frequency of the analog port 2 PWM-type signal	-
27	A03	0-10V	Type of signal analog port 3	0-10V = 0-10 V PWM = PWM (Pulse With Modulation)
28	freq	1000	Frequency of the analog port 3 PWM-type signal	-
29	A04	0-10V	Type of signal analog port 4	0-10V = 0-10 V PWM = PWM (Pulse With Modulation)
30	freq	1000	Frequency of the analog port 4 PWM-type signal	-















Menu "Parameters (2)" parameters

N.	Param.	Def.	"Parameters" menu	Min/max
31	I/O Timeout	60	CANBUS communication time-out to check the remote I/O values	After this span of time has elapsed with no CANBUS communication, the controller I/O is disabled
32	En. Prg Level	NO	Access to the level first page enabled by pressing a combination of keys	YES = yes NO = no
33	Password indi	NO	Restriction between the access passwords of the various levels	NO = It is not necessary to set a password to access the levels below the one already accessed YES = it is necessary to set a password to access each level
34	Backlight	TIME	Type of backlight	OFF = the backlight is never ON ON = the backlight is always ON TIME = the backlight stays on for the period of time after the latest key operation set with the B. Time parameter
35	B. Time	240	Backlight duration	Only if the Backlight parameter is set in TIME mode
36	Contrast	20	Display contrast	-
37	Date Char Sep	/	Date separator ASCII character	-

Menu "Parameters (2)" parameters

N.	Param.	Def.	"Parameters" menu	Min/max
38	Year format	YY	Year format	YY = two digits (e.g. 19) YYYY = four digits (e.g. 2019)
39	Date format	D-M-Y	Date format	D-M-Y = day, month and year M-D-Y = month, day and year Y-M-D = year, month and day
40	Time Char Separator	:	Time separator ASCII character	-
41	Time With Sec	YES	Time displayed with seconds	YES = yes NO = no
42	Time AM/PM	NO	Time format	NO = 24 h (e.g. 15:20) YES = 12 h (e.g. 3:20 PM)

Menu "Networks" keys

Keys	Instructions
 	Touch UP and DOWN keys for 2 seconds: the display will show the main menu
 	Touch UP or DOWN keys to see the menu "Networks"
	Touch ENTER key to select the menu
 	Touch UP or DOWN keys to see the submenu
	Touch ENTER key to select the submenu
 	Touch UP or DOWN keys to set-up the value
	Touch ENTER key to confirm the value
 	Touch LEFT or RIGHT keys to see the other screen
	Touch ESC key few times to return to the previous displays

Menu "Networks" - Submenu "CAN Bus" parameters

N.	Param.	Def.	"CAN Bus" submenu	Min/max
43	MyNode	1	Local CAN node or device address	
44	Master	YES	Enabled to function as master in a CAN network	YES = yes NO = no
45	Baud	20K	Baud rate of the CAN-type communication	20K = 20.000 baud 50K = 50.000 baud 125K = 125.000 baud 500K = 500.000 baud
46	Timeout	5	Remote CAN-type communication timeout, i.e., communication with the other network elements	After the time set with this parameter has elapsed with no CAN-type communication with an element, the element is disabled
47	Network Node	[1] 99	Address of the CAN nodes or of the other network elements (e.g. [1] 2)	[1] = node 2 = node address
48	TSEG1	-	-	Reserved
49	TSEG2	-	-	Reserved
50	SJW	-	-	Reserved
51	BTR	-	-	Reserved

Menu "Networks" - Submenu "CAN Bus" parameters

N.	Param.	Def.	"CAN Bus" submenu	Min/max
52	Status	OPERAT	CAN machine status	INIT = initialisation STOPPED = stop CAN OPERAT = operating PRE-OP = in pre-operating mode
53	Bus Status	PASSIVE	CAN bus status	OK = status OK WARNING = attention PASSIVE = bus in receiving mode only BUS OFF = bus stopped
54	Cnt Rx	-	Number of packets received	-
55	Cnt Tx	-	Number of packets sent	-
56	Cnt Ovf	-	Number of overflow packets	-
57	Cnt Passive	-	Number of passages to the passive state	-
58	Cnt Bus Off	-	Number of passages to the passive state	-
59	Cnt Rx Err	-		-
60	Cnt Tx Err	-		-
61	Cnt Stuff	-		-
62	Cnt Form	-		-
63	Cnt Ack	-		-
64	Cnt Bit1	-		-
65	Cnt Bit 0	-		-
66	Cnt CRC	-		-
67	PDO TX1	-		-
68	Force	-		-

Menu "Networks" - Submenu "UART1" parameters

N.	Param.	Def.	"UART1" submenu	Min/max
43	Address	1	Indirizzo MODBUS del dispositivo	Significant only if the communication protocol is of the MODBUS slave type
44	Baudrate	9600	Baud rate of the MODBUS-type communication	1200 = 1.200 baud 2400 = 2.400 baud 4800 = 4.800 baud 9600 = 9.600 baud 19200 = 19.200 baud 28800 = 28.800 baud 38400 = 38.400 baud 57600 = 57.600 baud
45	Parity	EVEN	MODBUS-type communication parity	NONE = none ODD = odd EVEN = even
46	Stop	1 BIT	Number of stop bits of the MODBUS-type communication	1 BIT = 1 bit 2 BIT = 2 bit

Menu "Networks" - Submenu "UART2" parameters

N.	Param.	Def.	"UART2" submenu	Min/max
47	Address	1	MODBUS address of the device	Significant only if the communication protocol is of the MODBUS slave type
48	Baudrate	9600	Baud rate of the MODBUS-type communication	1200 = 1.200 baud 2400 = 2.400 baud 4800 = 4.800 baud 9600 = 9.600 baud 19200 = 19.200 baud 28800 = 28.800 baud 38400 = 38.400 baud 57600 = 57.600 baud
49	Parity	EVEN	MODBUS-type communication parity	NONE = none ODD = odd EVEN = even
50	Stop	1 BIT	Number of stop bits of the MODBUS-type communication	1 BIT = 1 bit 2 BIT = 2 bit Timeout 0

Menu "Networks" - Submenu "USB" parameters

N.	Param.	Def.	"USB" submenu	Min/max
51	USB Status Device	-	-	Reserved
52	Device Status Idle Speed	-	-	Reserved

Menu "Password" keys

Keys		Instructions
△	▽	Touch UP and DOWN keys for 2 seconds: the display will show the main menu
△	▽	Touch UP or DOWN keys to see the menu "Password"
↵		Touch ENTER key to select the menu
△	▽	Touch UP or DOWN keys to see the parameters
↵		Touch ENTER key to select the parameter
△	▽	Touch UP or DOWN keys to set-up the value
↵		Touch ENTER key to confirm the value
esc		Touch ESC key few times to return to the previous displays

Menu "Password" parameters

N.	Param.	Def.	"Password" menu	Min/max
53	Level 1:	0	Value of the level 1 access password	
		ON	Enabling of the level 1 access password	OFF = no password needs to be set to access level 1 ON = it is necessary to set a password to access level 1
54	Level 2:	0	Value of the level 2 access password	
		ON	Enabling of the level 2 access password	OFF = no password needs to be set to access level 2 ON = it is necessary to set a password to access level 2
55	Level 3:	0	Value of the level 3 access password	
		ON	Enabling of the level 3 access password	OFF = no password needs to be set to access level 3 ON = it is necessary to set a password to access level 3
55	Level 4:	0	Value of the level 4 access password	
		ON	Enabling of the level 4 access password	OFF = no password needs to be set to access level 4 ON = it is necessary to set a password to access level 4
56	Level 5:	0	Value of the level 5 access password	
		ON	Enabling of the level 5 access password	OFF = no password needs to be set to access level 5 ON = it is necessary to set a password to access level 5
57	Timeout	240	Timeout of access passwords	After this time has elapsed from the latest keypad operation, it is necessary to set a new password to access the relevant level, if so required

Menu "Backup/Restore" keys

Keys		Instructions
△	▽	Touch UP and DOWN keys for 2 seconds: the display will show the main menu
△	▽	Touch UP or DOWN keys to see the menu "Backup/Restore"
↵		Touch ENTER key to select the menu
△	▽	Touch UP or DOWN keys to see the parameters
↵		Touch ENTER key to select the parameter
esc		Touch ESC key few times to return to the previous displays

Menu "Backup/Restore" parameters

N.	Param.	Def.	"Backup/Restore" menu	Min/max
58	-		Parameters Key	Save on key Restore from key
59	-		Backup Memory	Save on memory Restore from memory

Accessories

Connection cables

0810500018/0810500020

Makes it possible to connect via a USB to a personal computer or other device with a USB port.

Cable length

Code	Length
0810500018	2 m
0810500020	0.5 m



USB flash drive

EVUSB4096M

Makes possible configuration upload and download. 4GB of memory.



RS-485/USB serial interface

EVIF20SUXI

Using the RS-485 communications port, the controller can be connected to the Parameters Manager set-up software. Non-optoisolated.



INTRABUS/RS-485 serial interface

EVIF22ISX

Makes it possible to convert the INTRABUS signal into an RS-485.



Phase cutting speed regulator

EVDFAN1

Makes it possible to regulate a single-phase fan speed with a PWM command signal.

The maximum operating current is 5 A.



Connection kit

CJAV45

Enables cabling of the c-pro 3 OEM plastic housing version (blind/LCD).



Technical data

Type	Description	
Purpose of the control device	Function controller	
Construction of the control device	Built-in electronic device	
Container	Grey, self-extinguishing	
Category of heat and fire resistance	D	
Dimensions	Open frame version	- 142 x 110 x 31 mm (5 ^{9/16} x 4 ^{5/16} x 1 ^{1/4} in)
	Plastic housing version	- 142 x 128 x 60 mm (5 ^{9/16} x 5 ^{1/16} x 2 ^{3/8} in)
Mounting methods for the control device	To be fitted on a DIN rail, in a control panel	
Degree of protection provided by the covering	Open frame version	IP00
	Plastic housing version	IP20
Connection method	Open frame version	- Screw terminal blocks for wires up to 2.5 mm ² - Type A female USB connector.
	Plastic housing version	- Removable screw terminal blocks for wires up to 2.5 mm ² - Type A female USB connector.
Maximum permitted length for connection cables	Power supply: 10 m (32.8 ft)	
	Analogue inputs: 10 m (32.8 ft)	
	Auxiliary power supply and 0-5 V ratiometric transducer power supply: 10 m (32.8 ft)	
	Digital inputs: 10 m (32.8 ft)	
	0-10 V analogue outputs: 10 m (32.8 ft)	
	PWM analogue outputs: 1 m (3.28 ft)	
	Digital outputs: 100 m (328 ft)	
	INTRABUS port: 10 m (32.8 ft)	
	RS-485 MODBUS port: 1.000 m (3.280 ft)	
	USB port: 1 m (3.28 ft)	
Operating temperature	Open frame version	-20 – 60 °C (-4 – 140 °F)
	Plastic housing version - blind	-20 – 55 °C (-4 – 131 °F)
	Plastic housing version - LCD	-10 – 55 °C (14 – 131 °F)
Storage temperature	Open frame version	-20 – 70 °C (-4 – 158 °F)
	Plastic housing version - LCD	-20 – 70 °C (-4 – 158 °F)
	Plastic housing version - blind	-20 – 70 °C (-4 – 158 °F)
Operating humidity	Relative humidity without condensate from 5 to 95%	
Pollution status of the control device	2	
Compliance	- RoHS 2011/65/CE	
	- WEEE 2012/19/EU	
	- REACH (EC) Regulation no. 1907/2006	
	- EMC 2014/30/UE	
Power supply	- LVD 2014/35/UE	
	115.. 230 VAC (+10% -15%) 50/60 Hz (±3 Hz) max. 10 VA	
Earthing methods for the control device	None	

Type	Description	
Rated impulse-with stand voltage	4 KV	
Over-voltage category	III	
Software class and structure	A	
Real Time Clock	According to the model (with secondary lithium battery)	
Clock drift	≤ 60s/month at 25 °C (77 °F)	
Clock battery autonomy in the absence of a power supply	> 6 months at 25 °C (77 °F)	
Clock battery charging time	24h (the battery is charged by the power supply of the device)	
Analogue inputs	4 for PTC, NTC or Pt 1000 probes (can be configured also for dry contact digital input)	
	3 for NTC probes, 0-5 V, 0-10 V, 0-20 mA or 4-20 mA transducers (can be configured also for dry contact digital input)	
PTC probes	Sensor type	KTY 81 – 121 (990 Ω a 25 °C (77 °F))
	Measurement field:	-50 – 150 °C (-58 – 302 °F)
	Resolution	0.1 °C (1 °F)
NTC probes	Sensor type	β3435 (10 KΩ a 25 °C (77 °F))
	Measurement field	-50 – 120 °C (-58 – 248 °F)
	Resolution	0.1 °C (1 °F)
Pt 1000 probes	Sensor type	1 KΩ – 0 °C (32 °F)
	Measurement field	-100 – 400 °C (-148 – 752 °F)
	Resolution	0.1 °C (1 °F)
0-5 V transducers	Input resistance	≥ 10 KΩ
	Resolution	0.01 V
0-10 V transducers	Input resistance	≥ 10 KΩ
	Resolution	0.01 V
4-20 mA transducers	Input resistance	≤ 200 Ω
	Resolution	0.01 mA
Auxiliary power supply:	Open frame version	12 VDC +10 % -15 % 160 mA max
	Plastic housing version	12 VDC +10 % -15 % 100 mA max
Ratiometric transducer power supply	Open frame version	5 VDC +10 % -15 % 10 mA max
	Plastic housing version	5 VDC +10 % -15 % 10 mA max
Digital inputs:	2 dry contact and for pulse trains up to 2 KHz 2 high voltage (3 for EPB90V - EPB9BVE models)	
Dry contact	Contact type	3,3 VDC, 1 mA
	Power supply	None
High voltage contac	Power supply	115... 230 VAC
Analogue outputs	4 for 0-10 V or PWM signal	
0-10 V signal	Minimum applicable impedance	1 KΩ
	Resolution	0.01 V
PWM signal	Power supply	0... 10 VDC (+16 % -25 %) 10 mA max
	Frequency	10 Hz... 2 KHz
	Duty	0... 100 %

Type	Description	
Digital outputs	4 with SPST electro-mechanical relay, 5 A res. at 250 VAC	
	1 with SPST electro-mechanical relay, 8 A res. at 250 VAC	
	1 with SPDT electro-mechanical relay, 16 A res. at 250 VAC	
	1 Pulse, 230 VAC max. 30 W (only for EPB90V - EPB9BVE models)	
The device guarantees reinforced insulation between each digital output connector and the rest of the components of the device		
Type 1 or Type 2 Actions	Type 1	
Additional features of Type 1 or Type 2 actions	C	
Displays	Open frame version	None
	Plastic housing version - blind	None
	Plastic housing version - LCD	128 x 64 pixel single colour LCD graphic display
Communications ports	- 1 CAN port	
	- 1 USB port	
	- 1 INTRABUS port	
	- 1 RS-485 MODBUS MASTER SLAVE port (according to the model)	

1 MB program memory (only models EPB90I and EPB90IE).



EVCO S.p.A.

Via Feltre 81, 32036 Sedico (BL) ITALY

| Tel. +39 0437 8422

| Fax +39 0437 83648

| e-mail info@evco.it

| web www.evco.it

This document and the solutions contained therein are the intellectual property of EVCO and thus protected by the Italian Intellectual Property Rights Code (CPI). EVCO imposes an absolute ban on the full or partial reproduction and disclosure of the content other than with the express approval of EVCO. The customer (manufacturer, installer or end-user) assumes all responsibility for the configuration of the device. EVCO accepts no liability for any possible errors in this document and reserves the right to make any changes, at any time without prejudice to the essential functional and safety features of the equipment.