

# Slim Power series inverter

Inverter for medium power asynchronous motors

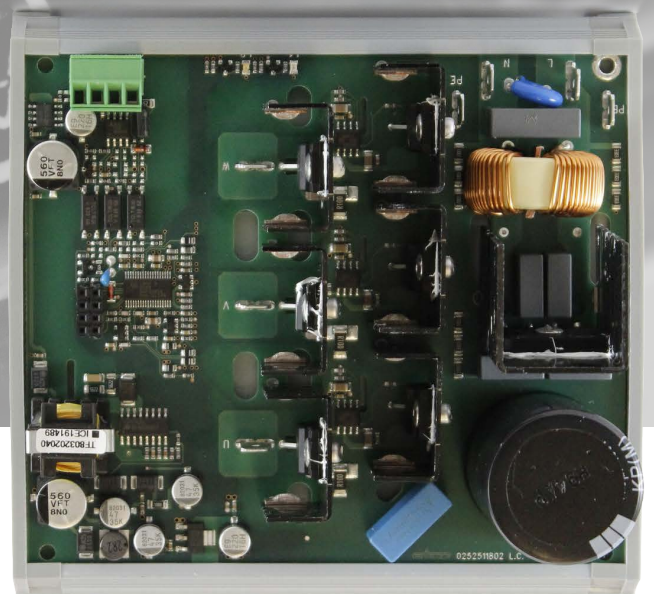

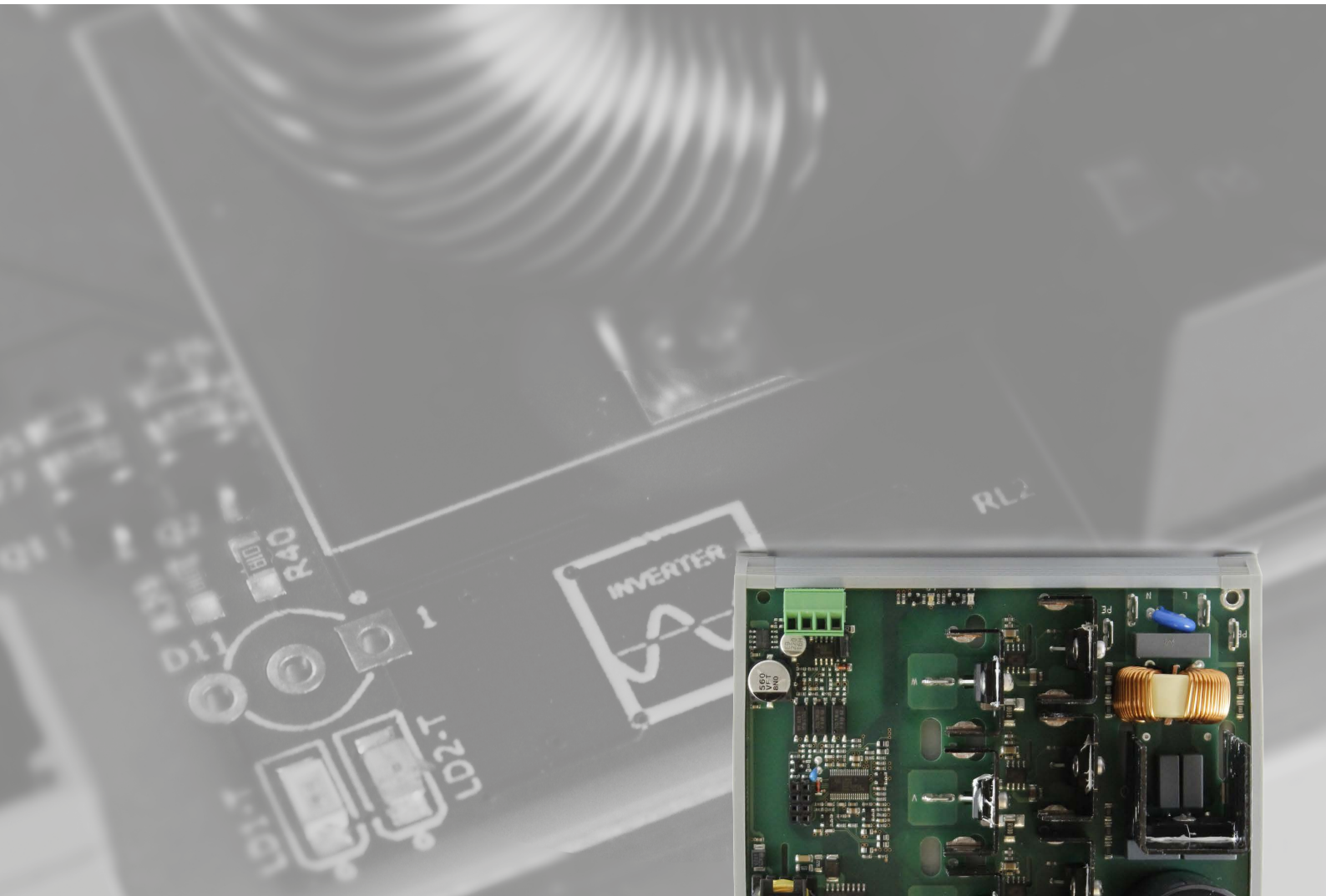

## CONTENTS

<b>IMPORTANT INFORMATION</b>	<b>4</b>
<b>IMPORTANT SAFETY INFORMATION</b>	<b>5</b>
<b>SAFETY INFORMATION RELATING TO THE PRODUCT</b>	<b>6</b>
<b>CHAPTER 1. INTRODUCTION</b>	<b>8</b>
<b>1.1 Compliance</b>	<b>8</b>
<b>CHAPTER 2. PURCHASING CODES</b>	<b>9</b>
<b>2.1 Purchasing codes table</b>	<b>9</b>
<b>CHAPTER 3. TECHNICAL DATA</b>	<b>10</b>
<b>3.1 Technical specifications</b>	<b>10</b>
<b>3.2 Other technical information</b>	<b>10</b>
<b>CHAPTER 4. MECHANICAL ASSEMBLY</b>	<b>11</b>
<b>4.1 Installation</b>	<b>11</b>
<b>4.2 Minimum installation distances</b>	<b>12</b>
<b>4.3 Dimensions</b>	<b>13</b>
<b>4.4 Installation method</b>	<b>13</b>
<b>CHAPTER 5. ELECTRICAL CONNECTIONS</b>	<b>14</b>
<b>5.1 Connection best practice</b>	<b>14</b>
<b>5.1.1 Wiring best practices</b>	<b>15</b>
<b>5.2 Wiring diagrams</b>	<b>16</b>
<b>5.2.1 Slim Power FM</b>	<b>16</b>
<b>5.2.2 Slim Power RS-485</b>	<b>16</b>
<b>5.2.3 Slim Power AI</b>	<b>16</b>
<b>5.2.4 Earthing</b>	<b>17</b>
<b>CHAPTER 6. OPERATION</b>	<b>18</b>
<b>6.1 Control types</b>	<b>18</b>
<b>6.2 Protection</b>	<b>18</b>
<b>6.3 LED</b>	<b>18</b>
<b>6.4 AUTO-RESET function</b>	<b>18</b>
<b>6.5 SAFE START function</b>	<b>18</b>
<b>CHAPTER 7. PARAMETERS</b>	<b>19</b>
<b>7.1 Table of Slim Power RS-485 configuration parameters</b>	<b>19</b>
<b>7.2 Table of Modbus commands</b>	<b>21</b>
<b>7.3 Serial communication settings</b>	<b>21</b>
<b>7.4 Table of Modbus variables</b>	<b>22</b>



## CONTENTS

---

	<b>7.5 Table of monitor data</b>	<b>24</b>
<b>CHAPTER 8. ALARMS</b>		<b>25</b>
	<b>8.1 Table of alarms</b>	<b>25</b>
<b>CHAPTER 9. PARAMETERS MANAGER</b>		<b>26</b>
<b>CHAPTER 10. WARRANTY</b>		<b>28</b>

---

---

## IMPORTANT INFORMATION

---

### Liability and residual risks

EVCO assumes no liability for any damage caused by the following (by way of example; this is not an exhaustive list):

- Installation/use for purposes other than those specified and, in particular, not adhering to the safety provisions set out by current regulations in the country in which the product is installed and/or contained in this manual;
- Use in appliances that do not guarantee sufficient protection against electric shocks, water and dust within the installation conditions created;
- Use in appliances that allow access to hazardous parts without the use of a keyed or tooled locking mechanism when accessing the instrument;
- Tampering and/or modifying the product;
- Installation/use in appliances which do not comply with current regulations in the country in which the product is installed.

The customer/manufacturer is responsible for ensuring their machine complies with these regulations.

EVCO's responsibility is limited to the correct and professional use of the product in accordance with regulations and the instructions contained in this manual and other product support documents.

To comply with EMC standards, observe all the electrical connection instructions. As it depends on the wiring configuration as well as the load and the installation type, compliance must be verified for the final machine as specified by the relevant product standard.

### Disclaimer

This document is the exclusive property of EVCO. It contains a general description and/or a description of the technical specifications for the services offered by the products listed herein. This document should not be used to determine the suitability or reliability of these products in relation to specific user applications. Each user or integration specialist should conduct their own complete and appropriate risk analysis, in addition to carrying out a product evaluation and test in relation to its specific application or use. Users can send us comments and suggestions on how to improve or correct this publication.

Neither EVCO nor any of its associates or subsidiaries shall be held responsible or liable for improper use of the information contained herein.

EVCO has a policy of continuous development. Therefore, EVCO reserves the right to make changes and improvements to any product described in this document without prior notice.

The images in this document and other documentation supplied with the product are provided for illustrative purposes only and may differ from the product itself.

The technical data in this manual is subject to change without prior notice.

### Terms and Conditions of use

#### Permitted use

The device must be installed and used in accordance with the instructions provided and, in particular, hazardous live parts must not be accessible under normal conditions.

The device must be suitably protected from water and dust with regard to its application and must also only be accessible with the aid of a tool.

Only qualified personnel may install the product or perform technical support procedures on it.

The customer must only use the product as described in the documentation relating to that product.

#### Prohibited use

Any use other than those described in the "Permitted use" section and in the product support documentation is prohibited.

**The product must be installed outside hazardous ATEX areas.**

### Disposal



The device must be disposed of in accordance with local regulations regarding the collection of electrical and electronic appliances.

### Consider the environment



With a view to respecting the environment, we strive to adhere to the environmental performance of the company, while taking account of customer requirements, technological innovations in terms of materials and the expectations of the community to which we belong. EVCO places great importance on respecting the environment, encouraging all associates to become involved with company values and guaranteeing safe, healthy and functional working conditions and workplaces.

**Please consider the environment before printing this document.**

## IMPORTANT SAFETY INFORMATION

Please read this document carefully before installation; study all the warnings before using the device. Only use the device in accordance with the methods described in this document. The following safety messages may be repeated several times in the document, to provide information regarding potential hazards or to attract attention to information which may be useful in explaining or clarifying a procedure.



This symbol is used to indicate a risk of electric shock.  
It is a safety indication and as such, should be observed to avoid potential accidents or fatalities.



This symbol is used to indicate a risk of serious personal injury.  
It is a safety indication and as such, should be observed to avoid potential accidents or fatalities.

### **DANGER**

**DANGER** indicates a situation of imminent danger which, if not avoided, **leads to death or serious injury**.

### **WARNING**

**WARNING** indicates a situation of imminent danger which, if not avoided, **may lead to death or serious injury**.

### **CAUTION**

**CAUTION** indicates a potentially hazardous situation which, if not avoided, **could cause minor or moderate injury**.

### **NOTICE**

**NOTICE** indicates a situation not related to physical injuries but which, if not avoided, **could damage the equipment**.

**NOTE:** The maintenance, repair, installation and use of electrical equipment must only be entrusted to qualified personnel.

#### **QUALIFIED PERSONNEL**

Only suitably trained and experienced personnel capable of understanding the content of this manual and all documentation regarding the product are authorised to work on and with this equipment. Furthermore, the personnel must have completed courses in safety and must be able to recognise and prevent the implied dangers. The personnel must have suitable training, knowledge and experience at a technical level, and be capable of anticipating and detecting potential risks caused by using the product, as well as changing the settings and modifying the mechanical, electric and electronic equipment for the entire system in which the product is used. All personnel working on and with the product must be entirely familiar with the relevant standards and directives, as well as safety regulations.

## SAFETY INFORMATION RELATING TO THE PRODUCT

Before carrying out any work on the equipment, read these instructions carefully, making sure you understand everything.

### DANGER

#### RISK OF ELECTRIC SHOCK, EXPLOSION OR ELECTRIC ARC

- Only suitably trained personnel, familiar with and capable of understanding the content of the manual and all relevant documentation, are authorised to work on and with this inverter. Furthermore, the personnel must have completed courses in safety and must be able to recognise and prevent the implied dangers. Installation, adjustment and maintenance must only be carried out by qualified personnel.
- Various product components, including the printed circuits, run at hazardous voltage levels.
- Only use electrically insulated and suitably calibrated measuring devices and equipment.
- Do not handle the equipment while the power supply is connected.
- Do not touch the unshielded components or the terminals while they are live.
- The motors may generate voltage if the shaft is rotated. Before carrying out any work on the inverter, lock the motor shaft to prevent it from rotating.
- Before working on the inverter:
  - Disconnect the power supply.
  - Use a suitably calibrated and electrically insulated Voltmeter to make sure the power supply is disconnected.
  - Wait for 5 minutes after disconnecting the power supply before installing/uninstalling accessories, hardware, cables or wires, to allow the condensers to discharge any residual voltage.
- Do not open, disassemble, repair or modify the product.
- Before handling the product, make sure you are wearing all the necessary personal protective equipment (PPE).
- Do not expose the equipment to liquids or chemicals.
- Before applying voltage to the inverter:
  - Make sure the running period has been completed and no parts of the system can become hazardous.
  - If the mains power supply terminals and the motor output terminals have been earthed and circuited, remove the earth and short circuits on these terminals.
  - Make sure all the equipment is properly earthed.
  - Make sure all protective elements, such as covers, hatches and grilles, are fitted and/or closed.
  - Check all wiring connections.

### DANGER

#### RISK OF ELECTRIC SHOCK AND FIRE

- Do not use the device with loads greater than those indicated in the technical data section.
- Do not exceed the temperature and humidity ranges indicated in the technical data section.
- Use the required safety interlocks (fuses and/or magnetothermal switches) of a suitable size between the power supply and the inverter.

### DANGER

#### RISK OF ELECTRIC SHOCK OR MALFUNCTIONING OF THE EQUIPMENT

Do not use damaged products or accessories.

This device was designed to operate in non-hazardous environments, excluding applications that generate, or could potentially generate, hazardous atmospheres. Only install this device in areas and for applications which are reliably free from hazardous atmospheres.

### DANGER

#### RISK OF EXPLOSION

- Only install and use this device in sites that are not at risk.
- Do not install or use this device in applications which are capable of generating hazardous atmospheres, such as applications that use flammable refrigerants.

The **Slim Power** series inverter must be installed in a suitably ventilated environment to allow heat to dissipate. The temperature of the device can exceed 80 °C (176 °F) during operation.

**⚠ WARNING**

**HOT SURFACES**

- Avoid all contact with hot surfaces.
- Do not leave flammable or heat-sensitive components on or near hot surfaces.
- Make sure the product has cooled sufficiently before handling it.
- Make sure sufficient heat dissipation takes place by performing a test under maximum load conditions.

**⚠ WARNING**

**MALFUNCTIONING OF THE EQUIPMENT**

- Perform the wiring carefully, in compliance with electromagnetic compatibility and safety requirements.
- Do not operate the product with unknown or incorrect settings or data.
- Carry out a full start-up test.
- Make sure the wiring is correct for the settings.
- Use shielded cables for all I/O signal and communication cables.
- Use double-shielded cables for motor wiring.
- Minimise the length of the connections as much as possible, to avoid winding the cables around electrically connected parts.
- The signal (communication and corresponding power supplies) and power cables for the device must be routed separately.
- Before applying the power supply, check all the wiring connections.

---

## CHAPTER 1. INTRODUCTION

---

The **Slim Power** series of inverters is designed to control asynchronous motors with a power of up to 550 W. Operating environments for this series of products are:

- Modulating fans;
- Regulation of small motors.

It uses scalar or vector motor control, depending on application requirements.

### 1.1 Compliance

**2014/35/EU:** Low voltage directive applied in accordance with standard EN61800-5-1 for electrical safety.

**2014/30/EU:** Electromagnetic compatibility directive applied in accordance with standard EN61800-3 class C2.



## CHAPTER 2. PURCHASING CODES

### 2.1 Purchasing codes table

The table below illustrates the main features of available **Slim Power** series inverters and the corresponding purchasing codes:

Features		Models		
		EI550M2L02TXVXX	EI550M2L12TXVXX	EI550M2L22TXVXX
Power supply	230 Vac $\pm$ 10 %	•	•	•
Power levels	550 W	•	•	•
Digital inputs	NPN(*)	/	1	1
Analogue inputs	0...10 V	/	/	1
Indicator LED	1 Red LED	•	•	•
	1 Green LED	•	•	•
Installation	DIN rail	•	•	•
Terminal blocks	Quick-disconnect screw type	•	•	•
Communication ports	RS-485 MODBUS SLAVE	•	/	/
FM input	Frequency modulator	/	1	/

**NOTE:** For further information, consult "**CHAPTER 3. TECHNICAL DATA**" ON PAGE 10.

(\*) = PNP on request; contact the sales office for more information.

## CHAPTER 3. TECHNICAL DATA

### 3.1 Technical specifications

Ambient operating conditions:	-10...50 °C (14...122 °F) 10 ... 90 % RH non-condensing
Transportation and storage conditions:	-20...60 °C (-4...140 °F) 10 ... 90 % RH non-condensing
Altitude:	Maximum 1000 m (3.28 ft)
Pollution category:	2
Protection degree:	IP00
Overvoltage category:	II
Power supply:	230 Vac ±10 % 50/60 Hz
Input current (RMS):	4 A
Output current (RMS):	2.3 A
Cooling method:	Natural ventilation

### 3.2 Other technical information

#### Input properties (SELV)

Digital inputs:	<b>Slim Power AI:</b> 1 digital input with clockwise/anticlockwise direction function <b>Slim Power FM / Slim Power RS-485:</b> Not present
FM input:	<b>Slim Power FM:</b> 1 input for FM modulation <b>Slim Power RS-485 / Slim Power AI:</b> Not present
Analogue inputs:	<b>Slim Power AI:</b> 1 analogue input 0...10 V <b>Slim Power FM / Slim Power RS-485:</b> Not present

#### Output properties

Motor output:	0...230 Vac, 3 phases with power supply = 230 Vac
PWM carrier frequency:	5...16 kHz
Nominal overload:	150 % for 60 seconds
Output frequency:	0...100 Hz

#### Serial communication port properties (SELV)

RS-485 serial port:	<b>Slim Power RS-485:</b> 1 opto-isolated RS-485 MODBUS RTU Slave serial port, reinforced for remote connection. Maximum baud rate: 38400 bps - Maximum cable length: 1.5 m (4.9 ft.) <b>Slim Power AI / Slim Power FM:</b> Not present
---------------------	--

#### Mechanical properties

Terminals:	<b>Motor output:</b> 6.3 mm (0.25 in.) Faston for cables with cross-section 2.5 mm <sup>2</sup> (14 AWG) <b>Power supply:</b> 6.3 mm (0.25 in.) Faston for cables with cross-section 2.5 mm <sup>2</sup> (14 AWG) <b>Analogue/Digital Inputs:</b> See " <b>SUITABLE WIRING FOR I/O SELV</b> " ON PAGE 15
------------	--

#### Cable properties:

Minimum operating temperature: 85 °C (185 °F)

#### Compliance

CE in accordance with directive EN61800-3 in category C2 and EN61800-5-1

## CHAPTER 4. MECHANICAL ASSEMBLY

### 4.1 Installation

**Slim Power** inverter installation anticipates the use of a DIN rail (TH 35 - 7.5 in accordance with IEC/EN 60715).

In particular, the safety instructions, electrical requirements and current regulations for the machine or the process in which this device is involved must be observed.

#### DANGER

##### RISK OF ELECTRIC SHOCK, EXPLOSION OR ELECTRIC ARC

- Before handling the product, make sure you are wearing all the necessary personal protective equipment (PPE).
- Do not handle the equipment while the power supply is connected.
- Do not expose the equipment to liquids or chemicals.
- Before applying voltage to the inverter:
  - Make sure the running period has been completed and no parts of the system can become hazardous.
  - If the mains power supply terminals and the motor output terminals have been earthed and circuited, remove the earth and short circuits on these terminals.
  - Make sure all the equipment is properly earthed.
  - Make sure all protective elements, such as covers, hatches and grilles, are fitted and/or closed.
- Check all wiring connections.

This device was designed to operate in non-hazardous environments, excluding applications that generate, or could potentially generate, hazardous atmospheres. Only install this device in areas and for applications which are reliably free from hazardous atmospheres.

#### DANGER

##### RISK OF EXPLOSION

- Only install and use this device in sites that are not at risk.
- Do not install or use this device in applications which are capable of generating hazardous atmospheres, such as applications that use flammable refrigerants.

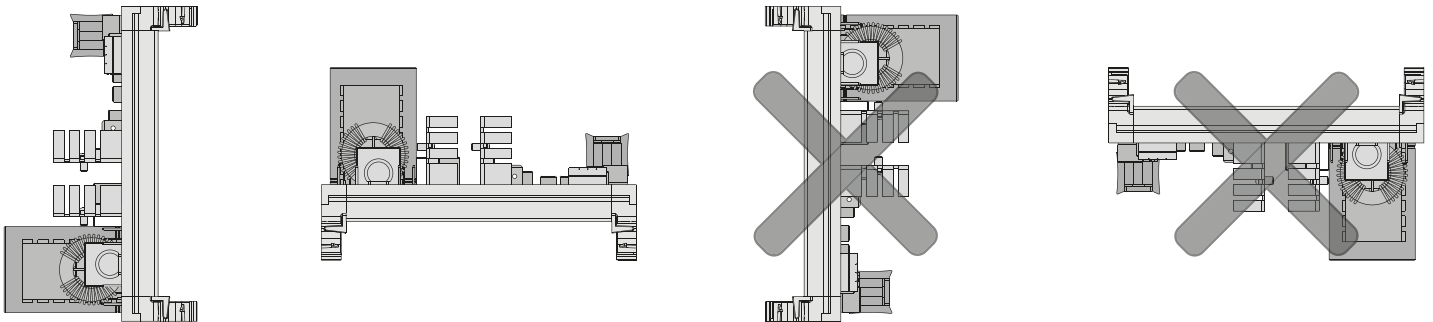

**Fig. 1.** Slim Power series inverter installation position

## 4.2 Minimum installation distances

Install the **Slim Power** inverter observing the minimum distance of 40 mm (1.57 in.) on each side, so as to guarantee adequate ventilation and aeration of the system.

### ⚠ WARNING

#### HOT SURFACES

- Avoid all contact with hot surfaces.
- Do not leave flammable or heat-sensitive components on or near hot surfaces.
- Make sure the product has cooled sufficiently before handling it.
- Make sure sufficient heat dissipation takes place by performing a test under maximum load conditions.

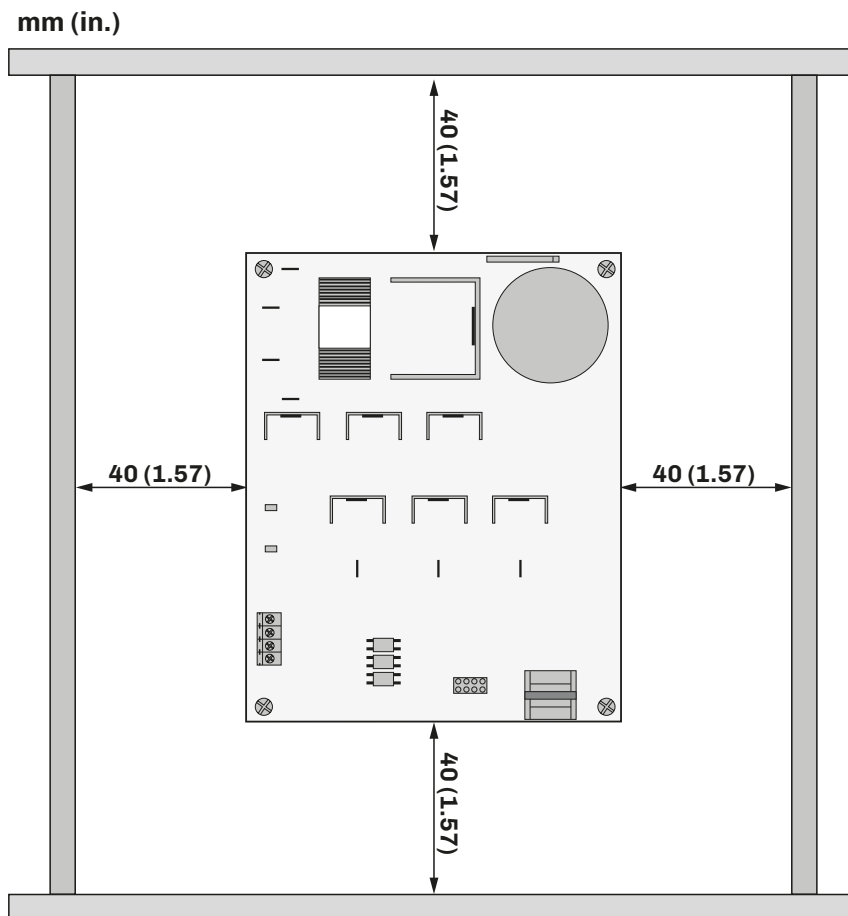

**Fig. 2.** Minimum installation distances - front view

### 4.3 Dimensions

mm (in.)

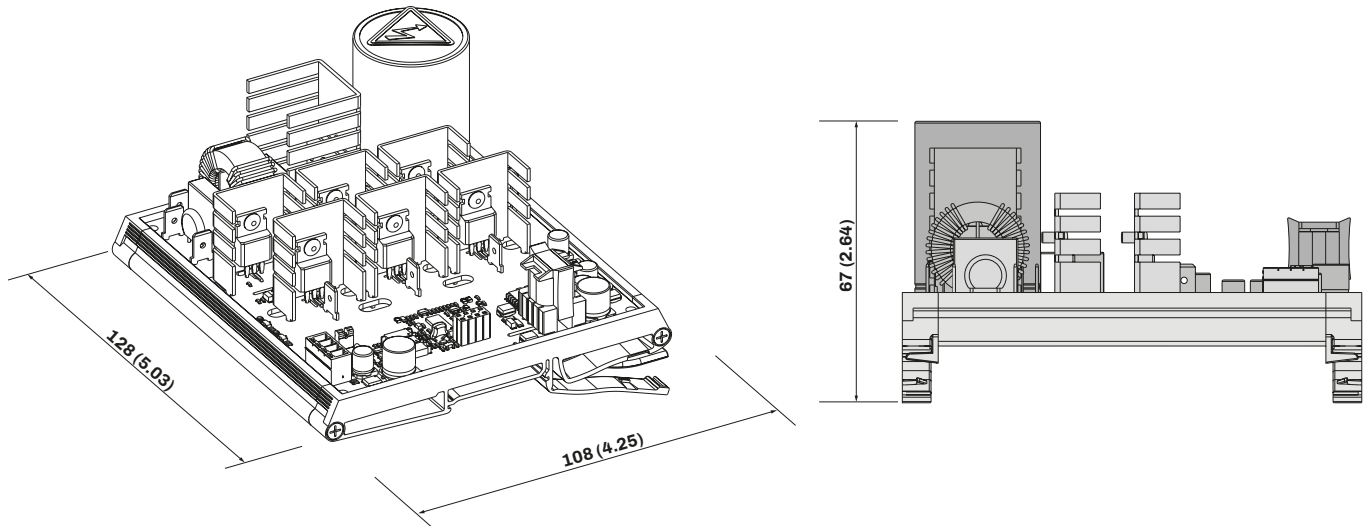

Fig. 3. Slim Power inverter dimensions

### 4.4 Installation method

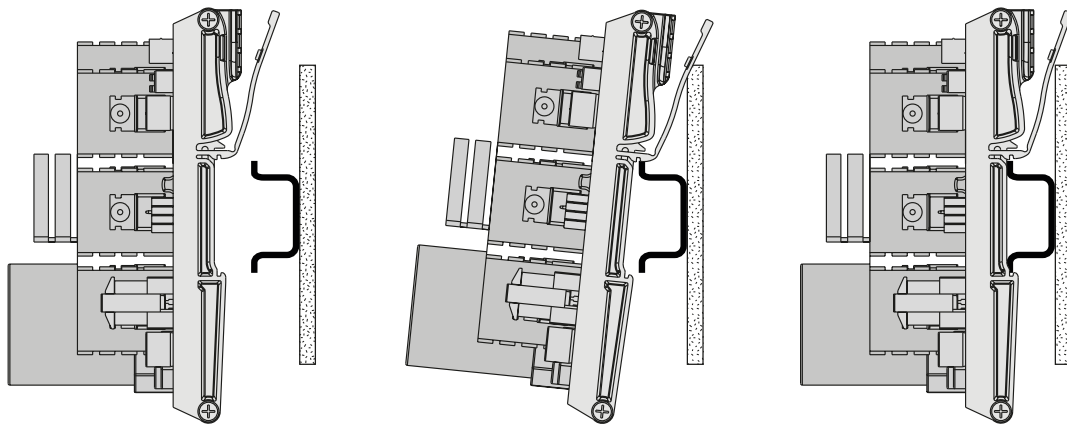

Fig. 4. Method for installing Slim Power Inverter on 4DIN rail

## CHAPTER 5. ELECTRICAL CONNECTIONS

### 5.1 Connection best practice

The following information describes the wiring guidelines and best practices which should be observed when using the inverter.

#### DANGER

##### RISK OF ELECTRIC SHOCK, EXPLOSION OR ELECTRIC ARC

- Only suitably trained personnel, familiar with and capable of understanding the content of the manual and all relevant documentation, are authorised to work on and with this inverter. Furthermore, the personnel must have completed courses in safety and must be able to recognise and prevent the implied dangers. Installation, adjustment and maintenance must only be carried out by qualified personnel.
- Various product components, including the printed circuits, run at hazardous voltage levels.
- Only use electrically insulated and suitably calibrated measuring devices and equipment.
- Do not handle the equipment while the power supply is connected.
- Do not touch the unshielded components or the terminals while they are live.
- The motors may generate voltage if the shaft is rotated. Before carrying out any work on the inverter, lock the motor shaft to prevent it from rotating.
- Before working on the inverter:
  - Disconnect the power supply.
  - Use a suitably calibrated and electrically insulated Voltmeter to make sure the power supply is disconnected.
  - Wait for 5 minutes after disconnecting the power supply before installing/uninstalling accessories, hardware, cables or wires, to allow the condensers to discharge any residual voltage.
- Do not open, disassemble, repair or modify the product.
- Before handling the product, make sure you are wearing all the necessary personal protective equipment (PPE).
- Do not expose the equipment to liquids or chemicals.
- Before applying voltage to the inverter:
  - Make sure the running period has been completed and no parts of the system can become hazardous.
  - If the mains power supply terminals and the motor output terminals have been earthed and circuited, remove the earth and short circuits on these terminals.
  - Make sure all the equipment is properly earthed.
  - Make sure all protective elements, such as covers, hatches and grilles, are fitted and/or closed.
- Check all wiring connections.

#### DANGER

##### RISK OF ELECTRIC SHOCK AND FIRE

- Do not use the device with loads greater than those indicated in the technical data section.
- Do not exceed the temperature and humidity ranges indicated in the technical data section.
- Use the required safety interlocks (fuses and/or magnetothermal switches) of a suitable size between the power supply and the inverter.
- Only use cables with a suitable cross-section as indicated in the section "Wiring best practices".

When the inverter is in standby and the motor is not running, the latter remains live.

#### DANGER

##### RISK OF ELECTRIC SHOCK

Do not handle the motor when the inverter is in standby.

### 5.1.1 Wiring best practices

When wiring the equipment, observe the following instructions:

- The I/O and communication wiring must be kept separate from the power supply wiring. These two types of wiring must be routed in separate ducts.
- Make sure the operating environment and conditions fall within the specified values.
- Use wires with the correct diameter, suited to the voltage and current requirements.
- Use copper conductors (compulsory).
- Use shielded twisted pair cables for analogue I/O connections (**Slim Power AI / Slim Power FM** models only).
- Use shielded twisted pair cables for network and RS-485 serial connections (**Slim Power RS-485** model only).

Use correctly earthed shielded cables for all inputs or analogue outputs, for communication connections and for motor wiring.







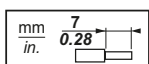

## ⚠ WARNING

### MALFUNCTIONING OF THE EQUIPMENT

- Perform the wiring carefully, in compliance with electromagnetic compatibility requirements.
- Carry out a full start-up test.
- Make sure the wiring is correct for the settings.
- Use shielded cables for all I/O signal and communication cables.
- Use double-shielded cables for motor wiring.
- Minimise the length of the connections as much as possible, to avoid winding the cables around electrically connected parts.
- The signal (communication and corresponding power supplies) and power cables for the device must be routed separately.
- Before applying the power supply, check all the wiring connections.

### Suitable wiring for I/O SELV

Step 3.5 mm (0.137 in.)

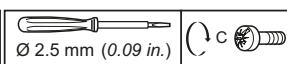
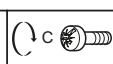
									 Ø 2.5 mm (0.09 in.)	 N•m 0.22...0.25 lb-in 1.94...2.21
	mm <sup>2</sup>	0.14...1.5	0.14...1.5	0.25...1.5	0.25...0.5	2 x 0.08...0.5	2 x 0.08...0.5	2 x 0.25...0.34		
AWG	28...16	28...16	22...16	22...20	2 x 28...20	2 x 28...20	2 x 22...21	2 x 20...20		

**Fig. 5.** Suitable wiring for I/O SELV

## 5.2 Wiring diagrams

### 5.2.1 Slim Power FM

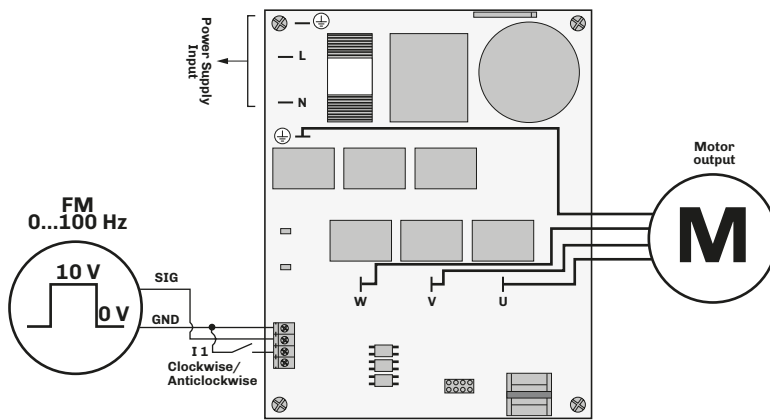

TERMINALS	
L	PHASE - Power supply input
N	NEUTRAL - Power supply input
PE	EARTH - Power supply input (*)
U	Motor control output
V	Motor control output
W	Motor control output
PE	Motor earth connection (*)
I1	Digital input 1(Clockwise/Anticlockwise)
GND	Frequency modulator GND reference Digital input common
SIG	Frequency modulator signal input

(\*) NOTE: For board and motor output earthing, see paragraph "5.2.4 EARTHING" ON PAGE 17.

### 5.2.2 Slim Power RS-485

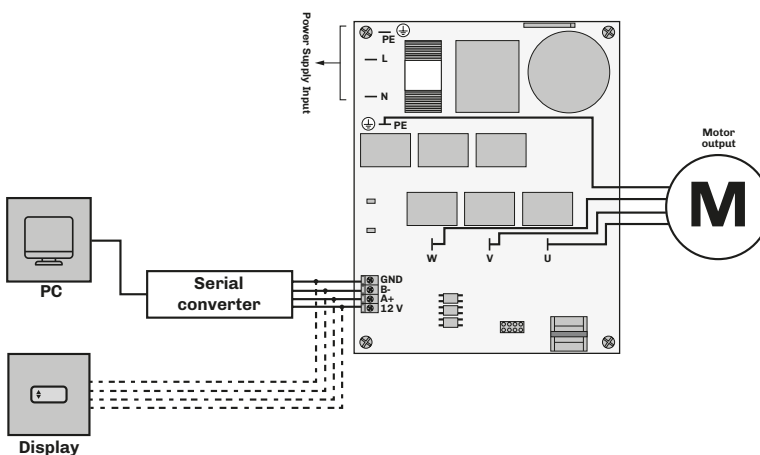

TERMINALS	
L	PHASE - Power supply input
N	NEUTRAL - Power supply input
PE	EARTH - Power supply input (*)
U	Motor control output
V	Motor control output
W	Motor control output
PE	Motor earth connection (*)
GND	RS-485 serial port for remote connection
B-	
A+	
12 V	

(\*) NOTE: For board and motor output earthing, see paragraph "5.2.4 EARTHING" ON PAGE 17.

### 5.2.3 Slim Power AI

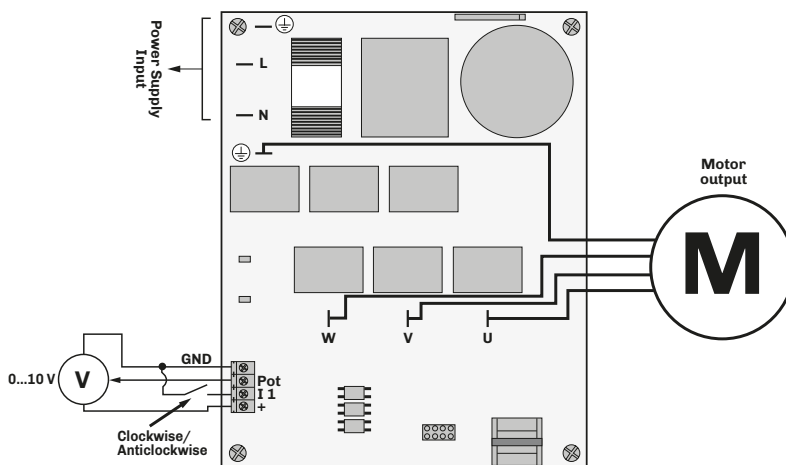

TERMINALS	
L	PHASE - Power supply input
N	NEUTRAL - Power supply input
PE	EARTH - Power supply input (*)
U	Motor control output
V	Motor control output
W	Motor control output
PE	Motor earth connection (*)
I1	Digital input 1(Clockwise/Anticlockwise)
COM	Digital input common
-	Analogue input for potentiometer with 10 Vdc power supply
Pot	
+	

(\*) NOTE: For board and motor output earthing, see paragraph "5.2.4 EARTHING" ON PAGE 17.



#### 5.2.4 Earthing

  **DANGER**

**RISK OF ELECTRIC SHOCK, EXPLOSION OR ELECTRIC ARC**

Make sure all the equipment is properly earthed.

The inverter may have a dispersion current to earth that is greater than 3.5 mA.

  **DANGER**

**RISK OF ELECTRIC SHOCK AND FIRE**

Use correctly sized differentials on the earth line.

---

## CHAPTER 6. OPERATION

---

The **Slim Power** inverter controls asynchronous motors by powering variable frequency windings. The maximum switching frequency is 16 kHz.

### 6.1 Control types

Depending on the field of application, parameter **S103** can be used (**Slim Power RS-485** series only) to choose one of the following control types:

- Scalar control (V/f) with an open loop, or
- Sensorless vector control.

### 6.2 Protection

The inverter is protected against:

- Overcurrent;
- Overvoltage;
- Undervoltage;
- Overload, or
- Overtemperature (the inverter automatically reduces the PWM carrier in the event of overtemperature).

For more details on these and other faults, please refer to "**CHAPTER 8. ALARMS**" ON PAGE 25.

### 6.3 LED

The LEDs on the board:

- If lit in Green: Inverter in RUN status;
- If lit in RED: Inverter in STOP status (Standby);
- If lit in Red and Green at the same time: Safe Start Enabled;
- If flashing in Red: Inverter in Alarm (see Alarms chapter).

### 6.4 AUTO-RESET function

The alarm AUTO-RESET function can be set via parameters **S104** and **S105** (**Slim Power RS-485** series only). If enabled, this function ensures that the alarms are automatically reset after the time set in parameter **S105**.

### 6.5 SAFE START function

If you set parameter

- **S106** = 1 (only applicable in the **Slim Power RS-485** series);

The Safe Start function is enabled (if **S106** = 0, the function is disabled).

When Safe Start is enabled, and the inverter is powered, automatic start-up of the motor with the input enabled will be avoided and it will be necessary to provide another start-up input for motor start-up.

## CHAPTER 7. PARAMETERS

RS-485 model **Slim Power** series inverter parameters can be configured using **Parameters Manager**, by connecting the inverter to the PC via RS-485 serial port. This means **Slim Power** series inverters are fully configurable according to your own requirements/applications.

In **Slim Power AI** and **Slim Power FM** inverters the parameters cannot be changed; contact technical support for further information.

**NOTE:** For PC - **Slim Power RS-485** series inverter connection, use an RS-485/USB converter (for example, p/n: **EVIF20SUXI**); for all necessary information on the subject, please refer to instruction sheet code **104SUXIA104**).

The parameters are divided into groups.

### Description of columns in the Table of Parameters

- **Par.:** List of configurable device parameters;
- **Description:** Indicates parameter operation and any possible selections;
- **MU:** Measurement unit relating to the parameter;
- **Range:** Describes the interval of values that the parameter can assume. This can be correlated with other instrument parameters (indicated with the parameter code).  
**NOTE:** if the actual value is outside the permitted limits for that parameter (for example, because other parameters defining the aforementioned limits have been altered), the value of the violated limit is displayed instead of the actual value;
- **Default:** Indicates the pre-set factory configuration;
- **PW:** Indicates the access level for the parameter.
- **Modbus address:** Indicates the address of the Modbus register containing the resource you want to access.

### 7.1 Table of Slim Power RS-485 configuration parameters

Par.	Description	MU	Range	Default	PW	Modbus address
<b>Control GROUP S1-</b>						
<b>S103</b>	Selection of control type applied to the motor <b>1</b> = Scalar; <b>2</b> = Vector.	-	1 ... 2	1	C	103
<b>S104</b>	Autoreset selection. Indicates the number of automatic alarm resets with the exception of AI, EP (see " <b>CHAPTER 8. ALARMS</b> " ON PAGE 25). <b>0</b> = Disabled.	-	0 ... 99	0	C	104
<b>S105</b>	Automatic alarm reset delay time.	s	0.1 ... 120.0	5.0	U	105
<b>S106</b>	Enable/Disable the Safe Start function. <b>0</b> = Function disabled; <b>1</b> = Function enabled.	-	0 ... 1	0	U	106
<b>S107</b>	Mains power failure management. <b>0</b> = No restart; <b>1</b> = Restart after failure < 5 s; <b>2</b> = Restart after failure ≥ 5 s.	-	0...2	0	U	670
<b>Speed GROUP S2-</b>						
<b>S201</b>	Nominal target speed. If <b>S101</b> = 2, 4 or 5, the nominal speed is set.	rpm	<b>S205</b> ... <b>S204</b>	1000	U	201
<b>S202</b>	Acceleration ramp. Time required to reach the nominal speed from 0 rpm.	s	0.2 ... 200.0	3.0	U	202
<b>S203</b>	Deceleration ramp. Time required to reach 0 rpm from the nominal speed.	s	0.2 ... 200.0	5.0	U	203
<b>S204</b>	Maximum motor speed <sup>(1)</sup> .	rpm	<b>S205</b> ... 6000	1800	U	204
<b>S205</b>	Minimum motor speed <sup>(1)</sup> .	rpm	150 ... <b>S204</b>	300	U	205
<b>S206</b>	Select the motor rotation direction <sup>(2)</sup> . <b>0</b> = Clockwise; <b>1</b> = Anti-clockwise.	-	0 ... 1	0	A	206
<b>S212</b>	Torque reference. Torque threshold for activating the opposite motor rotation direction. <b>0.0</b> = Disabled.	Nm	0.0 ... <b>S507</b>	0.0	U	212
<b>S213</b>	Number of opposite rotation attempts. Select the number of attempts permitted with the opposite motor rotation direction. <b>0</b> = No attempt.	-	0 ... 20	0	U	213
<b>S214</b>	Opposite rotation duration. Duration of the opposite motor rotation.	s	1 ... 200	5	U	214
<b>S215</b>	Speed jump 1.	rpm	<b>S205</b> ... <b>S204</b>	300	U	215
<b>S216</b>	Speed jump 2.	rpm	<b>S205</b> ... <b>S204</b>	300	U	216
<b>S217</b>	Speed jump band. Interval size for target speeds to be jumped. <b>0</b> = Disabled.	rpm	0 ... <b>S205</b>	0	U	217

Par.	Description	MU	Range	Default	PW	Modbus address
<b>Inputs/Outputs GROUP S3..</b>						
<b>S301</b>	Minimum analogue reference value. Selection of the minimum potentiometer voltage.	V	0.00 ... <b>S302</b>	0.00	C	301
<b>S302</b>	Maximum analogue reference value. Selection of the maximum potentiometer voltage.	V	<b>S301</b> ... 10.00	10.00	C	302
<b>S304</b>	Digital input 1 function. <b>0</b> = Disable; <b>1</b> = Enable; <b>2</b> = Stop/Run; <b>3</b> = Pulsed run; <b>4</b> = Pulsed stop; <b>5</b> = Clockwise/anti-clockwise direction; <b>6</b> = Stop/Run clockwise; <b>7</b> = Stop/Run anti-clockwise; <b>8</b> = Reset alarm; <b>9</b> = User alarm; <b>10</b> = Multi-speed 1; <b>11</b> = Multi-speed 2; <b>12</b> = Reserved; <b>13</b> = Motor potentiometer with input up; <b>14</b> = Motor potentiometer with input down; <b>15</b> = Reserved; <b>16</b> = Reserved; <b>17</b> = Motor thermal switch; <b>18</b> = Frequency tracking (FM). <b>19...40</b> = Reserved.	-	0 ... 40	0	C	304
<b>S305</b>	Digital input 2 function. Same as <b>S304</b> .	-	0 ... 40	0	C	305
<b>Modbus GROUP S4..</b>						
<b>S401</b>	Modbus communication protocol device address.	-	1 ... 247	1	A	401
<b>S402</b>	Baud rate. Transmission speed. <b>1</b> = 9600; <b>2</b> = 19200; <b>3</b> = 38400.	Baud	1 ... 3	1	A	402
<b>S403</b>	Time limit beyond which, if communication is not working, the device enters timeout alarm (TO) mode. <b>0</b> = Disabled.	s	0.0 ... 60.0	2.0	A	403
<b>S404</b>	Modbus protocol (bit/parity/stop bit). <b>0</b> = 8/None/1; <b>1</b> = 8/odd/1; <b>2</b> = 8/even/1; <b>3</b> = 8/None/2; <b>4</b> = 8/odd/2; <b>5</b> = 8/even/2. <b>NOTE:</b> Parameters manager does not manage protocols with 2 stop bits.	-	0...5	2	A	404
<b>Motor Group S5...</b>						
<b>S501</b>	Nominal motor current <sup>(4)</sup> .	A	0.1 ... <b>S601</b>	2.7	C	501
<b>S502</b>	Nominal motor voltage <sup>(4)</sup> .	V	50 ... 400	230	C	502
<b>S503</b>	Nominal motor frequency <sup>(4)</sup> .	Hz	0 ... 100	50	C	503
<b>S504</b>	Number of pole pairs <sup>(4)</sup> .	-	1 ... 8	2	C	504
<b>S505</b>	No-load current <sup>(4)</sup> .	A	0.1 ... <b>S501</b>	1.4	C	505
<b>S506</b>	Nominal motor revolutions <sup>(4)</sup> .	rpm	1 ... 3000	1370	C	506
<b>S507</b>	Nominal torque <sup>(4)</sup> .	Nm	0.1 ... 100	3.8	C	507
<b>S508</b>	Cos(phi). Nominal motor power factor <sup>(4)</sup> .	-	0.01 ... 1.00	0.75	C	508
<b>S509</b>	Motor boost. Overvoltage percentage applied at motor start-up.	%	0 ... 25	5	C	509
<b>S510</b>	Motor voltage. Maximum voltage percentage applied to the motor in relation to the nominal value.	%	10 ... 112	100	C	510
<b>S511</b>	Motor overload. Motor overload percentage permitted by the inverter for a time set using parameter <b>S512</b> .	%	0 ... 50	50	C	511
<b>S512</b>	Maximum overload time.	s	0 ... 60	30	C	512

Par.	Description	MU	Range	Default	PW	Modbus address
<b>S513</b>	Stop type. <b>0</b> = Coast-to-stop; <b>1</b> = Stop with ramp; <b>2</b> = Stop with DC voltage injection; <b>3</b> = Stop with ramp + DC voltage injection. The latter creates a ramp until the braking speed is reached, and then DC voltage is injected in the percentage set via parameter <b>S516</b> for a duration equal to <b>S515</b> , finally cutting off the motor power supply <sup>(5)</sup> . <b>NOTE: in alarm or emergency conditions, stoppage is always the free type.</b>	-	0 ... 3	1	C	513
<b>S514</b>	Speed at which to start braking in DC voltage. Only applies when <b>S513</b> = 3.	rpm	0 ... <b>S205</b>	0	C	514
<b>S515</b>	DC voltage braking duration. Only applies when <b>S513</b> = 2 or 3.	s	0.0 ... 20.0	0.0	C	515
<b>S516</b>	DC bus voltage percentage applied to the motor during braking with DC voltage. Only applies when <b>S513</b> = 2 or 3.	%	0 ... 50	0	C	516
<b>S518</b>	Scale factor for torque display.	-	1 ... 9999	200	C	518
<b>S520</b>	Stator resistance.	Ω	0.00 ... 99.99	6.80	C	520
<b>S525</b>	Rotor time constant.	ms	0 ... 9999	232	C	525
<b>S526</b>	WTS. Parameter calculated by autotuning.	-	0 ... 5000	2291	C	526
<b>S527</b>	KM. Parameter calculated by autotuning.	-	0 ... 16000	13890	C	527
<b>S529</b>	Selection of PWM carrier frequency.	kHz	5 ... 16	5	C	529
<b>S530</b>	Kp for current loop. Proportional gain for the PI current controller.	%	1 ... 1000	400	C	530
<b>S531</b>	Ki for current loop. Integral action time for the PI current controller.	ms	0 ... 1000	10	C	531
<b>S532</b>	Kp for speed loop. Proportional gain for the PI speed controller.	%	1 ... 1000	400	C	532
<b>S533</b>	Ki for speed loop. Integral action time for the PI speed controller.	s	0.00...10.00	1.00	C	533
<b>S534</b>	Motor phase loss alarm sensitivity. Indicates the motor phase loss alarm sensitivity percentage. <b>0</b> = disabled; <b>100</b> = maximum sensitivity.	%	0 ... 100	0	C	534
<b>S535</b>	Motor stall alarm sensitivity. Indicates the motor stall alarm sensitivity percentage. <b>0</b> = disabled; <b>100</b> = maximum sensitivity.	%	0 ... 100	0	C	535
<b>Inverter GROUP S6..</b>						
<b>S601</b>	Maximum current that the inverter can supply to the motor during its operation <sup>(6)</sup> .	A	0.1 ... 5.0	4.2	R	601
<b>S602</b>	Undervoltage level. Voltage value under which the Undervoltage (UV) error is generated.	V	120 ... <b>S603</b>	200	R	602
<b>S603</b>	Overvoltage level. Voltage value over which the Overvoltage (OV) error is generated.	V	<b>S602</b> ... 450	420	R	603
<b>S605</b>	Board alarm temperature (CPU).	°C	50 ... 100	95	R	605
<b>S606</b>	Cooler alarm temperature.	°C	50 ... 100	95	R	606
<b>S607</b>	Enable PWM carrier derating. Enables derating with PWM carrier above 5 kHz. <b>0</b> = Disabled; <b>1</b> = Enabled.	-	0 ... 1	1	R	607
<b>Access GROUP S9..</b>						
<b>S901</b>	Advanced passwords.	-	0 ... 9999	1259	A	901
<b>S902</b>	Manufacturer password.	-	0 ... 9999	4783	C	902
<b>S903</b>	Reserved password.	-	0 ... 9999	6278	R	903
<b>NOTE: No password is required to access the User level (U).</b>						
<sup>(1)</sup> The minimum and maximum limits are calculated based on the number of pole pairs for the motor, between 5 and 100 Hz;						
<sup>(2)</sup> Looking at the motor with the shaft positioned to the front;						
<sup>(3)</sup> By combining two of the three inputs available, you can obtain 4 speed targets; See parameters <b>S304..S306</b> in paragraph "7.1 TABLE OF SLIM POWER RS-485 CONFIGURATION PARAMETERS" ON PAGE 19;						
<sup>(4)</sup> Parameter depends on the motor rating label data;						
<sup>(5)</sup> In alarm or emergency conditions, stoppage is always the free type;						
<sup>(6)</sup> Parameter depends on the inverter model.						

## 7.2 Table of Modbus commands

The commands implemented are:

Command	Description
03	Read holding registers (maximum 16 registers)
06	Write single holding register
16	Write multiple holding registers (maximum 16 registers)

## 7.3 Serial communication settings

The **Slim Power RS-485** inverter communicates via serial port with the following settings:

- 8 bit;
- Even Parity;
- 1 stop bit;
- Baud rate set via parameter: **S402**.

## 7.4 Table of Modbus variables

Address	Parameter name	R/W	Description
980	Status word	R	<p>Read only, indicates the inverter operating status:</p> <p><b>Bit 0 = Ready</b>  <b>1</b> = Inverter ready to receive commands;  <b>0</b> = Inverter in alarm or not ready to receive commands;</p> <p><b>Bit 1 = Run</b>  <b>1</b> = Motor in motion;  <b>0</b> = Motor stopped;</p> <p><b>Bit 2 = Acceleration</b>  <b>1</b> = Motor in acceleration;  <b>0</b> = Motor not in acceleration;</p> <p><b>Bit 3 = Deceleration</b>  <b>1</b> = Motor in deceleration;  <b>0</b> = Motor not in deceleration;</p> <p><b>Bit 4 = Alarm</b>  <b>1</b> = Inverter in alarm;  <b>0</b> = Inverter not in alarm;</p> <p><b>Bit 5 = Overload</b>  <b>1</b> = Power exceeded 100 %;  <b>0</b> = Power dropped below 100 %;</p> <p><b>Bit 6 = Safe start</b>  <b>1</b> = Inverter in safe start;  <b>0</b> = Inverter normal;</p> <p><b>Bit 7 = Direction</b>  <b>1</b> = Clockwise;  <b>0</b> = Anticlockwise;</p> <p><b>Bit 8 = Target</b>  <b>1</b> = Target speed reached;  <b>0</b> = Target speed not reached;</p> <p><b>Bit 9 = Power off (PWOff)</b>  <b>1</b> = Inverter in power off;  <b>0</b> = Normal;</p> <p><b>Bit 10 = PWM derating</b>  <b>1</b> = Derating enabled;  <b>0</b> = Normal;</p> <p><b>Bit 14..Bit 15 = Parameter access level</b>  <b>00</b> = User;  <b>10</b> = Advanced;  <b>01</b> = Manufacturer;  <b>11</b> = Reserved.</p>

Address	Parameter name	R/W	Description
981	Alarm word	R	Read only, indicates active alarms: <b>Bit 0</b> = Undervoltage (UV); <b>Bit 1</b> = Overvoltage (OV); <b>Bit 2</b> = Overcurrent (OC); <b>Bit 3</b> = Overload (OL); <b>Bit 4</b> = Device overtemperature (BT); <b>Bit 5</b> = Motor overtemperature (OT); <b>Bit 6</b> = Analogue input (AI); <b>Bit 7</b> = Data Eeprom (EP); <b>Bit 8</b> = Communication timeout (TO); <b>Bit 9</b> = Reserved; <b>Bit 11</b> = Motor phase loss (PL); <b>Bit 12</b> = Reserved; <b>Bit 13</b> = Motor stall (MS).
982	Target speed	R	Target speed set for the motor (equal to monitor parameter "nr").
983	Motor frequency	R	Motor output frequency (equal to monitor parameter "Fo").
984	Motor revolutions	R	Motor output speed (equal to monitor parameter "no").
985	Set target speed	R/W	Sets the target speed setting for the motor.
986	Command word	R/W	Reading and writing, indicates the possible commands: <b>Bit 0</b> = Start <b>1</b> = Motor start command; <b>0</b> = No function;  <b>Bit 1</b> = Direction <b>1</b> = Clockwise; <b>0</b> = Anticlockwise.  <b>Bit 2</b> = Reserved;  <b>Bit 4</b> = Reset Alarms <b>1</b> = Reset active alarms; <b>0</b> = No function;  <b>Bit 5</b> = Default <b>1</b> = Restore default parameters; <b>0</b> = No function;  <b>Bit 6</b> = Saving <b>1</b> = Save parameters in Eeprom; <b>0</b> = No function;  <b>Bit 7</b> = Inverter restart <b>1</b> = Full inverter restart; <b>0</b> = No function;
987	Password	R/W	Password for changing parameters at the desired level.

## 7.5 Table of monitor data

Abbreviation	Description	R/W	Modbus address
<b>nr</b>	Target speed (rpm) Displays the target speed set for the motor.	R	1
<b>Fo</b>	Frequency (Hz) Displays the motor output frequency.	R	2
<b>Io</b>	RMS current (A) Displays the motor output RMS current.	R	3
<b>Vo</b>	Motor voltage (V) Displays the motor output voltage.	R	4
<b>no</b>	Revolutions (in rpm) Displays the estimated output revolutions for the motor.	R	5
<b>T</b>	Torque (N) Displays the motor output torque.	R	6
<b>pf</b>	Power factor Displays the estimated motor output power factor value.	R	7
<b>dir</b>	Rotation direction Displays the direction of the motor revolutions. <b>0</b> = Clockwise; <b>1</b> = Anti-clockwise.	R	8
<b>vdc</b>	DC bus voltage (V) Displays the DC Bus voltage for the inverter.	R	9
<b>Ti</b>	Device temperature (°C) Displays the inverter temperature.	R	10
<b>Te</b>	Cooler temperature (°C) Displays the temperature of the cooler.	R	11
<b>Ai</b>	Analogue Input (V) Displays the voltage value of the signal from the potentiometer, if applicable.	R	12
<b>Di</b>	Digital input Displays the status of the digital inputs. <b>XXX</b> = I1 I2 I3 = 0/1 0/1 0/1.	R	13
<b>Do</b>	Reserved	R	14
<b>Pm</b>	Power (%) Displays an estimate for the mechanical power.	R	15
<b>Alm0</b>	Last alarm Displays the code for the last alarm that took place <sup>(1)</sup> .	R	16
<b>Alm1</b>	Penultimate alarm Displays the code for the penultimate alarm that took place <sup>(1)</sup> .	R	17
<b>Alm2</b>	Third last alarm Displays the code for the third last alarm that took place <sup>(1)</sup> .	R	18
<b>Ih</b>	Run time (h) Displays the total time for which the device has been on.	R	19
<b>Mh</b>	Motor run time (h) Displays the total time for which the motor has been running.	R	20

<sup>(1)</sup>See "Alarms" chapter for possible alarm codes shown after "**Alm0, Alm1, Alm2**"



## CHAPTER 8. ALARMS

The table below lists alarms with corresponding solutions. The main consequence of each alarm is that the device switches off.

### 8.1 Table of alarms

Code	Description	No. of red LED flashes	Cause	Alarm solution
<b>UV</b>	Undervoltage alarm	1	The voltage value of the device has dropped below the minimum value set via parameter <b>S602</b>	Reset alarm from governing input or automatically with the AUTORESET function when enabled
<b>OV</b>	Overvoltage alarm	2	The voltage value of the device has exceeded the maximum value set via parameter <b>S603</b>	
<b>OC</b>	Overcurrent alarm	3	The device has exceeded the maximum current value set via parameter <b>S601</b>	
<b>OL</b>	Overload alarm	4	When the amount of energy according to logic <b>I*t</b> exceeds the value set via parameters <b>S511</b> and <b>S512</b>	
<b>BT</b>	Electronics board overtemperature alarm	5	The device has exceeded the temperature threshold <b>S605</b>	The alarm resets automatically if: $T_i = S605 - 10\text{ °C}$
<b>OT</b>	Cooler overtemperature alarm	6	The motor has exceeded the temperature threshold <b>S606</b>	The alarm resets automatically if: Motor temperature = <b>S606 - 10 °C</b>
<b>AI</b>	Analogue input alarm	7	Analogue input not working	Contact EVCO technical support
<b>EP</b>	Eeprom data alarm	8	The data structure is not intact	The default values are restored automatically. Any changes to the parameters map will be irreversibly lost and will have to be carried out again manually
<b>TO</b>	Communication timeout alarm	9	MODBUS communication interrupted	Check the connection
<b>PS</b>	Phase loss alarm	12	<ul style="list-style-type: none"> <li>• Motor not connected correctly</li> <li>• Incorrect <b>S534</b> sensitivity</li> </ul>	<ul style="list-style-type: none"> <li>• Check the power supply wiring;</li> <li>• Change parameter <b>S534</b>.</li> </ul>
<b>MS</b>	Motor stall alarm	14	<ul style="list-style-type: none"> <li>• Motor does not rotate properly with vector algorithm;</li> <li>• Incorrect <b>S535</b> sensitivity.</li> </ul>	<ul style="list-style-type: none"> <li>• Make sure parameters <b>S500...S527</b> are correct;</li> <li>• Change parameter <b>S535</b>.</li> </ul>

## CHAPTER 9. PARAMETERS MANAGER

The **Slim Power RS-485** inverter can be configured using **Parameters Manager**, available to download from the web address: <https://www.evco.it/it/15894-parameters-manager>.

To connect the inverter to a PC, an RS-485/USB converter must be used (p/n: **EVIF20SUXI**).

**NOTE:** For all necessary information on the subject, please refer to the instruction sheet p/n **104SUXIA104**

**NOTE:** Make sure you have downloaded the latest version of the drivers available for **Parameters Manager**.

Once you have started **Parameters Manager**, you will need to configure the settings correctly to connect to the **Slim Power RS-485** as shown in the image below:

### WARNING

#### MALFUNCTIONING OF THE EQUIPMENT

- Only update inverter parameters while the motor is off.
- Do not perform any communication serial port wiring procedures while the motor is on and the inverter powered.

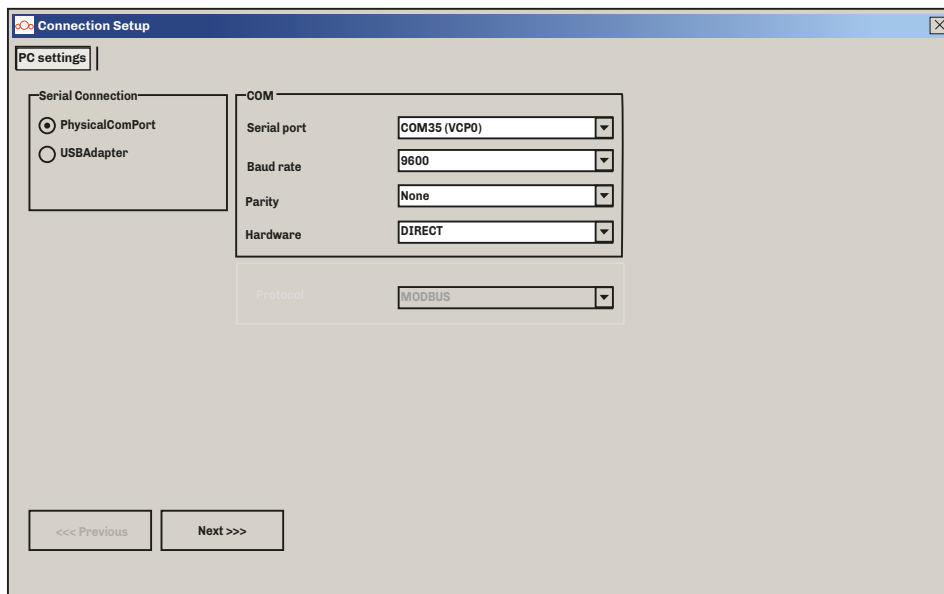

**Fig. 6.** Communication port setting

Press **NEXT** to continue and configure the network scan settings:

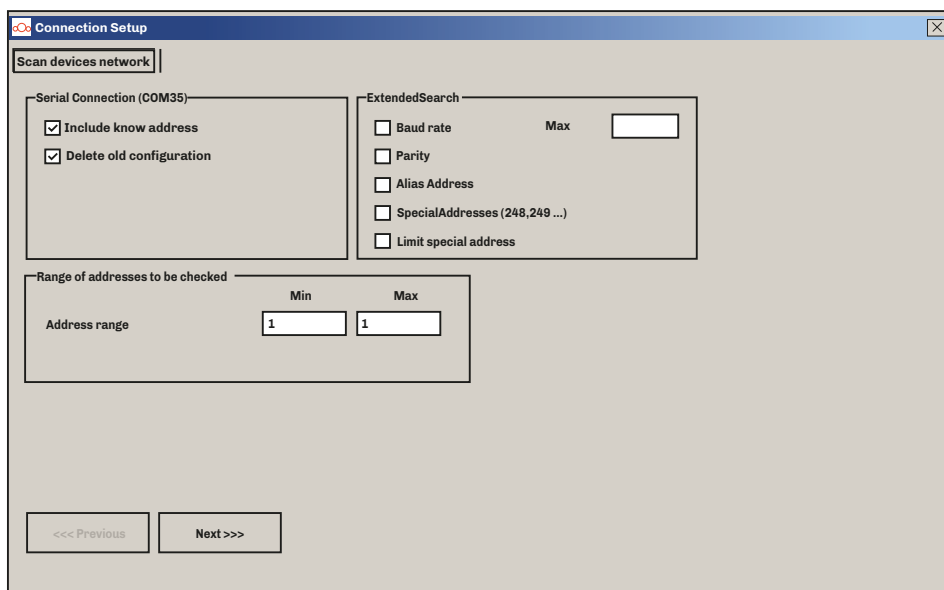

**Fig. 7.** Communication Modbus address setting

If **Parameters Manager** detects the **Slim Power RS-485** inverter in the network, the following screen will appear, otherwise you will have to reconfigure the previous settings.

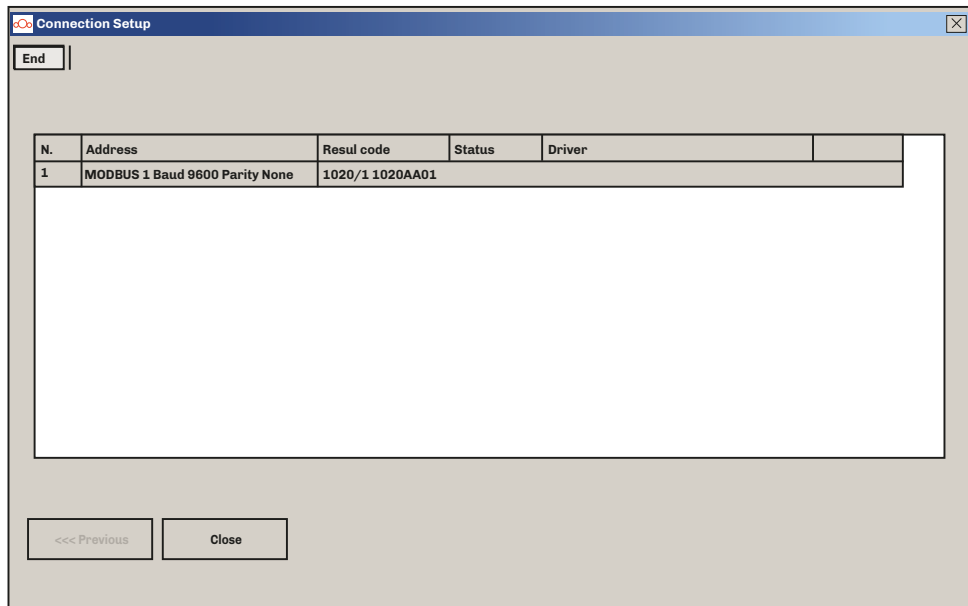

**Fig. 8. Slim Power RS-485 Inverter detection**

Press **Close** to proceed with the **Slim Power RS-485** inverter parameter configuration screen.

**EVCO S.p.A.**

Via Feltre 81, 32036 Sedico (BL) ITALY

| **Telephone:** +39 0437 8422  
| **Fax:** +39 0437 83648  
| **email:** info@evco.it  
| **Web:** [www.evco.it](http://www.evco.it)

This document and the solutions contained within it are the intellectual property of EVCO, safeguarded by the Italian Industrial Property Code (CPI). EVCO forbids the reproduction and distribution, even in part, of the contents, unless express authorisation is obtained directly from EVCO. The customer (manufacturer, installer or end user) assumes all responsibility for device configuration. EVCO does not assume any responsibility for potential errors and reserves the right to make any changes, at any time, without the basic functional and safety-related features being affected.