



c-pro 3 NODE kilo AHU

PROGRAMMABLE CONTROLLERS FOR AIR HANDLING UNITS



ENGLISH

APPLICATION MANUAL version 1.0

CODE 144CP3NKAHE104

Important

Important

Read this document thoroughly before installation and before use of the device and follow all recommendations; keep this document with the device for future consultation.

The following symbols support reading of the document:

💡 Indicates a suggestion

⚠ Indicates a warning.

The device must be disposed of in compliance with local Standards regarding the collection of electric and electronic equipment.



Index

1	GENERALITIES.....	6
1.1	Description.....	6
2	Dimensions	7
2.1	Dimensions controller	7
2.2	Dimensions remote user interface	7
2.3	Installation remote user interface.....	8
3	User interface	10
3.1	Remote user interface <i>Vroom</i>	10
3.2	Display that can be viewed from the <i>Vroom</i> interface	11
4	List of pages.....	12
4.1	Password	13
4.2	Main page	13
4.2.1	Status pages.....	13
4.2.2	(TIME BANDS) screen	14
4.2.3	Fans Screen	15
4.2.4	Regulation status of coil 1 screen.....	15
4.2.5	Regulation status of coil 2 screen.....	15
4.2.6	Direct expansion coil regulation status screen	16
4.2.7	Heating elements status screen	16
4.2.8	Humidity regulation status screen.....	16
4.2.9	Status screen of the damper for air circulation	17
4.2.10	Heat recovery status screen.....	17
4.2.11	Circulation pumps status screen	17
4.2.12	Sensors status screen	18
4.3	General menu.....	18
4.4	User menu	18
4.5	Maintenance menu	19
4.6	Installation menu.....	19
4.7	RTC menu	21
4.8	Alarms menu.....	21
4.9	Project and firmware versions.....	21
5	Parameter list	22
5.1	List of configuration parameters.....	23
5.1.1	AI parameters I/O table.....	42
5.1.2	DI parameters I/O table	43
5.1.3	DO parameters I/O table	44
5.1.4	AO parameters I/O table	44
6	Regulations	45
6.1	Machine status	45
6.2	Alarm OFF status	46
6.3	Unit type.....	46
6.4	Electric connections.....	47
6.4.1	Machine electric connections with double flow	47
6.5	Electric connections.....	49
6.5.1	Machine electric connections with single flow.....	49
6.6	Operating mode control	51
6.7	Setting the RTC	52

6.8	Plant set-up	52
6.8.1	Set-up of the heat recovery device	52
6.8.2	Set-up of the fans.....	52
6.8.3	Set up of Coil 1 type configuration	53
6.8.4	Set up of Coil 2 type configuration	54
6.9	Table of types of configurable machines.....	56
6.10	Fans.....	68
6.10.1	Continuous control.....	68
6.10.2	Continuous/On Off control	68
6.10.3	Control On/Off.....	68
6.10.4	Modulating regulation.....	69
6.10.5	Modulating control with steps to enable.....	70
6.10.6	Static Pressure control	71
6.10.7	Minimum/Maximum discharge temperature.....	72
6.10.8	"Intake cycles"	72
6.10.9	Fan status.....	73
6.10.10	Fan alarm inputs.....	73
6.10.11	Environment temperature robe in error mode	73
6.11	Main controls.....	74
6.12	Cooling and heating controls	75
6.12.1	Floating set point floating from flow	75
6.12.2	Modulating valve control.....	76
6.13	Post-heating.....	77
6.13.1	Post-heating coil for hot water.....	77
6.13.2	Electrical post heating coil.....	77
6.13.3	Post-heating resistors modulating	78
6.13.4	Resistance in summer	78
6.13.5	Status of post-heating heating elements.....	78
6.14	Dehumidification.....	79
6.14.1	Dehumidification control	79
6.14.2	Limit regulation of dehumidification	80
6.14.3	Winter dehumidification.....	81
6.15	Humidification	82
6.15.1	Enabling humidifier (flow temperature operation)	82
6.15.2	Humidifier On/Off	82
6.15.3	Step of modulating humidifier with On / Off	83
6.15.4	Maximum humidification control	83
6.15.5	Maximum humidity protection	84
6.15.6	Humidifier status	84
6.16	Dampers.....	84
6.16.1	Damper modulating regulation	84
6.16.2	Control in fixed opening.....	84
6.16.3	Enabling Free-Cooling / Free-Heating in temperature.....	85
6.16.4	Free-Cooling and Free-Heating Control	85
6.16.5	Air quality control	86
6.16.6	Damper command	86
6.16.7	Damper status	87
6.17	Heat recovery devices	87
6.17.1	Heat recovery devices at cross flow.....	88

- 6.17.2 Heat recovery devices with double coil89
- 6.17.3 Rotating heat recovery device 89
- 6.17.4 Recovery device status..... 90
- 6.18 Heating/cooling pumps 90
 - 6.18.1 Continuous control..... 90
 - 6.18.2 Control On/Off..... 90
 - 6.18.3 Pump status..... 91
 - 6.18.4 Pump alarm inputs..... 91
- 6.19 Unit with single heating-cooling coil (seasonal) 92
 - 6.19.1 Right coil steps status 92
 - 6.19.2 Primary control..... 92
- 6.20 Management (various)..... 93
 - 6.20.1 Single or distinct set point 93
 - 6.20.2 Compensation for set point 93
 - 6.20.3 Variation set point from supervisor 94
 - 6.20.4 Manual fan operation 94
- 6.21 Time schedule 94
- 6.22 Miscellaneous management..... 94
 - 6.22.1 Last date of maintenance..... 94
 - 6.22.2 Restore default parameters..... 94
- 7 Diagnostics..... 95
 - 7.1 Manual and automatic alarms 95
 - 7.1.1 Manual-reset alarms 95
 - 7.1.2 Automatic-reset alarms 95
 - 7.2 Table of Alarms..... 96
 - 7.2.1 Air flow switch alarm..... 97
 - 7.2.2 Anti-freeze alarm..... 97
 - 7.3 Alarm relay 97
 - 7.4 Alarms log..... 98
- 8 Ethernet services configuration 99
 - 8.1 Web Server 99
 - 8.1.1 WEB interface 99
 - 8.1.2 Password for the parameters modification via WEB 99
 - 8.2 MQTT 100
 - 8.3 ModBus TCP/IP 100
- 9 List of Modbus® variables 101
 - 9.1 c-pro 3 NODE kilo AHU 101

1 GENERALITIES

1.1 Description

c-pro 3 NODE kilo AHU is a controller for the management of single or double flow (with cross-flows or rotative recovery heat exchanger) air handling units with seasonal (with 1 coil, heating/cooling) and annual (with 2 coils, cooling/reversible and heating/heating support/post-heating) operation; the coils can be electric or by water.

They are available in blind version with a possible remote user interface (**Vroom**); the interface incorporates a temperature and humidity sensor (which survey can be transmitted via BUS).

The controller is able to manage the return fan and the supply fan independently (up to 3 speeds or modulating); it is also able to manage the outdoor damper, the bypass damper and the mixing chamber damper.

It has the humidifier management (both "on-off" and modulating), the ventilation modulation according to the supply static pressure and according to the room air quality.

The variety of available communication ports (RS-485, CAN, USB and Ethernet) and supported communication protocols make easier the integration of the device in systems.

Installation is on DIN rail, into a control panel.

Purchase codes

Controller (**c-pro 3 NODE kilo AHU**): **EPK4BHX1AH**

Remote user interface (**Vroom**): **EPV4RBR**

2 Dimensions

2.1 Dimensions controller

8 DIN modules; dimensions are in mm (in).

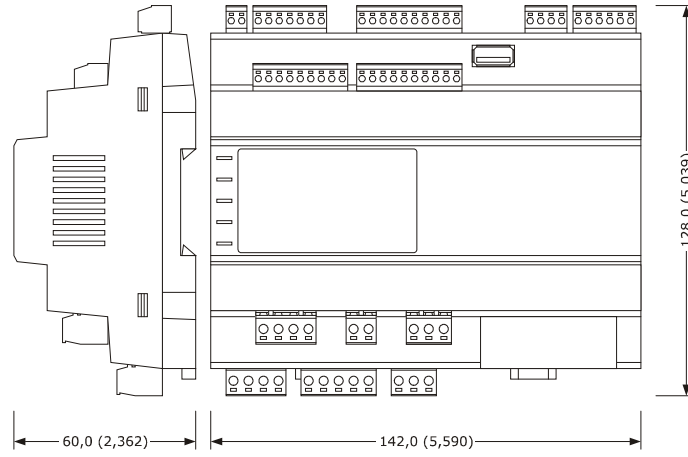

2.2 Dimensions remote user interface

Dimensions are in mm (in).

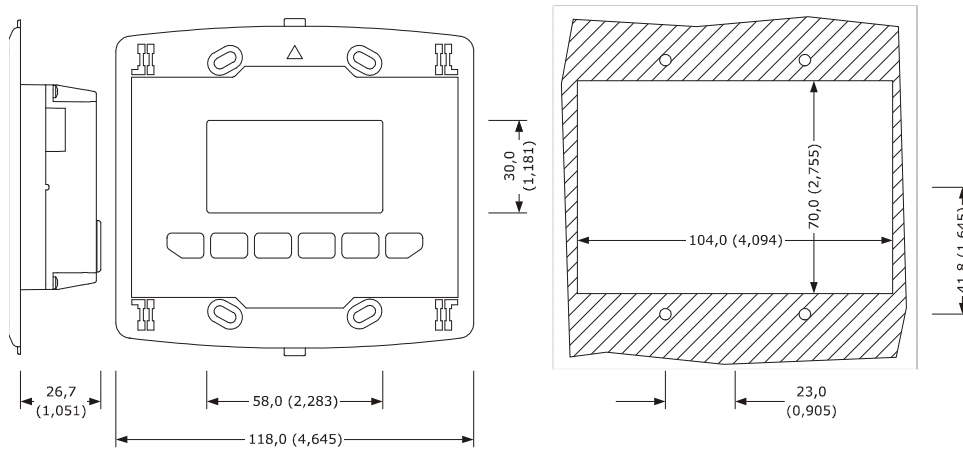

2.3 Installation remote user interface

By panel.

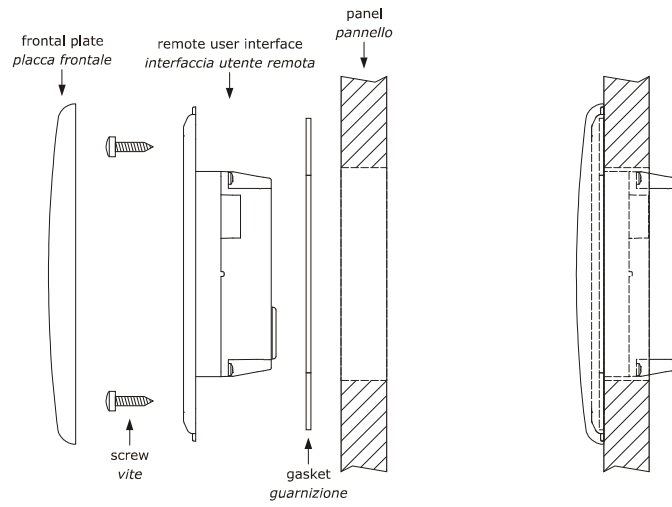

By wall (in flush box belonging to the "506e" series by BTicino).

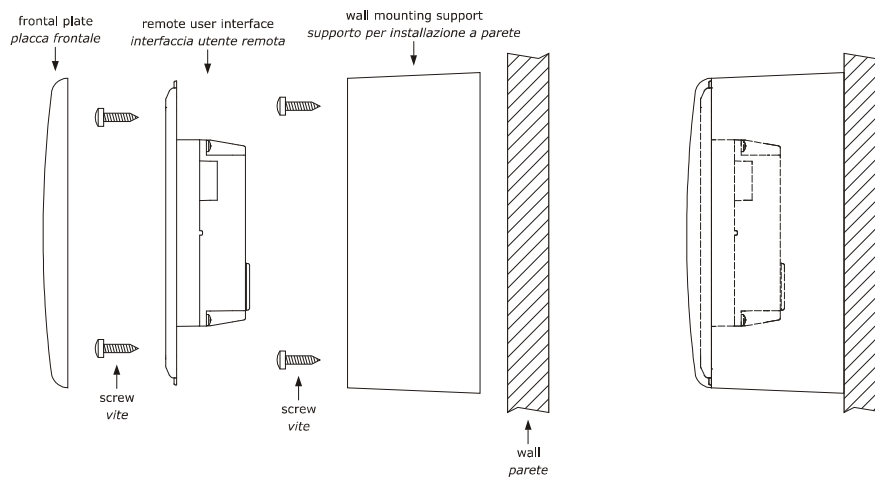

By wall (in CPVW00 wall mounting support).

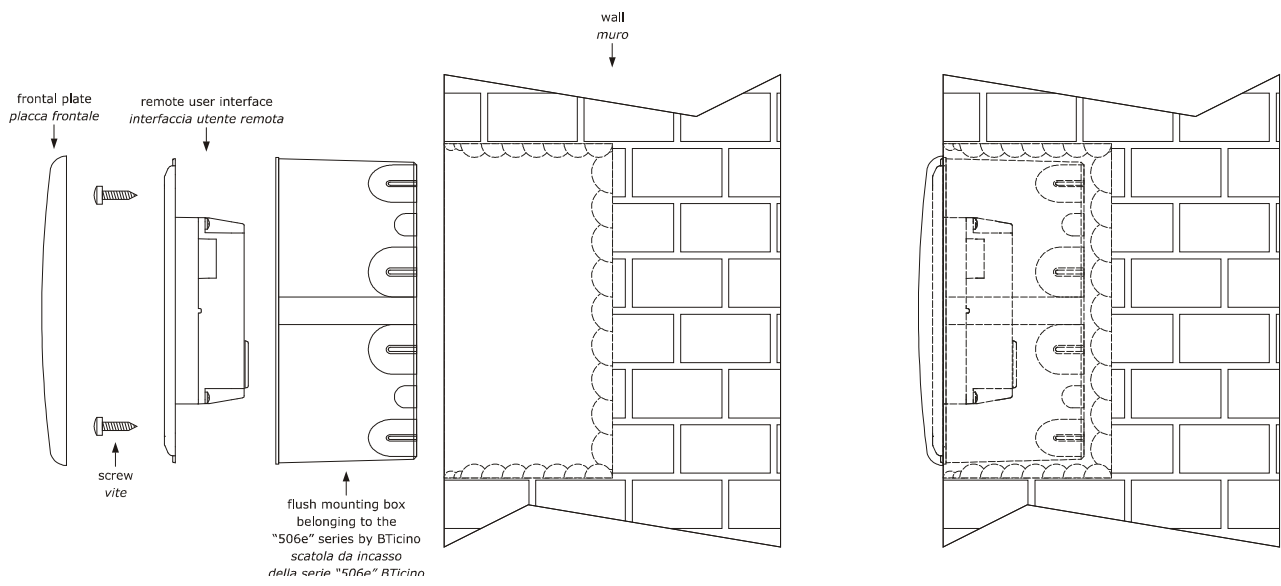

3 User interface

For the application there is an only interface: the remote user interface LCD **Vroom**.

The interface **Vroom** has 6 page-navigation and value-editing keys.



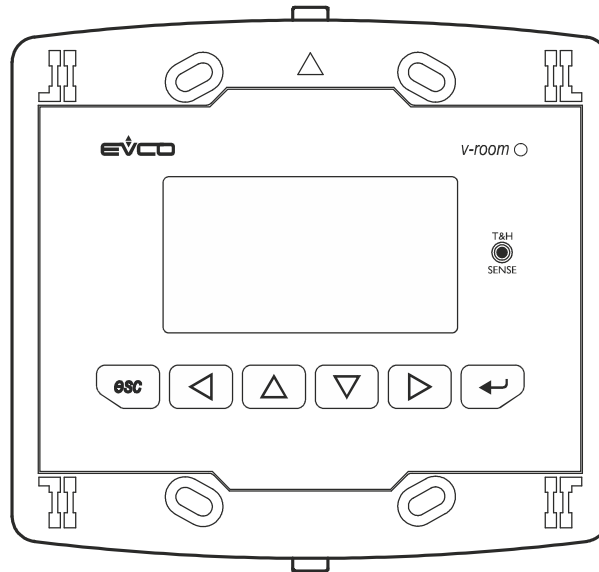

A description of the keys is available; look at the following paragraphs.

3.1 Remote user interface **Vroom**

The following drawing shows the aspect of the remote user interface **Vroom**.



The keyboard features 6 page-navigation and value-editing keys, which have the following functions:

-  and  (UP/ DOWN): during editing, it modifies parameters; otherwise, it moves the cursor
-  and  (LEFT/RIGHT): it displays the pages of the same level in succession.

In the Vroom pages, the icons are the same of the Built-In LCD Display.

-  (SET/ENTER): during editing, it confirms the value; otherwise, it sends any commands associated to the text on which the cursor is positioned.

If pressed down and held for about 2 seconds, the ENTER key allows access to the main menu

If held down during display of an alarm page, this key allows to reset the alarm When alarm pages are displayed, any key pressed allows to scroll the active alarms.

-  (Stand-BY/ESC): during editing, it cancels the value; otherwise, it requests any default page that might be associated to the actual page.

If pressed and held for 2 seconds, the ESC key allows to switch the machine on and off.

If pressed when on the main page, the key allows to access the list of active alarms.

3.2 Display that can be viewed from the *Vroom* interface

From the ages of the LCD screen of the associated user interface (Vroom), the following icons can be displayed:



Winter/Summer icon:

Winter: Winter operation active.

Summer: Summer operation active.

Alarm icon:

Invisible: No alarm.

Visible: At least 1 alarm is active.

Slow flashing: New alarm exists, but it is not displayed yet.

Scheduler icon:

Invisible: No time bands active.

T1: Time band T1 active.

T2: Time band T2 active.

T3: Time band T3 active.

H: Time band Holiday active.

Fan icon:

Invisible: Fans are off.

Visible: At least 1 fan is on.

Pump icon:

Invisible: Pumps are off.

Visible: At least 1 pump is on.

Coil icon:

Invisible: Coils are off.

Visible: At least 1 coil is on.

Damper icon:

Invisible: Damper is closed

Visible: Damper is open.

°C/°F icon: This indicates the temperature measurement unit of the selected sensor.

4 List of pages

This chapter describes the main pages and menus featured in the application. As already described earlier, the general menu is subdivided into four submenu levels: user, maintenance operator, installation operator, and configuration.

The menu structure is the following:

- General menu
- Time bands (Level 1)
- User menu (Level 1)
- Maintenance operator menu (Level 2)
- Regulations branch maintenance menu
- Manual branch maintenance menu
- Calibration branch maintenance menu
- Installation operator menu (Level 3)
- Control branch installation menu
- Fan branch installation menu
- Heating-Cooling coil branch installation menu
- Humidifier branch installation menu
- Dampers branch installation menu
- Heat recovery device branch installer menu
- Pump branch installer menu
- Protection device branch installation menu
- Modbus parameter branch installer menu
- Ethernet parameter branch installer menu
- Various parameters branch installer menu
- Default branch installation menu
- Configuration parameters branch installer menu
- Hardware AI parameters installer menu
- Hardware DI parameters installer menu
- Hardware AO parameters installer menu
- Hardware DO parameters installer menu
- RTC menu (Level 0)
- ALARMS menu (Level 0)
- Show alarms
- HISTORY menu (Level 0)
- Show alarm history
- SAVE/RESTORE menu (Level 3)

4.1 Password

A level is assigned to every menu that determines the accessibility to the various functions, via the password. Once the correct password is introduced, it is possible to access the protected functions, release the respective level and finally release the relative sub-levels. The level passwords can be modified by the same or also by upper levels, e.g. by the Manufacturer level it will be possible to modify the passwords of the lower levels. To set a password, the range of values possible goes from -999 / 9999. The valid interval for setting each individual password expires every 4 minutes, after which a new one must be set.

4.2 Main page

The status of the machine will determine a different display of the main page, i.e. it may be on or off. If the machine is switched OFF, Unit OFF is displayed, with indication of the cause for the shutdown (dedicated key, lack of consensus from digital input, supervisor, scheduler). If the machine is switched ON, the room temperature and humidity value are displayed. If the probe is faulty or disconnected, the display will show: "----". Pressing the RIGHT or LEFT keys from the main page, the information relative to the status of the circuit, of the RTC and the probes configured are also displayed. In the case of a probe error, the field of the value itself will display: "---- " or "...." if this is disabled.

4.2.1 Status pages

Once the controller is on, the ON screen will be displayed from the remote user interface **Vroom**, with the graphical icons of the statues managed by the controller.



The graphical icons shown above are briefly described, starting from the first in the bottom left, proceeding to the right.



- 1) Summer / winter / alarm
- 2) Time band T1/ T2/ T3/ Holiday / Economy(DI)
- 3) Flow fan no digital flow fan turned on / digital flow fan V1/ digital flow fan V2/ digital flow fan V3/ No analogue flow fan turned on/ Analogue flow fan V1/ Analogue flow fan V2/ analogue flow fan V3
- 4) At least 1 water coil is on.
- 5) Coil DX first step turned on / Coil DX second step turned on
- 6) At least 1 resistor on (or analogue >0)
- 7) External air DO damper open/mixing chamber damper AO>0

Pressing the ESC key from this page brings the user to the Alarm/History page.

Simultaneously pressing the LEFT and RIGHT keys for 3 seconds, from this page, you change the cooling / heating of the machine.

Following the ON screen, the individual status pages can be displayed (via LEFT/RIGHT), only and exclusively of the status in which the utilities are configured (except time bands and probes always present).

4.2.2 (TIME BANDS) screen

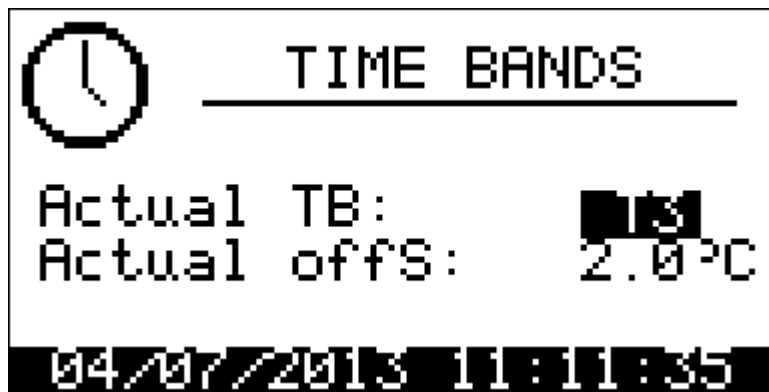

In this screen via "Actual TB" displays the current time band in use, while with "Actual offS", the active offset.

From this screen, pressing the LEFT and RIGHT keys for 3 seconds, you can reach the configuration page of the bands.

4.2.3 Fans Screen

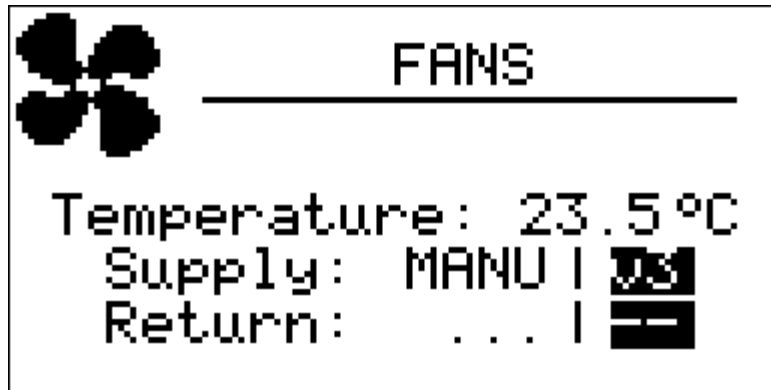

The following can be displayed in this screen status and speed of the flow and return fan

4.2.4 Regulation status of coil 1 screen

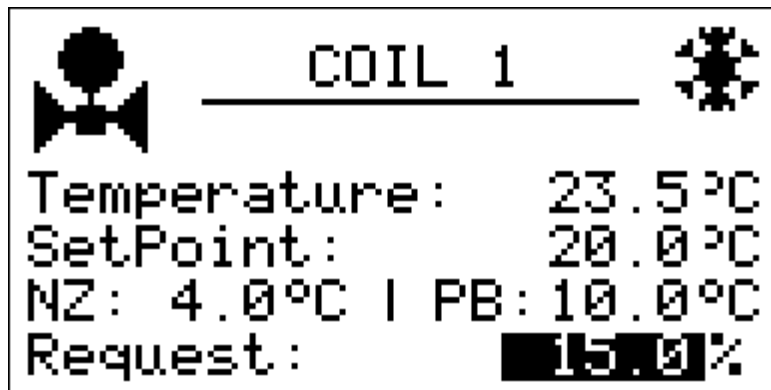

The regulation status of coil 1 is displayed

4.2.5 Regulation status of coil 2 screen

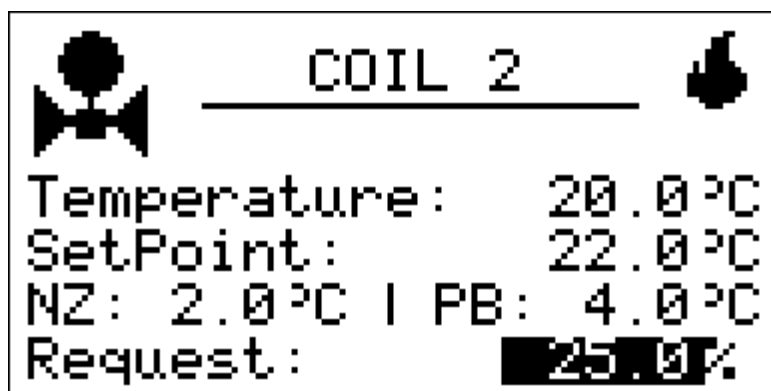

The regulation status of coil 2 is displayed

4.2.6 Direct expansion coil regulation status screen

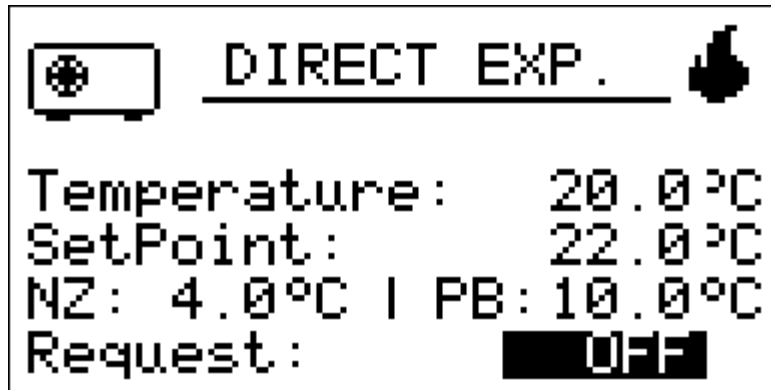

The regulation status of the direct expansion coil is displayed

4.2.7 Heating elements status screen

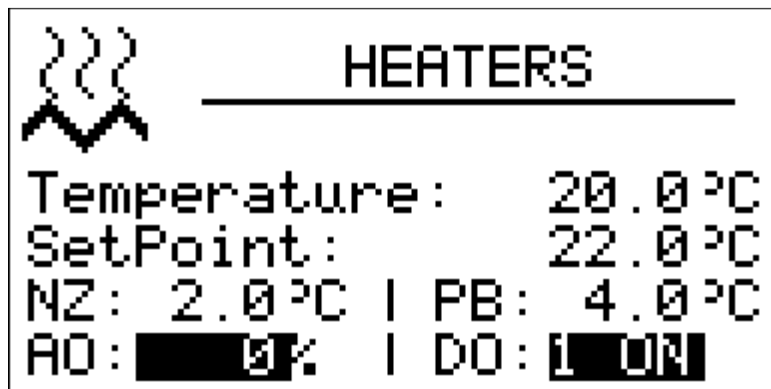

The status of the heating elements is displayed

4.2.8 Humidity regulation status screen

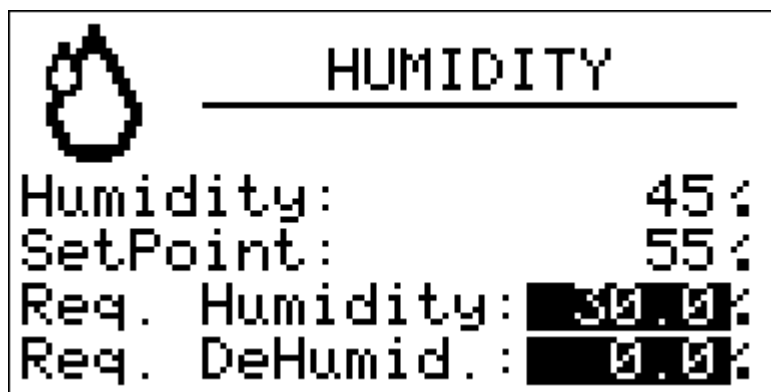

The status of the humidity regulation is displayed in this screen

4.2.9 Status screen of the damper for air circulation

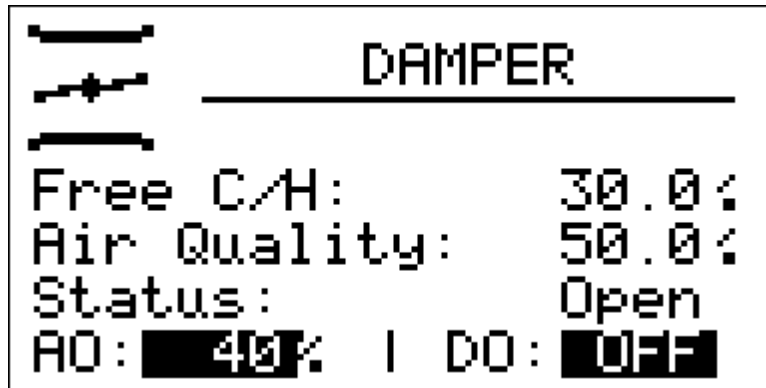

The air circulation damper status (Free-cooling/Heating) and air quality is displayed.

4.2.10 Heat recovery status screen

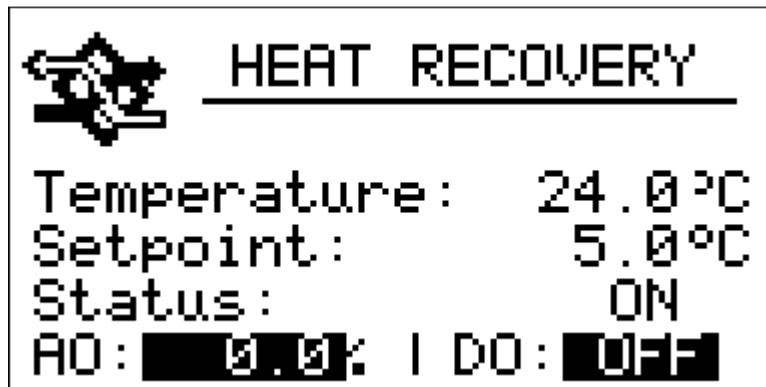

The status of the heat recovery is displayed

4.2.11 Circulation pumps status screen

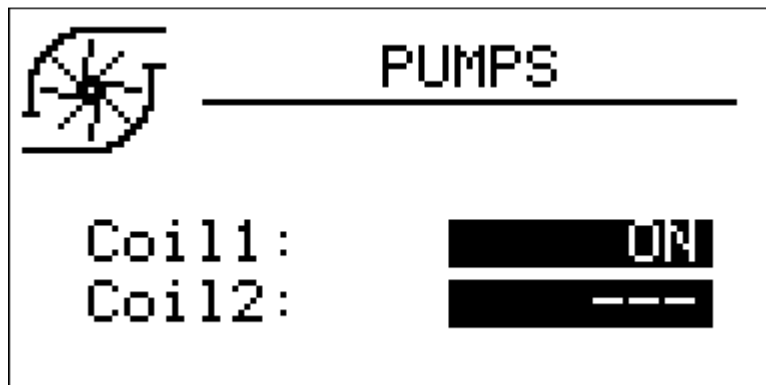

The circulation pumps status can be displayed

4.2.12 Sensors status screen

SENSORS		
Supply T.	21.0	°C
Return T.	22.5	°C
Outdoor T.	29.5	°C
Exhaust T.	23.0	°C
Return H.	45	%

The status of the sensors is displayed

4.3 General menu

The general menu has no level and represents the access point for all the other system menus.

TIME BANDS
USER
MAINTENANCE
INSTALLATION
RTC
ALARMS
HISTORY
SAVE/RESTORE

It is possible to view this menu from any point within the user interface by pressing ENTER for approximately 2 seconds. From this menu you can choose the menu you wish to view by pressing the UP and DOWN keys followed by pressing the ENTER key for confirmation.

In the upper right hand corner of the image appears a "v" which represents the focus.

This indication specifies to the user that additional information is contained therein and can be viewed by pressing the DOWN key (or UP key depending on the direction of the focus) scrolling to view the content that is not viewable in the current page. In this specific case, once the focus is on the line CONSTRUCTOR, press DOWN to proceed to the subsequent page.

4.4 User menu

The User menu is a Level 1 menu, i.e. it requires entering of the User level (or higher) password, in order to be able to display/modify the parameters contained in this branch.

The following parameters appear in this branch:

- summer/winter operating mode
- set point for winter operation or single set point
- set point for summer operation
- set point room humidity
- offset from supervisor
- offset from scheduler
- USER password

4.5 Maintenance menu

The Maintenance menu is a Level 2 menu, i.e. it requires entering of the Maintenance operator level (or higher) password, in order to be able to display/modify the parameters contained in this branch.

CONTROL
MANUAL
CALIBRATION
I/O STATUS
MAINTENANCE MENU Password

In this menu, it is possible to view the status of the various devices, inputs and outputs utilized by the application.

In the *REGULATIONS* menu, it is possible to view/enable the features relating to the operation of fans and pumps. Some examples of these are the hours of operation, the enabling of the corresponding alarms and the threshold of maximum allowable hours.

The operating value of the fan in manual mode and the steps can be set in the *MANUAL* menu.

In the *CALIBRATION* menu, it is possible to set the corrections to be applied to analogue inputs, to compensate the offsets due to cabling and sensor positioning.

In the *I/O STATUS* menu, it is possible to view directly the card's physical inputs and outputs.

4.6 Installation menu

The installation menu is a Level 3 menu, i.e. it requires entering of the installation level (or higher) password, in order to be able to display/modify the parameters contained in this branch.

CONTROL
FANS
HEATING-COOLING COILS
HUMIDIFIER
DAMPERS
HEAT RECOVERY DEVICE
PUMP
PROTECTION DEVICE
MODBUS PARAMETERS
ETHERNET PARAMETERS
VARIOUS PARAMETERS
DEFAULT
INSTALLATION MENU password
CONFIGURATION PARAMETERS
HARDWARE AI PARAMETERS
HARDWARE DI PARAMETERS
HARDWARE AO PARAMETERS
HARDWARE DO PARAMETERS

The installation Menu contains all the parameters related to the configuration of all operations (alarms, control, logic, characteristics) used for this device.

By pressing the ENTER key on the text which reads "INSTALLATION MENU" you will come to a page allowing you the option to change your password (*PSd3*)

In the CONTROL Menu you can set/view parameters for various specific controls:

- compensation control set point
- sniffing cycles for air room temperature acquisition

Within the FANS, HEATING-COOLING COILS, HUMIDIFIER, DAMPERS HEAT RECOVERY DEVICE and PUMPS menus you may set the related parameters to manage the devices:

- control parameters
- timing
- operation

The PROTECTION DEVICE menu contains all parameters connected with alarms and management of safety devices which protect the refrigerating circuit:

- activations
- reporting delays
- type of reset
- alarms signal

The MODBUS menu contains all parameters for configuration of the network.

The ETHERNET menu contains all parameters for configuration of the Ethernet network (IP, Gateway, Subnet Mask).

The VARIOUS menu contains other general parameters:

- Set maximum threshold values
- Set Modbus communication
- Enable secondary Set Point of change-over and supervisor
- Enable summer/winter modes from Digital inputs and supervisor
- Enable sensors
- Set logic for digital input/output
- Reset history
- Set unit of measurement
- Set sensor type: return temperature, flow, external, humidity, channel pressure, air quality, flow humidity, potentiometer, input logic, coil 1, coil 2, fan, damper, humidifier, heating elements, recovery device

From the DEFAULT PARAMETER menu it is possible to restore the default values of all parameters of the application and save or download from the USB pen drive.

This menu is only accessible when the device is off.

The CONFIGURATION PARAMETERS Menu allows you to set/view the parameters relating to the characteristics of the machine.

- Unit type
- Number of coils
- Enable devices

In the HARDWARE AI there are parameters relative to the use of the AI.

In the HARDWARE DI there are parameters relative to the use of the DI.

In the HARDWARE AO there are parameters relative to the use of the AO.

In the HARDWARE DO there are parameters relative to the use of the DO.

4.7 RTC menu

This menu contains the functionality of the systems Real Time Clock:

SETTING THE REAL TIME CLOCK

4.8 Alarms menu

This menu allows viewing and acknowledging of alarms.

SHOW ALARMS SHOW ALARM HISTORY

The SHOW ALARMS menu shows the active alarms. Each time the DOWN key is pressed, the next active alarm is shown. If no alarms are present, the message "NO ALARMS" is displayed.

The alarm can be acknowledged by pressing the ENTER key for 2 seconds, when the alarm condition is not active anymore.

The alarm history page will show the latest alarm. To view the preceding alarm press ENTER key. This can be repeated until the first alarm is displayed. The history is viewed in a circular manner.

By pressing the ESC key or after 60 seconds of no key activity, the main page will be displayed.

4.9 Project and firmware versions

Press simultaneously the UP+DOWN keys for about 2 seconds, then press the ENTER key on the **InFo**label.

Information on the project and controller firmware versions is displayed sequentially, namely:

Project Number <-> Project Version <-> Project Revision <->

Firmware Number <-> Firmware Version <-> Firmware Revision <->

To scroll this information, use the UP and DOWN keys. To return to the application pages, press the ESC key.

5 Parameter list

The parameters managed by the application are listed below. Each parameter is accompanied by a brief description, the range of its admissible values, units of measure, the assigned default value and the menu containing the parameter. Menus are structured on the basis of the following logic:

OR: Clock menu

UT: User menu

TB: Time Bands

MA: Maintenance menu

MA-F: Maintenance menu – operating branch

MA-M: Maintenance menu – manual branch

MA-CA: Maintenance menu – calibration branch

IS: Installation menu

IS-R: Installation menu - control branch

IS-F: Installation menu - fans branch

IS-B: Installation menu – heating-cooling coils branch

IS-U: Installation menu - humidifier branch

IS-SE: Installation menu - damper branch

IS-RH: Installation menu – heat exchanger branch

IS-P: Installation menu - pump branch

IS-S: Protection device - branch installation menu

IS-M: Installation menu - modbus branch

IS-Et: Installation menu - ethernet branch

IS-V: Installation menu - various parameter branch

IS-D: Installation menu - default branch

IS-C: Configuration parameters branch - installer menu

IS-AI: Hardware AI parameters - installer menu

IS-DI: Hardware DI parameters - installer menu

IS-AO: Hardware AO parameters - installer menu

IS-DO: Hardware DO parameters - installer menu

5.1 List of configuration parameters

Note: Once the machine parameters have been configured, and every time the configuration parameters are modified, it is advisable to shut down the machine and restart the plant, to enable the card to reconfigure itself correctly.

Code	Parameter description	Default	Min	Max	UM	Menu	Notes
	TIME BAND MENU					TB	
	Monday type band 1 0: Disable 1: T1 2: T2 3: T3	0	0	3		TB	
	Monday hour band 1	0	00:00:00	23:59:59		TB	
	Monday type band 2 0: Disable 1: T1 2: T2 3: T3	0	0	3		TB	
	Monday hour band 2	0	00:00:00	23:59:59		TB	
	Monday type band 3 0: Disable 1: T1 2: T2 3: T3	0	0	3		TB	
	Monday hour band 3	0	00:00:00	23:59:59		TB	
	Tuesday type band 1 0: Disable 1: T1 2: T2 3: T3	0	0	3		TB	
	Tuesday hour band 1	0	00:00:00	23:59:59		TB	
	Tuesday type band 2 0: Disable 1: T1 2: T2 3: T3	0	0	3		TB	
	Tuesday hour band 2	0	00:00:00	23:59:59		TB	
	Tuesday type band 3 0: Disable 1: T1 2: T2 3: T3	0	0	3		TB	

	Tuesday hour band 3	0	00:00:00	23:59:59		TB	
	Wednesday type band 1 0: Disable 1: T1 2: T2 3: T3	0	0	3		TB	
	Wednesday hour band 1	0	00:00:00	23:59:59		TB	
	Wednesday type band 2 0: Disable 1: T1 2: T2 3: T3	0	0	3		TB	
	Wednesday hour band 2	0	00:00:00	23:59:59		TB	
	Wednesday type band 3 0: Disable 1: T1 2: T2 3: T3	0	0	3		TB	
	Wednesday hour band 3	0	00:00:00	23:59:59		TB	
	Thursday type band 1 0: Disable 1: T1 2: T2 3: T3	0	0	3		TB	
	Thursday hour band 1	0	00:00:00	23:59:59		TB	
	Thursday type band 2 0: Disable 1: T1 2: T2 3: T3	0	0	3		TB	
	Thursday hour band 2	0	00:00:00	23:59:59		TB	
	Thursday type band 3 0: Disable 1: T1 2: T2 3: T3	0	0	3		TB	
	Thursday hour band 3	0	00:00:00	23:59:59		TB	

	Friday type band 1 0: Disable 1: T1 2: T2 3: T3	0	0	3		TB	
	Friday hour band 1	0	00:00:00	23:59:59		TB	
	Friday type band 2 0: Disable 1: T1 2: T2 3: T3	0	0	3		TB	
	Friday hour band 2	0	00:00:00	23:59:59		TB	
	Friday type band 3 0: Disable 1: T1 2: T2 3: T3	0	0	3		TB	
	Friday hour band 3	0	00:00:00	23:59:59		TB	
	Saturday type band 1 0: Disable 1: T1 2: T2 3: T3	0	0	3		TB	
	Saturday hour band 1	0	00:00:00	23:59:59		TB	
	Saturday type band 2 0: Disable 1: T1 2: T2 3: T3	0	0	3		TB	
	Saturday hour band 2	0	00:00:00	23:59:59		TB	
	Saturday type band 3 0: Disable 1: T1 2: T2 3: T3	0	0	3		TB	
	Saturday hour band 3	0	00:00:00	23:59:59		TB	
	Sunday type band 1 0: Disable 1: T1 2: T2 3: T3	0	0	3		TB	

	Sunday hour band 1	0	00:00:00	23:59:59		TB	
	Sunday type band 2 0: Disable 1: T1 2: T2 3: T3	0	0	3		TB	
	Sunday hour band 2	0	00:00:00	23:59:59		TB	
	Sunday type band 3 0: Disable 1: T1 2: T2 3: T3	0	0	3		TB	
	Sunday hour band 3	0	00:00:00	23:59:59		TB	
	Date start holiday	1/1/2000 00:00:00	1/1/2000 00:00:00	19/1/2006 3.14.07		TB	
	Date end holiday	1/1/2000 00:00:00	Date start holiday	19/1/2006 3.14.07		TB	
Level 1	USER MENU						
MOdE	Operating mode 0: Summer (Cooling) 1: Winter (Heating)	1	0	1	-	UT	
SEtC	Summer set point	24.0	PH03	PH04	°C		
SEtH	Set Point winter/single	20.0	PH03	PH04	°C	UT	If PH27=1 (single Set Point), the single Set Point utilized for control and SEtH.
PU01	Set Point for humidity management	55	0	100	%	UT	
OS02	Offset at control Set Point from Supervisor	0.0	-20.0	20.0	°C	UT	If PH26=1
OT01	Offset T1 active	0.0	-20.0	20.0	°C	UT	
OT02	Offset T2 active	0.0	-20.0	20.0	°C	UT	
OT03	Offset T3 active	0.0	-20.0	20.0	°C	UT	
OH01	Offset Holiday active	0.0	-20.0	20.0	°C	UT	

OE01	Economy Offset	0.0	-20.0	20.0	°C	UT	
PSd1	Password for User Level (1)	0	-999	9999	-	UT	
Level 2	MAINTENANCE OPERATOR MENU						
	CONTROL						
PM00	Limit the maximum hours of fan operation. Related alarms will sound if maximum hours are exceeded.	20000	0	100000	Hrs	MA-F	
PM01	Hours of fan operation - supply	0	0	100000	Hrs	MA-F	
PM02	Hours of fan operation - return	0	0	100000	Hrs	MA-F	
PM10	Limit the maximum hours of pump operation. Related alarms will sound if maximum hours are exceeded.	20000	0	100000	Hrs	MA-F	
PM11	Hours of cooling pump operation	0	0	100000	Hrs	MA-F	
PM12	Hours of heating pump operation	0	0	100000	Hrs	MA-F	
PM90	Last date of machine maintenance				-	MA-F	
	MANUAL						
PM22	Force the value of the fan in manual operation (step)	0	0	3		MA-M	
	CALIBRATION						
PM80	Calibration of the outdoor air temperature sensor	0.0	-10.0	10.0	°C	MA-CA	
PM81	Calibration of the room air temperature sensor	0.0	-10.0	10.0	°C	MA-CA	
PM82	Calibration of the discharge air temperature sensor	0.0	-10.0	10.0	°C	MA-CA	
PM83	Calibration of the room humidity sensor	0	-10	10	°C	MA-CA	
PM84	Calibration of the exhaust air temperature sensor	0.0	-10.0	10.0	°C	MA-CA	
PM85	Calibration of the static pressure sensor	0.0	-10.0	10.0	Bar	MA-CA	
PM86	Calibration of the air quality sensor (CO2/VOC)	0	-100	100	ppm	MA-CA	
PM87	Calibration of the discharge air humidity sensor	0	-10	10	%	MA-CA	
PM88	Calibration of the remote set-point	0.0	-10.0	10.0	°C	MA-CA	
PM89	Calibration of the remote set-point	0.0	-10.00	10.00	°C	MA-CA	
PSd2	Password Maintenance Operator Level (2)	0	-999	9999	-	MA	
Level 3	INSTALLATION OPERATOR MENU						
	CONTROL						
PC01	Enable compensation Set Point summer	NO (0)	NO (0)	YES (1)	-	IS-R	
PC02	Set Point maximum for summer compensation	28.0	SEtC	PH04	°C	IS-R	
PC03	Set Point (on external t.) at start compensation	26.0	PH03	PH04	°C	IS-R	
PC04	Differential for the summer compensation of Set Point	4.0	0.0	20.0	°C	IS-R	

PC05	Enable cycles for air quality sensors for ambient temperature (when probe is restarting)	NO (0)	NO (0)	YES (1)	-	IS-R	
PC06	Wait time prior to fan activation for air quality sensors	6	1	99	Min	IS-R	
PC07	Fan activation time for air quality sensors	2	1	30	Min	IS-R	
PC08	Activate both fans for air quality sensors 0 : NO – Only activate pickup fan 1 : YES – Activate both fans	NO (0)	NO (0)	YES (1)	-	IS-R	
PC61	Summer commutation set point	20.0	PC62	70.0	°C	IS-R	
PC62	Winter commutation set point	10.0	0.0	PC61	°C	IS-R	
PC63	Active probe for automatic changeover 0: Outdoor temp. 1: flow temp. 2: environment/return temp.	0	0	1		IS-R	
FANS							
PF01	Types of controls for fans: 0: On/Off steps regulation 1: Modulating steps regulation 2: Modulating ramp regulation 3: Static pressure ramp regulation 4: AQ steps regulation 5: Modulating AQ regulation 6: Regulation on time bands 7: Manual regulation	7	0	7	-	IS-F	
PF02	Differentials for fan control	5.0	0.0	30.0	°C	IS-F	PF01=0 PF01=1
PF03	Minimum speed for the control of fan modules	40.0	0.0	PF04	%	IS-F	
PF04	Maximum speed for the control of fan modules	100.0	PF03	100.0	%	IS-F	
PF05	Minimum time between the start-up of flow and return fans.	20	0	999	Sec	IS-F	
PF08	Differential of On/Off steps on ramp of control of fan modules	0.0	0.0	60.0	%	IS-F	PF01=2
PF09	Delay time (on and off) of On/Off steps on ramp of control of fan modules	10	0	999	Sec	IS-F	PF01=2
PF10	Flow and return fan speed in room sensor alarm	30.0	0.0	100.0	%	IS-F	
PF11	Static pressure control set point ramp	1.0	0.0	10.0	bar/min	IS-F	PF01=3
PF12	Static pressure control set point	3.0	0.0	10.0	Bar	IS-F	PF01=3
PF13	Static pressure control proportional band	0.5	0.0	5.0	Bar	IS-F	PF01=3
PF14	Static pressure control integral time	0	0	300	Sec	IS-F	PF01=3
PF15	Enable fan limitation	0 (No)	0 (No)	1 (Yes)	-	IS-F	
PF16	Min. temperature of limitation	10.0	-15.0	70.0	°C	IS-F	

PF17	Max. temperature of limitation	40.0	-15.0	70.0	°C	IS-F	
PF18	Differentials for fan limitation	5.0	0.0	30.0	°C	IS-F	
PF19	Air Quality regulation min set point	500	0	10000	ppm	IS-F	PF01=4 PF01=5
PF20	Air Quality regulation max set point	1100	0	10000	ppm	IS-F	PF01=4 PF01=5
PF21	Value of first modulating step	33.0	0.0	PF22	%	IS-F	
PF22	Value of second modulating step	66.0	PF21	PF23	%	IS-F	
PF23	Value of third modulating step	100.0	PF22	100.0	%	IS-F	
PF24	Fans speed change time	2	0	999	sec	IS-F	
PF25	Fans switch-on minimum time	60	0	999	sec	IS-F	
PF26	Enable post-ventilation	1 (Yes)	0 (No)	1 (Yes)		IS-F	
PF27	Fans time in post-ventilation	30	0	999	sec	IS-F	
PF28	Return fan percentage delta	0.0	-100.00	100.00	%	IS-F	
PF29	Return fan step delta	0	-2	2	step	IS-F	
HEATING-COOLING COILS							
Pb01	Proportional band for control of valves (cooling/heating)	10.0	0.0	20.0	°C	IS-B	
Pb02	Integral time for control of valves (cooling/heating)	0	0	999	Sec	IS-B	If Pb02=0 integral action not present
Pb03	Neutral zone temperature control	4.0	0.0	20.0	°C	IS-B	
Pb05	Maximum shifting for Set Point calculation running of return	0.0	0.0	20.0	°C	IS-B	If Pb05=0 function not enabled
Pb06	Proportional band for the Set Point calculation running of return	5.0	0.0	20.0	°C	IS-B	
Pb10	Opening of heating valves alarm sensor return	30.0	0.0	100.0	%	IS-B	
Pb11	Opening of cooling valves alarm sensor return	30.0	0.0	100.0	%	IS-B	
Pb15	Priority of cooling request 0: Cooling 1: Dehumidification 2: Highest 3: Medium	0	0	3		IS-B	
Pb20	Insertion/release time single stage of heating element for the post-heating	60	0	999	Sec	IS-B	
Pb21	Second entire neutral area for heat in the case of 2 hot coils	12.0	0.0	20.0	°C	IS-B	
Pb22	Second differential in the case of 2 hot coils	3.0	0.0	10.0	°C	IS-B	
Pb23	Neutral zone for midseason control	12.0	0.0	20.0	°C	IS-B	

Pb24	Differential for midseason control	3.0	0.0	10.0	°C	IS-B	
Pb25	Minimum value for modulating output resistances	0.00	0.00	100.00	%	IS-B	
Pb30	Enable flow limitation 0: Disabled 1: Heating 2: Cooling 3: Enabled	3	0	3		IS-B	
Pb31	Cooling limitation set point	10.0	-15.0	70.0	°C	IS-B	
Pb32	Cooling limitation differential	5.0	0.0	30.0	°C	IS-B	
Pb33	Cooling limitation minimum value	0.0	0.0	100.0	%	IS-B	
Pb34	Heating limitation set point	30.0	-15.0	70.0	°C	IS-B	
Pb35	Heating limitation differential	5.0	0.0	30.0	°C	IS-B	
Pb36	Heating limitation minimum value	0.0	0.0	100.0	%	IS-B	
	HUMIDIFIER						
PU02:	Neutral zone humidity control	6	0	100	%	IS-U	
PU03	Differential for the control of humidity	10	0	100	%	IS-U	
PU04	Integral time for the control of dehumidification (with cold coil)	0	0	999	Sec	IS-U	If PU04=0 integral action not present
PU05	Enable functional limit for the dehumidification	NO (0)	NO (0)	YES (1)	-	IS-U	
PU06	Sensor for the control of humidity: 0: Environment/return 1: Flow	0	0	1	-	IS-U	
PU10	Enable humidifier control with return temperature	YES (1)	NO (0)	YES (1)	-	IS-U	
PU11	Set Point on the return temperature to enable the humidifier	22.0	PH03	PH04	°C	IS-U	Only if PU10=1
PU12	Differential on the return temperature to enable the humidifier	3.0	0.0	20.0	°C	IS-U	Only if PU10=1
PU13	Enable maximum discharge air humidity control	YES (1)	NO (0)	YES (1)	-	IS-U	
PU14	Maximum discharge air humidity set point	80	0	95	%	IS-U	
PU15	Hysteresis maximum discharge air humidity control	20	0	40	%	IS-U	
PU16	Minimum value for modulating humidifier output	0.00	0.00	100.00	%	IS-U	
PU17	Enable winter dehumidification: 0: function is not enabled 1: function enabled	1	0	1	-	IS-U	
PU18	Set-point for the management winter dehumidification	55	0	100	%	UT	

PU19	Neutral zone management winter dehumidification	6	0	100	%	IS-U	
PU20	Differential management winter dehumidification	10	0	100	%	IS-U	
PU21	Integral time management winter dehumidification	0	0	999	Sec	IS-U	If PU04 = 0 integral action is not present
PU22	Set-point maximum aperture winter Dehumidification	50.00	0.00	100.00	%	IS-U	
PU23	Maximum differential opening winter Dehumidification	20.00	0.00	100.00	%	IS-U	
PU24	Type winter dehumidification: 0: only dehumidifies winter 1: only adjustment 2: larger of the two 3: average of the two	0	0	3	-	IS-U	
DAMPERS							
PS01	Type of Free-Cooling / Free-Heating 0: Disabled 1: Free-Cooling / Free-Heating in temperature	1	0	1	-	IS-SE	
PS03	Damper command type 0: Only for Free-Cooling/Free-Heating 1: Only for controlling air quality 2: Priority to the greater of the two requests 3: Average of the two requests 4: Fixed opening	0	0	4	-	IS-SE	
PS05	Minimum opening for the dampers	20.0	0.0	PS06	%	IS-SE	
PS06	Maximum opening for the dampers	100.0	PS05	100.0	%	IS-SE	
PS07	Pre-start time	45	0	65535	Sec	IS-SE	
PS08	Switch-off delay	15	0	999	Sec	IS-SE	
PS09	End run time	30	0	999	Sec	IS-SE	
PS10	Fixed value for opening dampers	50.0	0.0	100.0	%	IS-SE	
PS12	Differential enabling free-cooling and free-heating in temperature	2.0	0.0	20.0	°C	IS-SE	
PS13	Differential Set Point enabling free-cooling and free-heating in temperature	4.0	0.0	20.0	°C	IS-SE	
PS15	Minimum and maximum opening of dampers 0: Disabled 1: Only inside band 2: Always	2	0	2	-	IS-SE	
PS20:	Set Point – Air Quality Control	600	0	10000	ppm	IS-SE	

PS21:	Differential – Air Quality Control	100	0	2000	ppm	IS-SE	
	HEAT RECOVERY DEVICE						
Pr01	Differential Set Point for control of heat exchanger	5.0	0.0	20.0	°C	IS-RH	
Pr02	Differential of control of heat exchanger	3.0	0.0	20.0	°C	IS-RH	
Pr03	Minimum Set Point expulsion temperature	1.0	PH03	PH04	°C	IS-RH	
Pr04	Differential minimum expulsion temperature	4.0	0.0	20.0	°C	IS-RH	
Pr05	By pass cycle time of heat exchangers at cross flow for melting	5	1	99	Min	IS-RH	
Pr07	Minimum velocity of rotating heat exchanger velocity	0.0	0.0	Pr08	%	IS-RH	
Pr08	Maximum velocity of rotating heat exchanger velocity	100.0	Pr07	100.0	%	IS-RH	
	PUMP <i>Menu accessible only if PG10=1 or PG11=1</i>						
PP01	Types of pump control 0: Continuous adjustment 1: Control On/Off	0	0	1	-	IS-P	
PP02	Set Point on the control ramp for pump start-up	5.0	PP03	90.0	%	IS-P	Only if PP01=1
PP03	Set Point on the control ramp for pump shutdown	2.0	1.0	PP02	%	IS-P	
PP04	Wait time for pump shutdown (only with PP01=1)	10	1	99	Min	IS-P	OFF – Unit immediately shuts down pump
	PROTECTION DEVICE						
PA01	Enable alarms during hours of fan operation	YES (1)	NO (0)	YES (1)	-	IS-S	
PA02	Enable alarms during hours of pump operation	NO (0)	NO (0)	YES (1)	-	IS-S	
PA03	Signal alarms during hours of operation on alarm relay	YES (1)	NO (0)	YES (1)	-	IS-S	
PA04	Sensor alarm delay	10	0	240	Sec	IS-S	
PA05	Signal alarm sensor on alarm relay	YES (1)	NO (0)	YES (1)	-	IS-S	
PA09	Signal fan alarms on alarm relay	YES (1)	NO (0)	YES (1)	-	IS-S	
PA16	Signal alarms thermal pumps on alarm relay	YES (1)	NO (0)	YES (1)	-	IS-S	
PA20	Type of pressure switch alarm re-arm (heat recovery device) 0: Auto - Automatic 1: Manu - Manual	Manu (1)	Auto (0)	Manu (1)	-	IS-S	

PA21	Pressure switch alarm delay (heat recovery device)	30	0	999	Sec	IS-S	
PA22	Type of general alarm reset 0: Auto - Automatic 1: Manu - Manual	Manu (1)	Auto (0)	Manu (1)	-	IS-S	
PA23	General alarm delay	30	0	999	Sec	IS-S	
PA24	Type of alarm re-arm pressure switch air filter 0: Auto - Automatic 1: Manu - Manual	Manu (1)	Auto (0)	Manu (1)	-	IS-S	
PA25	Pressure switch air filter alarm delay	2	0	999	Sec	IS-S	
PA26	Signal alarms pressure switch air filter alarm relay	YES (1)	NO (0)	YES (1)	-	IS-S	
PA28	Reset airflow meter alarm delay	30	0	999	Sec	IS-S	
PA29	Airflow meter alarm delay	5	0	999	Sec	IS-S	
PA30	Signal alarm air flow meter on alarm relay	YES (1)	NO (0)	YES (1)	-	IS-S	
PA31	Type of humidifier/hygrostat alarm reset 0: Auto - Automatic 1: Manu - Manual	Auto (0)	Auto (0)	Manu (1)	-	IS-S	
PA32	Humidifier/hygrostat alarm delay	2	0	999	Sec	IS-S	
PA33	Signal alarms humidifier/ hygrostat on alarm relay	YES (1)	NO (0)	YES (1)	-	IS-S	
PA34	Resistor circuit breaker alarm reset type 0: Auto - Automatic 1: Manu - Manual	Auto (0)	Auto (0)	Manu (1)	-	IS-S	
PA35	Heating element circuit breaker alarm delay	2	0	999	Sec	IS-S	
PA36	Anti-freeze alarm delay	5	0	999	Sec	IS-S	
PA37	Signal alarm anti-freeze on alarm delay	YES (1)	NO (0)	YES (1)	-	IS-S	
PA40	Enable RTC alarm	YES (1)	NO (0)	YES (1)		IS-S	
PA41	Type of RTC alarm restoration 0: Auto - Automatic 1: Manu - Manual	Manu (1)	Auto (0)	Manu (1)	-	IS-S	
PA42	Signal RTC alarms on alarm relay	YES (1)	NO (0)	YES (1)	-	IS-S	
PA45	Signal alarms fire/smoke on alarm relay	YES (1)	NO (0)	YES (1)	-	IS-S	
	MODBUS PARAMETERS						
PH11	Board Modbus address	1	1	247	-	IS-M	
PH12	Baud Rate of communication for the card (0=1200, 1=2400, 2=4800, 3=9600, 4=19200)	3	0	4	-	IS-M	

PH13	ModBus parity (0=none, 1=Odd, 2=Even)	2	0	2	-	IS-M	
PH14	Stop Bit ModBus (0=1bit, 1=2bit)	0	0	1	-	IS-M	
VARIOUS PARAMETERS							
PE01	Board's IP address	192.16 8.0.2	0.0.0.0	255.25 5.255.2 55	-	IS-Et	
PE02	SubNet mask for TCP/IP connection	255.25 5.255.0	0.0.0.0	255.25 5.255.2 55	-	IS-Et	
PE03	Gateway for TCP/IP connection	192.16 8.0.1	0.0.0.0	255.25 5.255.2 55	-	IS-Et	
VARIOUS PARAMETERS							
PH01	Minimum value threshold for the pressure sensor	0	0.0	PH02	Bar	IS-V	
PH02	Maximum value threshold for the pressure sensor	30.0	PH01	100.0	Bar	IS-V	
PH03	Minimum temperature value for the Set Point	-5.0	-15.0	PH04	°C	IS-V	
PH04	Maximum temperature value for the Set Point	40.0	PH03	70.0	°C	IS-V	
PH05	Enable machine start-up/shut-down by pressing the ESC/Stand-By key	YES (1)	NO (0)	YES (1)	-	IS-V	
PH06	Enable the change in summer/winter operating modes utilizing the keyboard (ModE parameter)	YES (1)	NO (0)	YES (1)	-	IS-V	
PH07	Enable the change in summer/winter operating modes from DI	NO (0)	NO (0)	YES (1)		IS-V	
PH08	Enable the change in summer/winter operating modes: automatic change-over	NO (0)	NO (0)	YES (1)	-	IS-V	
PH09	Enable machine start-up/shut-down as supervisor	NO (0)	NO (0)	YES (1)		IS-V	
PH10	Enable the change in summer/winter operating modes as supervisor	NO (0)	NO (0)	YES (1)		IS-V	
PH18	Cancel alarm history	NO (0)	NO (0)	YES (1)	-	IS-V	Set YES (1) and wait for value NO (0)
PH19	Enable machine start-up/shut-down by schedule	NO (0)	NO (0)	YES (1)		IS-V	
PH20	Enable scheduler	NO (0)	NO (0)	YES (1)	-	IS-V	
PH21	Enable holiday function	NO (0)	NO (0)	YES (1)	-	IS-V	

PH26	Enable variation Set Point as Supervisor	NO (0)	NO (0)	YES (1)	-	IS-V	
PH27	Enable distinct/single Set Point for heating/cooling: 0: Distinct set point 1: Unique set point	0	0	1	-	IS-V	If PH27=1 (single Set Point), the single Set Point utilized for control and SEtH.
PH32	Unit of measurement of temperature: 0: °Celsius 1: °Fahrenheit	0 (°C)	0 (°C)	1 (°F)	-	IS-V	
PH33	Unit of measurement of pressure: 0: Bar 1: psi	0 (Bar)	0 (Bar)	1 (psi)	-	IS-V	
PH34	Language: 0: English 1: Italian	0 (Bar)	0 (Bar)	1 (psi)	-	IS-V	
PH37	PPM transducer minimum value CO2/VOC	0	0	10000	ppm	IS-V	
PH38	PPM transducer maximum value CO2/VOC	2000	0	10000	ppm	IS-V	
PH40	Type of return temperature sensor 0: PTC 1: NTC 2: PT1000 3: NTC 10K-2 4: NTC 10K-3	1	0	4	-	IS-V	
PH41	Type of flow temperature sensor 0: PTC 1: NTC 2: PT1000 3: NTC 10K-2 4: NTC 10K-3	1	0	4	-	IS-V	
PH42	Type of external temperature sensor 0: PTC 1: NTC 2: PT1000 3: NTC 10K-2 4: NTC 10K-3	1	0	4	-	IS-V	
PH43	Type of return/environment humidity sensor 0: 0-20mA 1: 4-20mA 2: 0-5V 3: 0-10V	3	0	3	-	IS-V	

PH44	Type of expelled air temperature sensor 0: PTC 1: NTC 2: PT1000 3: NTC 10K-2 4: NTC 10K-3	1	0	4	-	IS-V	
PH45	Type of channel pressure sensor 0: 0-20mA 1: 4-20mA 2: 0-5V 3: 0-10V	3	0	3	-	IS-V	
PH46	Type of air quality sensor 0: 0-20mA 1: 4-20mA 2: 0-5V 3: 0-10V	3	0	3	-	IS-V	
PH47	Type of flow humidity sensor 0: 0-20mA 1: 4-20mA 2: 0-5V 3: 0-10V	3	0	3	-	IS-V	
PH48	Type of remote set point potentiometer sensor 0: 0-20mA 1: 4-20mA 2: 0-5V 3: 0-10V	3	0	3	-	IS-V	
PH49	Type of damper potentiometer sensor 0: 0-20mA 1: 4-20mA 2: 0-5V 3: 0-10V	3	0	3	-	IS-V	
PH50:	Logic for Digital inputs for remote On/Off:	NO (0)	NO (0)	NC (1)	-	IS-V	
PH51	Logic for Digital inputs used for fans alarm	NO (0)	NO (0)	NC (1)	-	IS-V	
PH52	Logic for Digital inputs used for the alarm air flow	NO (0)	NO (0)	NC (1)	-	IS-V	
PH53	Logic for Digital inputs used for alarm fire-smoke	NC (1)	NO (0)	NC (1)	-	IS-V	
PH54	Logic for Digital inputs used for coil 1 pump alarm	NO (0)	NO (0)	NC (1)	-	IS-V	

PH55	Logic for Digital inputs used for coil 2 pump alarm	NO (0)	NO (0)	NC (1)	-	IS-V	
PH56	Logic for Digital inputs used for humidifier alarm	NO (0)	NO (0)	NC (1)	-	IS-V	
PH57	Logic for Digital inputs used for antifreeze alarm	NO (0)	NO (0)	NC (1)	-	IS-V	
PH58	Logic for Digital inputs used for air filter alarm	NO (0)	NO (0)	NC (1)	-	IS-V	
PH59	Logic for Digital inputs used for heat exchanger alarm	NO (0)	NO (0)	NC (1)	-	IS-V	
PH60	Electric coil alarm digital input logic	NO (0)	NO (0)	NC (1)	-	IS-V	
PH61	Economy digital input logic	NO (0)	NO (0)	NC (1)	-	IS-V	
PH62	Summer/winter digital input logic	NO (0)	NO (0)	NC (1)	-	IS-V	
PH63	General alarm digital input logic	NO (0)	NO (0)	NC (1)	-	IS-V	
PH64	Cooling unit defrosting digital input logic	NO (0)	NO (0)	NC (1)	-	IS-V	
PH65	External air damper end run digital input logic	NO (0)	NO (0)	NC (1)	-	IS-V	
PH70	Steps relay logic/fans enabling	NO (0)	NO (0)	NC (1)	-	IS-V	
PH71	Eternal air damper relay logic	NO (0)	NO (0)	NC (1)	-	IS-V	
PH72	Recovery device by pass relay logic	NO (0)	NO (0)	NC (1)	-	IS-V	
PH73	Humidifier relay logic	NO (0)	NO (0)	NC (1)	-	IS-V	
PH74	Heating elements relay logic	NO (0)	NO (0)	NC (1)	-	IS-V	
PH75	Condenser On-Off relay logic	NO (0)	NO (0)	NC (1)	-	IS-V	
PH76	RH coil steps relay logic	NO (0)	NO (0)	NC (1)	-	IS-V	
PH77	Logic for alarm relay	NO (0)	NO (0)	NC (1)	-	IS-V	
PH78	Summer/winter relay logic	NO (0)	NO (0)	NC (1)	-	IS-V	
PH79	Pumps relay logic	NO (0)	NO (0)	NC (1)	-	IS-V	

PH80	Type of coil 1 AO sensor 1=0-20mA 2=4-20mA 3=0-10V	3	1	3	-	IS-V	
PH81	Type of coil 2 AO sensor 1=0-20mA 2=4-20mA 3=0-10V	3	1	3	-	IS-V	
PH82	Type of flow fan AO sensor 1=0-20mA 2=4-20mA 3=0-10V	3	1	3	-	IS-V	
PH83	Type of return fan AO sensor 1=0-20mA 2=4-20mA 3=0-10V	3	1	3	-	IS-V	
PH84	Type of mixing chamber damper AO sensor 1=0-20mA 2=4-20mA 3=0-10V	3	1	3	-	IS-V	
PH85	Type of humidifier AO sensor 1=0-20mA 2=4-20mA 3=0-10V	3	1	3	-	IS-V	
PH86	Type of heating element AO sensor 1=0-20mA 2=4-20mA 3=0-10V	3	1	3	-	IS-V	
PH87	Type of rotary recovery device AO sensor 1=0-20mA 2=4-20mA 3=0-10V	3	1	3	-	IS-V	
PH90	Minimum value for the set point modification potentiometer	-5.0	-10.0	PH91	°C	IS-V	
PH91	Maximum value for the set point modification potentiometer	5.0	PH90	10.0	°C	IS-V	
PH92	Meaning of the icon summer/winter 0: Sun/Summer - Snow/Winter 1: Sun/Winter - Snow/Summer	0	0	1		IS-V	
	DEFAULT						
PH15	Restoring the manufacturers' default parameters	NO (0)	NO (0)	YES (1)	-	IS-D	Wait for the value NO(0) upon completion of restore

PSd3	Password Installation Operator Level (3)	0	-999	9999	-	IS	
CONFIGURATION PARAMETERS							
PG00	Unit type * <i>*see unit table</i>	0	0	46	-	IS-C	
PG01	Enable recovery device	NO (0)	NO (0)	YES (1)	-	IS-C	
PG02	Ventilation steps	0	0	3	-	IS-C	
PG03	Coil 1 type 0: Disabled 1: Water 2: Heating elements 3: Direct expansion	0	0	3	-	IS-C	
PG04	Coil 1 mode 0: Disabled 1: Cooling 2: Heating 3: Cooling/Heating	0	0	3	-	IS-C	
PG05	Coil 2 type 0: Disabled 1: Water 2: Heating elements	0	0	2	-	IS-C	
PG06	Type of resistors 0: Disabled 1: 1 step DO 2: 2 step DO 3: modulating on AO	0	0	3	-	IS-C	
PG07	Direct expansion steps 0: Disabled 1: 1 step DO 2: 2 step DO	0	0	2	-	IS-C	
PG12	Enable dehumidification	NO (0)	NO (0)	YES (1)	-	IS-C	
PG13	Manage heating heat exchanger 0: Disabled 1: at cross flow 2: with two coils 3: rotating On/Off (DO) 4: rotating Modulating (AO)	0	0	4	-	IS-C	
PG14	Positioning sensor of control: 0: environment probe 1: probe in restart channel	Amb. (0)	Amb. (0)	Rest. (1)	-	IS-C	
HARDWARE AI PARAMETERS							

HA00	Use of temperature and environment humidity probes 0: none 1: VRoomT 2: VRoomTH	2	0	2	-	IS-AI	
HA01	Assignment AI1 (see table par. 4.1.1)	0	0	28	-	IS-AI	
HA02	Assignment AI2 (see table par. 4.1.1)	0	0	28	-	IS-AI	
HA03	Assignment AI3 (see table par. 4.1.1)	0	0	28	-	IS-AI	
HA04	Assignment AI4 (see table par. 4.1.1)	0	0	22	-	IS-AI	
HA05	Assignment AI5 (see table par. 4.1.1)	0	0	22	-	IS-AI	
HA06	Assignment AI6 (see table par. 4.1.1)	0	0	22	-	IS-AI	
HA07	Assignment AI7 (see table par. 4.1.1)	0	0	28	-	IS-AI	
HA08	Assignment AI8 (see table par. 4.1.1)	0	0	28	-	IS-AI	
HA09	Assignment AI9 (see table par. 4.1.1)	0	0	28	-	IS-AI	
HA10	Assignment AI10 (see table par. 4.1.1)	0	0	28	-	IS-AI	
HARDWARE DI PARAMETERS							
HB01	Assignment DI1 (see table par. 4.1.2)	0	0	18	-	IS-DI	
HB02	Assignment DI2 (see table par. 4.1.2)	0	0	18	-	IS-DI	
HB03	Assignment DI3 (see table par. 4.1.2)	0	0	18	-	IS-DI	
HB04	Assignment DI4 (see table par. 4.1.2)	0	0	18	-	IS-DI	
HB05	Assignment DI5 (see table par. 4.1.2)	0	0	18	-	IS-DI	
HB06	Assignment DI6 (see table par. 4.1.2)	0	0	18	-	IS-DI	
HB07	Assignment DI7 (see table par. 4.1.2)	0	0	18	-	IS-DI	
HB08	Assignment DI8 (see table par. 4.1.2)	0	0	18	-	IS-DI	
HB09	Assignment DI9 (see table par. 4.1.2)	0	0	18	-	IS-DI	
HB10	Assignment DI10 (see table par. 4.1.2)	0	0	18	-	IS-DI	
HB11	Assignment DI11 (see table par. 4.1.2)	0	0	18	-	IS-DI	

HB12	Assignment DI12 (see table par. 4.1.2)	0	0	18	-	IS-DI	
HB13	Assignment DI13 (see table par. 4.1.2)	0	0	18	-	IS-DI	
HARDWARE AO PARAMETERS							
HC01	Assignment AO1 (see table par. 4.1.4)	0	0	8	-	IS-AO	
HC02	Assignment AO2 (see table par. 4.1.4)	0	0	8	-	IS-AO	
HC03	Assignment AO3 (see table par. 4.1.4)	0	0	8	-	IS-AO	
HC04	Assignment AO4 (see table par. 4.1.4)	0	0	8	-	IS-AO	
HC05	Assignment AO5 (see table par. 4.1.4)	0	0	8	-	IS-AO	
HC06	Assignment AO6 (see table par. 4.1.4)	0	0	8	-	IS-AO	
HCF1	Flow fan PWM frequency	10	10	2000	Hz	IS-AO	
HCF2	Return fan PWM frequency	10	10	2000	Hz	IS-AO	
HARDWARE DO PARAMETERS							
HD01	Assignment DO1 (see table par. 4.1.3)	0	0	18	-	IS-DO	
HD02	Assignment DO2 (see table par. 4.1.3)	0	0	18	-	IS-DO	
HD03	Assignment DO3 (see table par. 4.1.3)	0	0	18	-	IS-DO	
HD04	Assignment DO4 (see table par. 4.1.3)	0	0	18	-	IS-DO	
HD05	Assignment DO5 (see table par. 4.1.3)	0	0	18	-	IS-DO	
HD06	Assignment DO6 (see table par. 4.1.3)	0	0	18	-	IS-DO	
HD07	Assignment DO7 (see table par. 4.1.3)	0	0	18	-	IS-DO	
HD08	Assignment DO8 (see table par. 4.1.3)	0	0	18	-	IS-DO	
HD09	Assignment DO9 (see table par. 4.1.3)	0	0	18	-	IS-DO	
HD10	Assignment D10 (see table par. 4.1.3)	0	0	18	-	IS-DO	
HD11	Assignment D11 (see table par. 4.1.3)	0	0	18	-	IS-DO	

Note: Once the machine parameters have been configured, and every time the configuration parameters are modified, it is advisable to shut down the machine and restart the plant, to enable the card to reconfigure itself correctly.

5.1.1 AI parameters I/O table

AI1-2-3-7-8-9		
Code	Description	Notes
0	Disabled	
1	Flow Temperature	Always
2	Return temperature/environment	
3	External temperature	
4	Expelled air temperature	
5	Humidity in return mode/environment	
6	Channel pressure	
7	IAQ	
8	Humidity in flow mode	
9	Set modification potentiometer	
10	Dampers opening potentiometer	
11	Antifreeze thermostat	
12	Filter differential pressure switch	
13	remote ON-OFF	
14	Summer-Winter	
15	Economy	
16	General alarm input	
17	Chiller unit defrosting	
18	Flow fan circuit breaker	
19	Return fan circuit breaker	
20	External air dampers end run	Always
21	Humidifier alarm	
22	Electric coil circuit breaker	
23	Coil first pump circuit breaker	
24	Coil second pump circuit breaker	
25	Exchanger pressure switch (anti-freeze)	
26	Flow air flow switch	
27	Return air flow switch	
28	Fire/smoke	
AI4-5-6		
Code	Description	Notes
0	Disabled	
1	Flow Temperature	Always
2	Return temperature	
3	External temperature	
4	Expelled air temperature	
5	Antifreeze thermostat	
6	Filter differential pressure switch	
7	remote ON-OFF	
8	Summer-Winter	
9	Economy	

10	General alarm input	
11	Chiller unit defrosting	
12	Flow fan circuit breaker	
13	Return fan circuit breaker	
14	External air dampers end run	Always
15	Humidifier alarm	
16	Electric coil circuit breaker	
17	Coil first pump circuit breaker	
18	Coil second pump circuit breaker	
19	Exchanger pressure switch (anti-freeze)	
20	Flow air flow switch	
21	Return air flow switch	
22	Fire/smoke	

5.1.2 **DI parameters I/O table**

DI		
Code	Description	Notes
0	Disabled	
1	Antifreeze thermostat	
2	Filter differential pressure switch	
3	remote ON-OFF	
4	Summer-Winter	
5	Economy	
6	General alarm input	
7	Chiller unit defrosting	
8	Flow fan circuit breaker	
9	Return fan circuit breaker	
10	External air dampers end run	Always
11	Humidifier alarm	
12	Electric coil circuit breaker	
13	Coil first pump circuit breaker	
14	Coil second pump circuit breaker	
15	Exchanger pressure switch (anti-freeze)	
16	Flow air flow switch	
17	Return air flow switch	
18	Fire/smoke	

5.1.3 DO parameters I/O table

DO		
Code	Description	Notes
0	Disabled	
1	Supply fan V1 (abi.)	
2	Flow FAN v2	
3	Flow fan V3	
4	Return fan V1 (abi.)	
5	Return fan V2	
6	Return fan V3	
7	External air dampers	
8	Recovery device bypass	
9	Humidifier	
10	Electric coil 1	
11	Electric coil 2	
12	Condenser ON-OFF	
13	RH coil first step	
14	RH coil second step	
15	Alarm repetition	
16	Summer-Winter switch-over	
17	Coil first pump command	
18	Coil second pump command	

5.1.4 AO parameters I/O table

AO		
Code	Description	Notes
0	Disabled	
1	Vmix first coil	
2	Vmix second coil	
3	Flow fan	
4	Return fan	
5	Mixing chamber dampers	
6	Humidifier	
7	Electric coil	
8	Rotating heat recovery device	

6 Regulations

6.1 Machine status

Several procedures exist for switching the unit ON and OFF:

Using the dedicated ON/OFF key (this function is enabled via parameter PH05).

Switching ON – Press the dedicated key for about 2 seconds: If all other enabled functions are present, the machine will switch on by itself

Switching OFF – Press the dedicated key for about 2 seconds: the machine switches itself OFF.

Using the ON/OFF command from digital input (this function is enabled via parameter PH07).

Switching ON – Close the remote ON/OFF contact: If all other enabled functions are present, the machine will switch on by itself

Switching OFF – If the remote ON/OFF contact reveals itself to be open, the machine switches itself "OFF from digital input, indicated by "OFF D".

Using a supervisory protocol (this function is enabled via parameter PH09).

Switching ON – Activate via protocol the switching ON status: If all other enabled functions are present, the machine will switch on by itself

Switch-off – if switch-on status is deactivated from protocol, the machine will switch-off from supervision protocol, indicated by "OFF S".

Using a schedule (this function is enabled via parameter PH04).

Switching ON – If the date and time of the RTC indicates an ON status: if all other enabled functions are present, the machine switches itself ON.

Switching OFF – If the date and time of the RTC indicates an OFF status; the machine switches itself OFF.

OFF statuses from digital input, supervisory protocol and schedule are only accessible if the machine has been enabled by key press.

The machine ON/OFF key is the ESC key.

6.2 Alarm OFF status

When the machine is turned on an additional status, **OFF from alarm (Alarm Off) exists**. This shuts down the unit, all devices, and closes the external air shutters completely until the alarm conditions are restored.

The central alarm will shut down to OFF status if there is no digital / supervisor consent or shut down is requested via the keyboard. The alarms which provoke this status are as follows:

- Fan alarms
- Air Flow Meter alarm
- Fire/smoke alarm

Once alarm conditions have been restored the machine will return to normal operation.

6.3 Unit type

While the machine is turned off, using the parameter **PG00** in the CONFIGURATION Menu, it is possible to choose the type of unit that you wish to utilize. Based on the value of the parameters, different defaults become available for the positioning of inputs and outputs.

The control and other parameters which correspond to functionalities can be modified manually according to user requirements. The machines and their configurations are described graphically in the next paragraphs.

Note: the default configurations can also be modified according to user requirements by entering modifications to the parameters manually.

CAUTION!

If the type of machine is changed (modifying the parameter PG00), the controller must successively be switched off and back on again, in order to allow correct reconfiguration of the same. Moreover, it is advised to wait for a few moments (approx 3 seconds) to assign all parameters that have been modified.

6.4 Electric connections

6.4.1 Machine electric connections with double flow

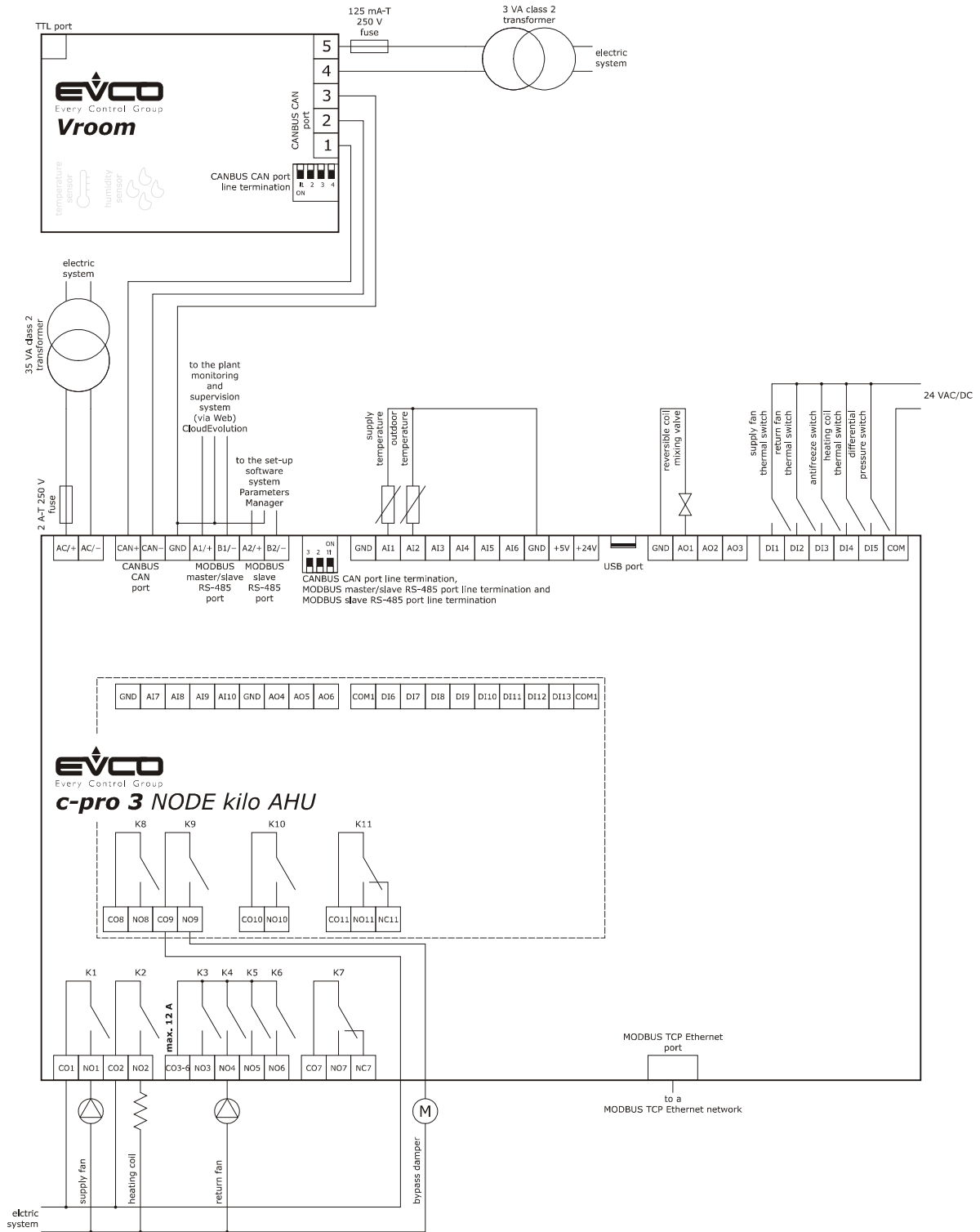

c-pro 3 NODE kilo AHU - Double flow unit with ON-OFF ventilation (Water-Electric)	
I/O	Description
Analogue inputs	
AI 1	Flow Temperature
AI 2	External temperature
AI 3	<i>Not used</i>
AI 4	<i>Not used</i>
AI 5	<i>Not used</i>
AI 6	<i>Not used</i>
AI 7	<i>Not used</i>
AI 8	<i>Not used</i>
AI 9	<i>Not used</i>
Serial ports	
Rs485	RS485 modbus RTU (on RJ45)
CANbus	to c-pro 3 NODE kilo AHU
Digital inputs (ON-OFF 24V)	
DI 1	Flow fan circuit breaker
DI 2	Return fan circuit breaker
DI 3	Antifreeze thermostat
DI 4	Electric coil circuit breaker
DI 5	Heat exchanger pressure switch
DI 6	<i>Not used</i>
DI 7	<i>Not used</i>
DI 8	<i>Not used</i>
DI 9	<i>Not used</i>
Analogue outputs	
AO 1	Vmix first coil
AO 2	<i>Not used</i>
AO 3	<i>Not used</i>
AO 4	<i>Not used</i>
AO 5	<i>Not used</i>
AO 6	<i>Not used</i>
Digital Outputs (Relay)	
DO 1	Flow fan V1
DO 2	Electric coil 1
DO 3	<i>Not used</i>
DO 4	Return fan V1
DO 5	<i>Not used</i>
DO 6	<i>Not used</i>
DO 7	<i>Not used</i>
DO 8	<i>Not used</i>
DO 9	<i>Recovery unit BY-PASS</i>

6.5 Electric connections

6.5.1 Machine electric connections with single flow

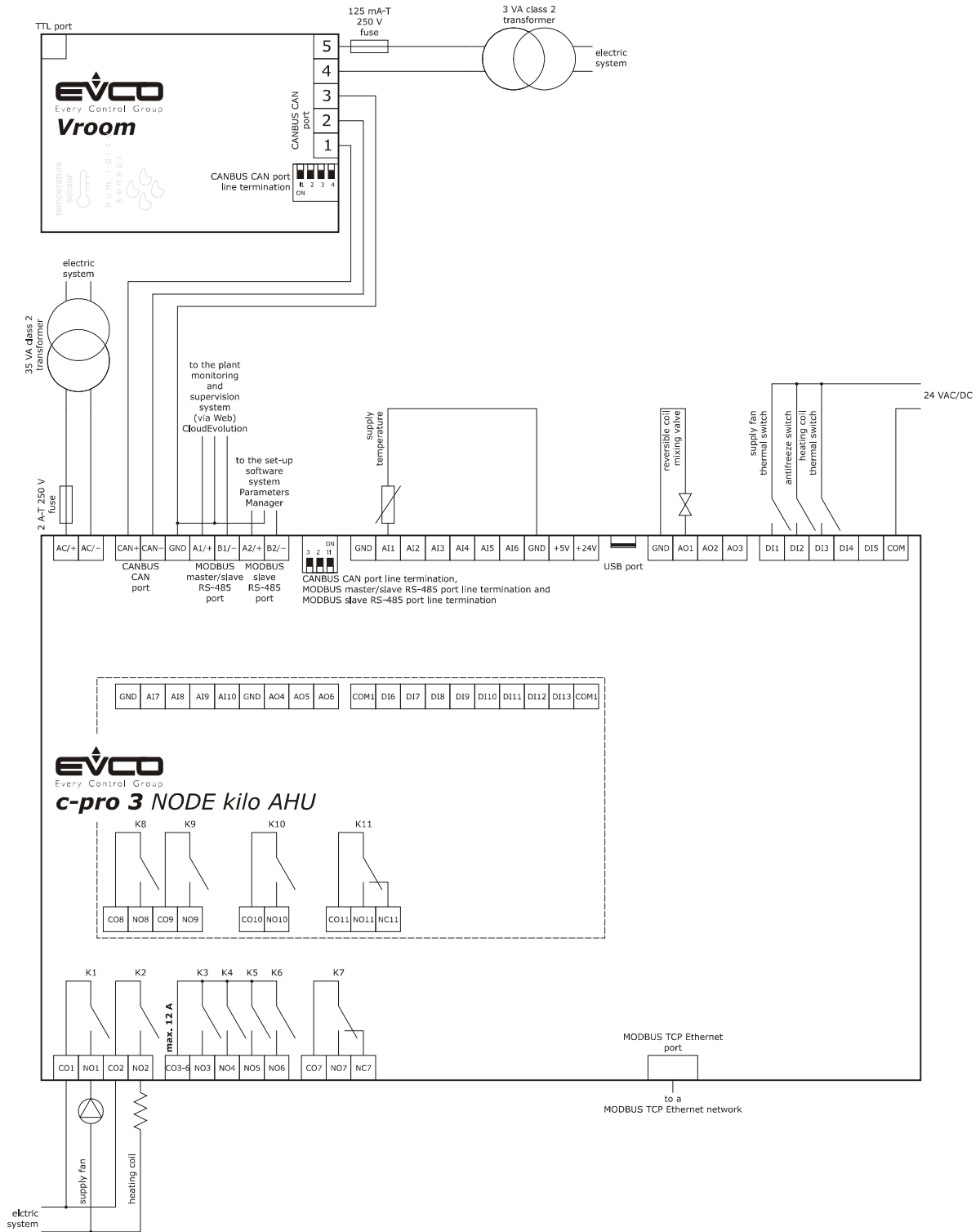

c-pro 3 NODE kilo AHU – Single flow unit with ON-OFF ventilation (Water-Electric)	
I/O	Description
Analogue inputs	
AI 1	Flow Temperature
AI 2	<i>Not used</i>
AI 3	<i>Not used</i>
AI 4	<i>Not used</i>
AI 5	<i>Not used</i>
AI 6	<i>Not used</i>
AI 7	<i>Not used</i>
AI 8	<i>Not used</i>
AI 9	<i>Not used</i>
Serial ports	
Rs485	RS485 modbus RTU (on RJ45)
CANbus	to c-pro 3 NODE kilo AHU
Digital inputs (ON-OFF 24V)	
DI 1	Flow fan circuit breaker
DI 2	Antifreeze thermostat
DI 3	Electric coil circuit breaker
DI 4	<i>Not used</i>
DI 5	<i>Not used</i>
DI 6	<i>Not used</i>
DI 7	<i>Not used</i>
DI 8	<i>Not used</i>
DI 9	<i>Not used</i>
Analogue outputs	
AO 1	Vmix first coil
AO 2	<i>Not used</i>
AO 3	<i>Not used</i>
AO 4	<i>Not used</i>
AO 5	<i>Not used</i>
AO 6	<i>Not used</i>
Digital Outputs (Relay)	
DO 1	Flow fan V1
DO 2	Electric coil 1
DO 3	<i>Not used</i>
DO 4	<i>Not used</i>
DO 5	<i>Not used</i>
DO 6	<i>Not used</i>
DO 7	<i>Not used</i>
DO 8	<i>Not used</i>
DO 9	<i>Not used</i>

6.6 Operating mode control

The operating modes can assume the following values:

Parameter "MOdE"	Description
0=COOL - SUMMER	Summer operation
1=HEAT - WINTER	Winter operation

There are additional procedures which allow you to set the operating mode of the unit:

- Using the **MOdE parameter** in the user menu (function enabled by parameter PH06).
Set – Positioned on the ModE parameter, press the ENTER key, modify the values using the UP and DOWN keys. Confirm by pressing the ENTER key again.
- Using the **supervision protocol** (enabled by using parameter PH10)
Setting – Send the operational mode change control from protocol, via the relative status.
- Via **the automatic Change-over function** (this function is enabled via parameter PHxx). Setting – When the outdoor air temperature or the discharge temperature (parameter PC63) value exceeds the Summer Commutation Set Point PC61, the unit commutates to summer operating mode. Conversely, when the outdoor air temperature value falls below the Winter Commutation Set Point PC62, the unit commutates to winter operating mode.

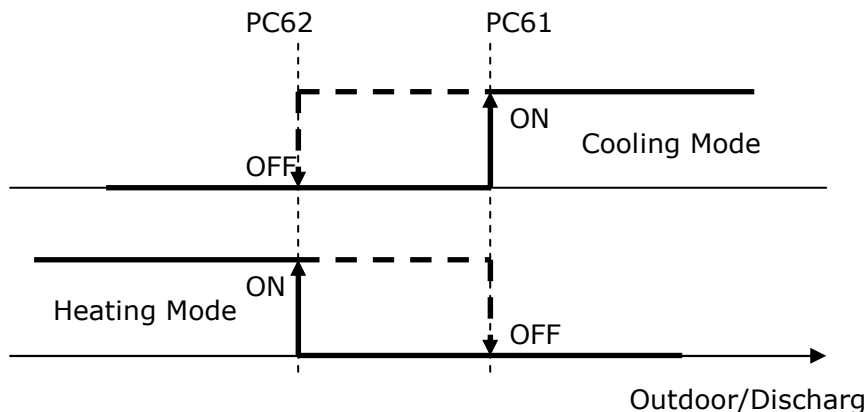

Note: It is advisable to carry out the change the summer/winter operating modes while the machine is shut down.

- By pressing a combination of keys from the page of the application (LEFT and RIGHT held down for 3 seconds).

6.7 Setting the RTC

When the power supply is disconnected from the controller for a few days, the RTC (Real Time Clock) system clock loses its time. When the controller power is up again, it requires setting the correct date and time. In this case, upon machine start-up the following page will appear allowing to set the time:

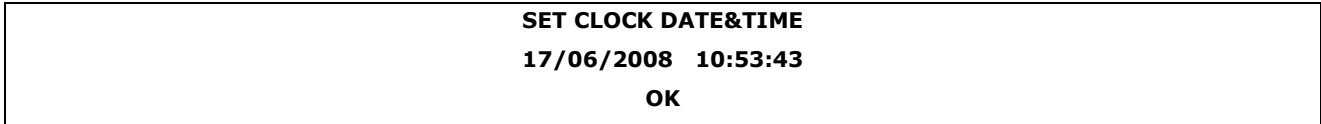

Once the clock has been configured, press **OK** to update the RTC time. The main application page will be shown. Pressing **OK** to confirm the reset of the clock alarm (ERTC) at which point the conditions of the alarm has been restored.

In case the alarm doesn't disappear: remove and reconnect the power of the controller and then manually reset the alarm.

Note: This function is enabled only if the parameter *PG03=1*, that is, if the system clock is enabled.

6.8 Plant set-up

6.8.1 Set-up of the heat recovery device

The screens that allow to configure the plant are shown below graphically



Screen from where it is possible to set the SETUP of the heat recovery device, confirming the activation via "Yes" or deactivation with "No".

6.8.2 Set-up of the fans

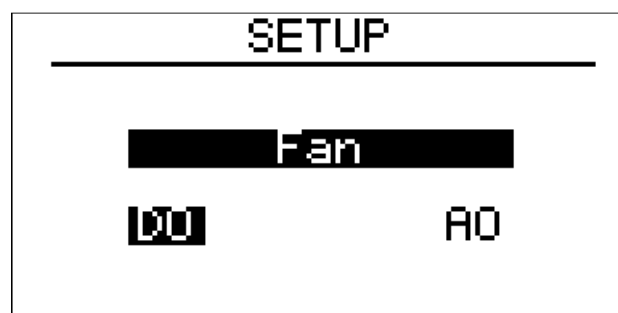

Screen from where it is possible to set the SETUP of the fans, activating with "DO" if from digital output or "AO" if from analogue output.

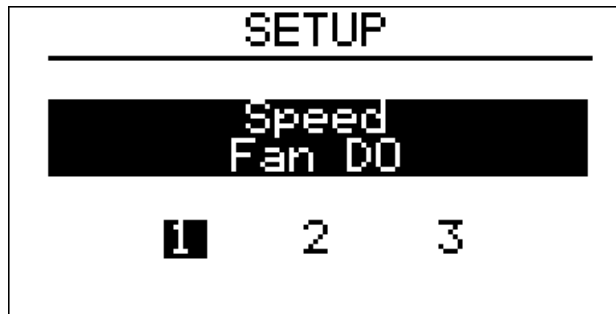

If entered from "DO" therefore digital output, I can proceed at a determined fan speed (Speed Fan DO), activating 1, 2 or 3.

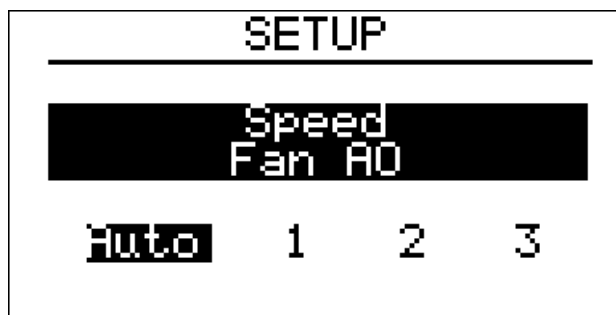

If entered from "AO" therefore analogue output, I can proceed with determined fan speed (Speed Fan AO), activating the automatic mode with "Auto" or 1, 2 or 3 depending on the desired speed.

6.8.3 Set up of Coil 1 type configuration

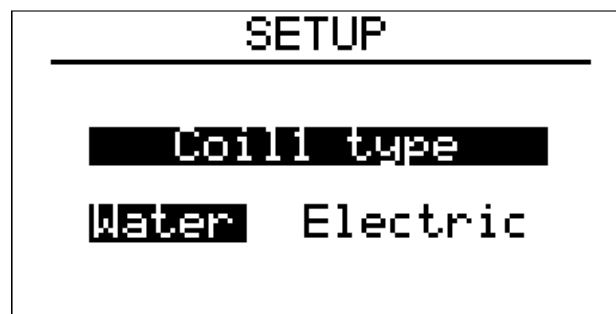

Screen from which the coil type can be configured (Coil 1 type), selecting with "Water" if water is chosen or selecting "Electric" in the case of heaters.

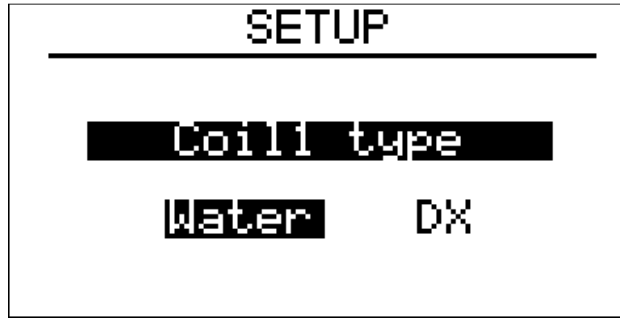

Screen from which the coil type can be configured (Coil 1 type), selecting with "Water" if water is chosen or selecting "RH" in the case of direct expansion.



If selected as coil type 1, water, I can select the method (Coil 1 mode) with which to manage: with "Cold" with cold water, "Hot" for hot water or "Mix" for hot/cold water.

If the previous screens had selected a coil 1 type, with direct expansion (RH), I can proceed selecting the steps (see screen below)



6.8.4 Set up of Coil 2 type configuration

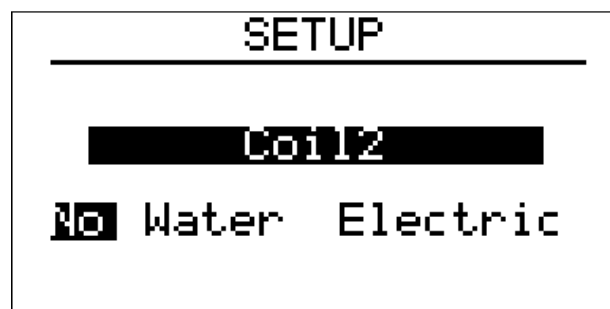

Screen from where it is possible to configure coil 2, selecting with "No" for not present, "Water" to select with water and finally the possibility to select "Electric" if heating elements are chosen.

If "Electric" has been chosen, the following screen will appear:



Where successively the type of heating elements I am interested in can be selected: "DO1", "DO" in the case of digital heating elements or "AO", if analogue

To confirm and apply the configuration just set, proceed confirming "Yes" below the wording "Setup complete Apply?"



If everything has gone well, i.e. the parameters have been configured correctly, the screen that will display is that represented below. "Parameters set correctly"

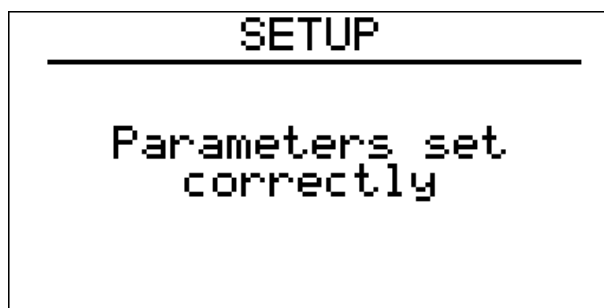

6.9 Table of types of configurable machines

Once the parameters are set wizard, you have configured one of 153 possible machines.

The following table shows the machines with configurable drive type to DOUBLE FLOW:

Machine DOUBLE FLOW				
Code	Unit Type	Fans Type	Coil 1 type	Coil 2 type
1	Double flow	ON-OFF	Water (C)	NO
2	Double flow	ON-OFF	Water (C)	Water (H)
3	Double flow	ON-OFF	Water (C)	Electrical 1st
4	Double flow	ON-OFF	Water (C)	Electrical 2st
5	Double flow	ON-OFF	Water (C)	Electrical mod
6	Double flow	ON-OFF	Water (H/C)	NO
7	Double flow	ON-OFF	Water (H/C)	Water (H)
8	Double flow	ON-OFF	Water (H/C)	Electrical 1st
9	Double flow	ON-OFF	Water (H/C)	Electrical 2st
10	Double flow	ON-OFF	Water (H/C)	Electrical mod
11	Double flow	ON-OFF	Water (H)	NO
12	Double flow	ON-OFF	Water (H)	Electrical 1st
13	Double flow	ON-OFF	Water (H)	Electrical 2st
14	Double flow	ON-OFF	Water (H)	Electrical mod
15	Double flow	ON-OFF	Electrical 1st	NO
16	Double flow	ON-OFF	Electrical 2st	NO
17	Double flow	ON-OFF	Electrical mod	NO
18	Double flow	3 Speed	Water (H)	NO
19	Double flow	3 Speed	Water (H)	Water (H)
20	Double flow	3 Speed	Water (H)	Electrical 1st
21	Double flow	3 Speed	Water (H)	Electrical 2st
22	Double flow	3 Speed	Water (C)	Electrical mod
23	Double flow	3 Speed	Water (H/C)	NO
24	Double flow	3 Speed	Water (H/C)	Water (H)
25	Double flow	3 Speed	Water (H/C)	Electrical 1st
26	Double flow	3 Speed	Water (H/C)	Electrical 2st
27	Double flow	3 Speed	Water (H/C)	Electrical mod
28	Double flow	3 Speed	Water (H)	NO
29	Double flow	3 Speed	Water (H)	Electrical 1st
30	Double flow	3 Speed	Water (H)	Electrical 2st
31	Double flow	3 Speed	Water (H)	Electrical mod
32	Double flow	3 Speed	Electrical 1st	NO
33	Double flow	3 Speed	Electrical 2st	NO
34	Double flow	3 Speed	Electrical mod	NO
35	Double flow	Modulating	Water (C)	NO
36	Double flow	Modulating	Water (C)	Water (H)
37	Double flow	Modulating	Water (C)	Electrical 1st
38	Double flow	Modulating	Water (C)	Electrical 2st
39	Double flow	Modulating	Water (C)	Electrical mod
40	Double flow	Modulating	Water (H/C)	NO
41	Double flow	Modulating	Water (H/C)	Water (H)
42	Double flow	Modulating	Water (H/C)	Electrical 1st

43	Double flow	Modulating	Water (H/C)	Electrical 2st
44	Double flow	Modulating	Water (H/C)	Electrical mod
45	Double flow	Modulating	Water (H)	NO
46	Double flow	Modulating	Water (H)	Electrical 1st
47	Double flow	Modulating	Water (H)	Electrical 2st
48	Double flow	Modulating	Water (H)	Electrical mod
49	Double flow	Modulating	Electrical 1st	NO
50	Double flow	Modulating	Electrical 2st	NO
51	Double flow	Modulating	Electrical mod	NO

The following table shows the machines with configurable drive type to SINGLE FLOW:

Code	Unit Type	Fans Type	Coil 1 type	Coil 2 type
52	Single flow	ON-OFF	Water (C)	NO
53	Single flow	ON-OFF	Water (C)	Water (H)
54	Single flow	ON-OFF	Water (C)	Electrical 1st
55	Single flow	ON-OFF	Water (C)	Electrical 2st
56	Single flow	ON-OFF	Water (C)	Electrical mod
57	Single flow	ON-OFF	Water (H/C)	NO
58	Single flow	ON-OFF	Water (H/C)	Water (H)
59	Single flow	ON-OFF	Water (H/C)	Electrical 1st
60	Single flow	ON-OFF	Water (H/C)	Electrical 2st
61	Single flow	ON-OFF	Water (H/C)	Electrical mod
62	Single flow	ON-OFF	Water (H)	NO
63	Single flow	ON-OFF	Water (H)	Electrical 1st
64	Single flow	ON-OFF	Water (H)	Electrical 2st
65	Single flow	ON-OFF	Water (H)	Electrical mod
66	Single flow	ON-OFF	DX (C,1st)	NO
67	Single flow	ON-OFF	DX (C,2st)	NO
68	Single flow	ON-OFF	DX (C,1st)	Water (H)
69	Single flow	ON-OFF	DX (C,2st)	Water (H)
70	Single flow	ON-OFF	DX (C,1st)	Electrical 1st
71	Single flow	ON-OFF	DX (C,2st)	Electrical 1st
72	Single flow	ON-OFF	DX (C,1st)	Electrical 2st
73	Single flow	ON-OFF	DX (C,2st)	Electrical 2st
74	Single flow	ON-OFF	DX (C,1st)	Electrical mod
75	Single flow	ON-OFF	DX (C,2st)	Electrical mod
76	Single flow	ON-OFF	DX (H/C,1st)	NO
77	Single flow	ON-OFF	DX (H/C 2st)	NO
78	Single flow	ON-OFF	DX (H/C,1st)	Water (H)
79	Single flow	ON-OFF	DX (H/C,2st)	Water (H)
80	Single flow	ON-OFF	DX (H/C,1st)	Electrical 1st
81	Single flow	ON-OFF	DX (H/C,2st)	Electrical 1st
82	Single flow	ON-OFF	DX (H/C,1st)	Electrical 2st
83	Single flow	ON-OFF	DX (H/C,2st)	Electrical 2st
84	Single flow	ON-OFF	DX (H/C,1st)	Electrical mod
85	Single flow	ON-OFF	DX (H/C,2st)	Electrical mod
86	Single flow	3 Speed	Water (C)	NO
87	Single flow	3 Speed	Water (C)	Water (H)
88	Single flow	3 Speed	Water (C)	Electrical 1st
89	Single flow	3 Speed	Water (C)	Electrical 2st
90	Single flow	3 Speed	Water (C)	Electrical mod
91	Single flow	3 Speed	Water (H/C)	NO
92	Single flow	3 Speed	Water (H/C)	Water (H)
93	Single flow	3 Speed	Water (H/C)	Electrical 1st
94	Single flow	3 Speed	Water (H/C)	Electrical 2st

95	Single flow	3 Speed	Water (H/C)	Electrical mod
96	Single flow	3 Speed	Water (H)	NO
97	Single flow	3 Speed	Water (H)	Electrical 1st
98	Single flow	3 Speed	Water (H)	Electrical 2st
99	Single flow	3 Speed	Water (H)	Electrical mod
100	Single flow	3 Speed	DX (C,1st)	NO
101	Single flow	3 Speed	DX (C,2st)	NO
102	Single flow	3 Speed	DX (C,1st)	Water (H)
103	Single flow	3 Speed	DX (C,2st)	Water (H)
104	Single flow	3 Speed	DX (C,1st)	Electrical 1st
105	Single flow	3 Speed	DX (C,2st)	Electrical 1st
106	Single flow	3 Speed	DX (C,1st)	Electrical 2st
107	Single flow	3 Speed	DX (C,2st)	Electrical 2st
108	Single flow	3 Speed	DX (C,1st)	Electrical mod
109	Single flow	3 Speed	DX (C,2st)	Electrical mod
110	Single flow	3 Speed	DX (H/C,1st)	NO
111	Single flow	3 Speed	DX (H/C,2st)	NO
112	Single flow	3 Speed	DX (H/C,1st)	Water (H)
113	Single flow	3 Speed	DX (H/C,2st)	Water (H)
114	Single flow	3 Speed	DX (H/C,1st)	Electrical 1st
115	Single flow	3 Speed	DX (H/C,2st)	Electrical 1st
116	Single flow	3 Speed	DX (H/C,1st)	Electrical 2st
117	Single flow	3 Speed	DX (H/C,2st)	Electrical 2st
118	Single flow	3 Speed	DX (H/C,1st)	Electrical mod
119	Single flow	3 Speed	DX (H/C,2st)	Electrical mod
120	Single flow	Modulating	Water (C)	NO
121	Single flow	Modulating	Water (C)	Water (H)
122	Single flow	Modulating	Water (C)	Electrical 1st
123	Single flow	Modulating	Water (C)	Electrical 2st
124	Single flow	Modulating	Water (C)	Electrical mod
125	Single flow	Modulating	Water (H/C)	NO
126	Single flow	Modulating	Water (H/C)	Water (H)
127	Single flow	Modulating	Water (H/C)	Electrical 1st
128	Single flow	Modulating	Water (H/C)	Electrical 2st
129	Single flow	Modulating	Water (H/C)	Electrical mod
130	Single flow	Modulating	Water (H)	NO
131	Single flow	Modulating	Water (H)	Electrical 1st
132	Single flow	Modulating	Water (H)	Electrical 2st
133	Single flow	Modulating	Water (H)	Electrical mod
134	Single flow	Modulating	DX (C,1st)	NO
135	Single flow	Modulating	DX (C,2st)	NO
136	Single flow	Modulating	DX (C,1st)	Water (H)
137	Single flow	Modulating	DX (C,2st)	Water (H)
138	Single flow	Modulating	DX (C,1st)	Electrical 1st
139	Single flow	Modulating	DX (C,2st)	Electrical 1st
140	Single flow	Modulating	DX (C,1st)	Electrical 2st

141	Single flow	Modulating	DX (C,2st)	Electrical 2st
142	Single flow	Modulating	DX (C,1st)	Electrical mod
143	Single flow	Modulating	DX (C,2st)	Electrical mod
144	Single flow	Modulating	DX (H/C,1st)	NO
145	Single flow	Modulating	DX (H/C,2st)	NO
146	Single flow	Modulating	DX (H/C,1st)	Water (H)
147	Single flow	Modulating	DX (H/C,2st)	Water (H)
148	Single flow	Modulating	DX (H/C,1st)	Electrical 1st
149	Single flow	Modulating	DX (H/C,2st)	Electrical 1st
150	Single flow	Modulating	DX (H/C,1st)	Electrical 2st
151	Single flow	Modulating	DX (H/C,2st)	Electrical 2st
152	Single flow	Modulating	DX (H/C,1st)	Electrical mod
153	Single flow	Modulating	DX (H/C,2st)	Electrical mod

Depending on the configured machine, it will be pre-populated table I/O by assigning the appropriate value (based on the tables at the hardware parameters HA, HB, HC and HD).

In the tables that follow are the possible configurations of I/O by default for machines with DOUBLE FLOW and machines SINGLE FLOW.

6.10 Fans

The air handling unit can control two fans, one supply fan and one return fan. Both fans are controlled in the same fashion; the type of control is set by the parameter PF01 (Continuous Control, Continuous/On Off Control, On/Off Control, Modulating control, Modulating control with steps to enable, Static pressure control).

Supply fan and return fan can be enabled in the CONFIGURATION Menu using the parameters PG08 and PG09.

Fans are controlled by the room temperature sensor using a set point and a differential value.

With parameter PF05 = Minimum time between fan start-up and shutdown of supply and return fans, it is possible to define a time delay between the start-up of the supply and return fan, and the shutdown of them.

PF01: control mode fans

PG08: enable return fan

PG09: enable supply fan

PF05: Minimum time between fan start-up

6.10.1 Continuous control

The continuous control is connected to the status of the air handling unit; the fans turn on and off every time the machine is turned on and off. In order to set this control select PF01=0.

6.10.2 Continuous/On Off control

During summer the controller uses continuous control, otherwise in winter the control is On/Off type. In order to set this control select PF01=1.

6.10.3 Control On/Off

The On/Off control provides ability to switch on or off fans depending on the room temperature.

The room temperature is compared with the control Set point (SEtC, SEtH) and a differential (PF02), see also the figures below.

In order to enable this control select PF01=2.

Each mode of operation (summer/winter) has its own distinct control.

SUMMER operating mode

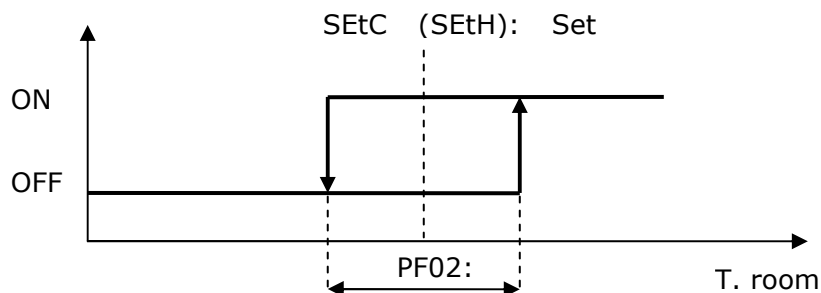

WINTER operating mode

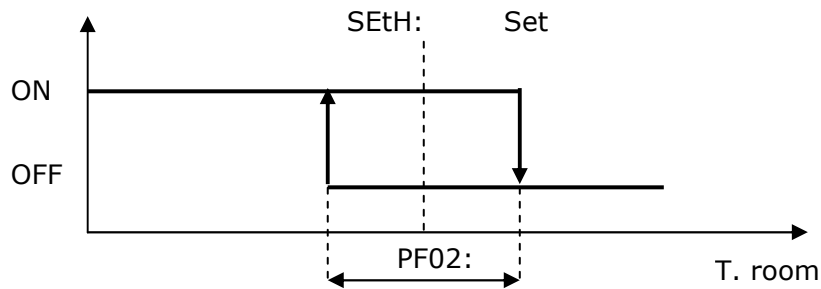

6.10.4 Modulating regulation

Generally controlled by an inverter, it carries out a refined heating function: “winter operating mode” or cooling function: “summer operating mode”. This control mode is focused on saving energy.

The variable fan speed is controlled by the room temperature sensor. The control set point (*SEtC*, *SEtH*) and the proportional band (*PF02*) needs to be defined, see also the figures below. In order to enable this control select *PF01=3*.

Alternatively the variable fan speed can be controlled by the discharge air temperature sensor (*PF07*).

Each mode of operation (summer/winter) has its own distinct control.

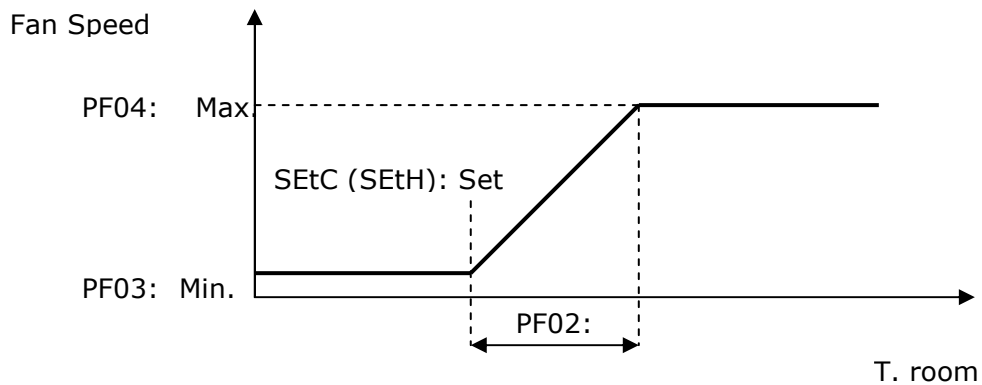

SUMMER operating mode WINTER operating mode

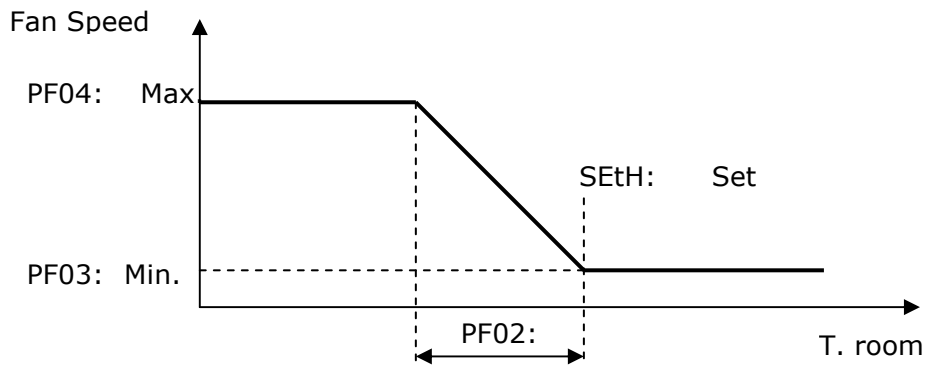

The fan speed is identical for both flow and return fans.

- PF01*: control mode fans
- PF02*: control band
- PF03*: Minimum fan speed
- PF04*: maximum fan speed
- PF07*: Control temperature (room temperature, discharge air temperature)

6.10.5 Modulating control with steps to enable

The same logic for the modulating control applies with the additional possibility of shutting down the fan with a specific step on the control ramp. For this control select *PF01*=4.

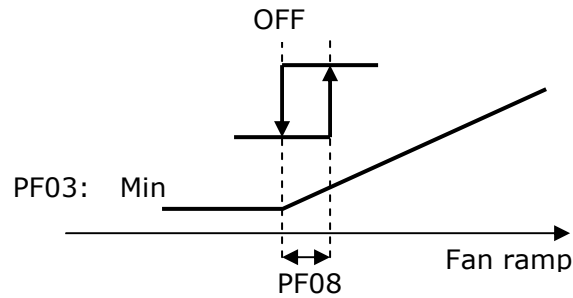

The fan switch off point corresponds to the value of the room temperature control set point. The fan switch on and off commands are delayed in order to avoid high currents (parameter *PF09*).

Alternatively the variable fan speed can be controlled by the discharge air temperature sensor (*PF07*).

The fan speed is identical for both flow and return fans.

- PF01*: control mode fans
- PF03*: Minimum fan speed
- PF07*: Control temperature (room temperature, discharge air temperature)
- PF08*: Differential of On/Off steps on ramp of control of fan modules
- PF09*: Delay time (on and off) of On/Off steps on ramp of control of fan modules

6.10.6 Static Pressure control

When a discharge air static pressure is connected to the controller it is possible to control the fans based on the discharge air static pressure. The discharge air static pressure is proportionally integral (PI) controlled.

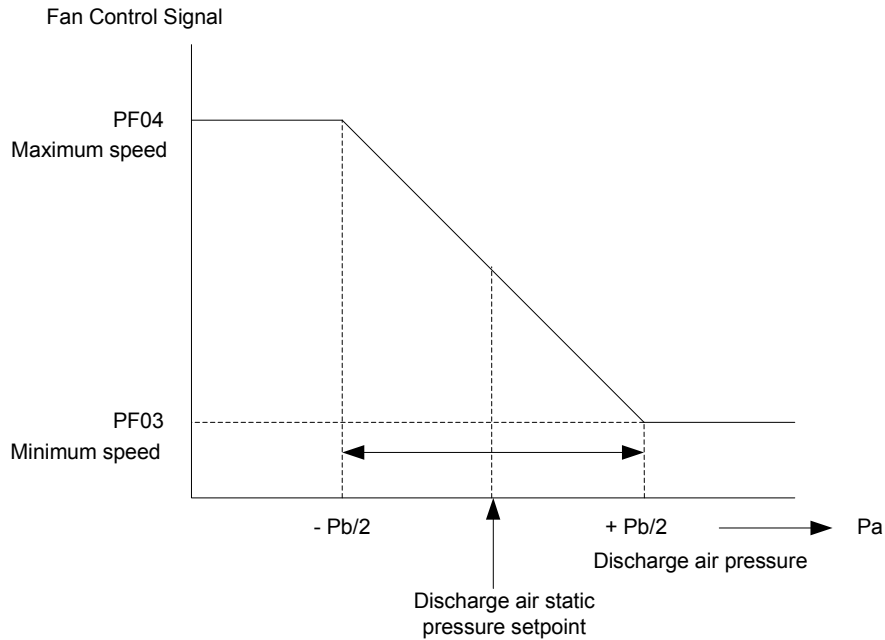

The discharge air static pressure set point is smoothly ramped from 0 to its target set point when the central unit is started. The ramp time is defined by parameter PF11, static pressure control set point ramp.

PF01: control mode fans

PF03: Minimum fan speed

PF04: maximum fan speed

P11 Static pressure control set point ramp

P12 Static pressure control set point

P13: Static pressure control proportional band

P14: Static pressure control integral time

PH48: Enable Static pressure sensor

PH01: Minimum value threshold for the pressure sensor

PH02: Maximum value threshold for the pressure sensor.

The fan speed is identical for both flow and return fans.

6.10.7 Minimum/Maximum discharge temperature

When the discharge temperature exceeds the maximum or minimum set of parameters PF16 or PF17 the ventilation is disabled.

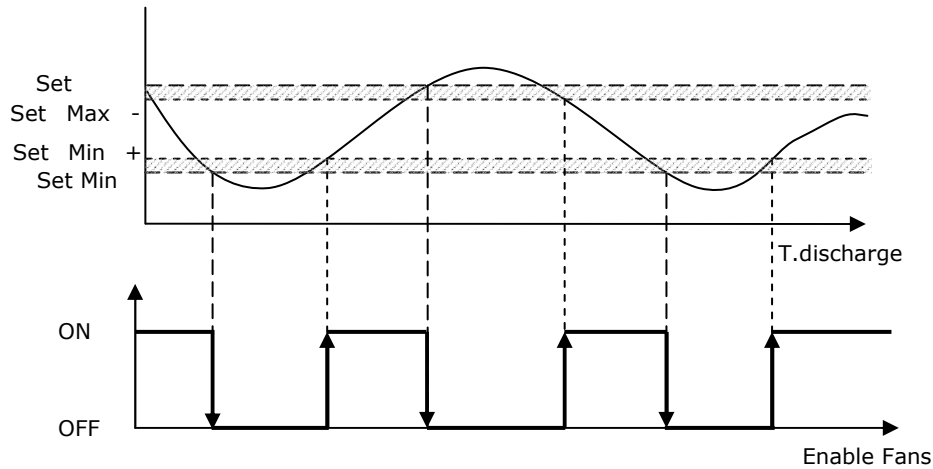

PF15: Enable fan limitation

PF16: Min. temperature of limitation

PF17: Max. temperature of limitation

PF18: Differential

6.10.8 "Intake cycles"

When the temperature control sensor is positioned in the return duct (*PG05=1*), it is necessary to activate periodically the return fan in order to measure the room temperature (parameter *PC05* to enable).

The cycle is composed of a wait time (*PC06*) during which the fan remains off as well as a wait time for activation (*PC07*) in which the fans will turn on. The cycle always begins with a period of pause; as soon as the fan is shut down from the control room temperature (satisfactory room temperature), the cycle will terminate if during the activation phase the regulation ramp of the ambient temperature exceeds the activation point of the fan. With the parameter *PC08* you can decide whether to activate only the pickup fan (*PC08=0*) or both the return and flow fans (*PC08=1*) during air quality control measuring.

Note 1: if the fan control is continuous (*PF01=0*) the air quality sensor cycle can never be activated and is thus unusable. If the return fan is not present (*PG09=0*) this function cannot be used.

Note 2: the fan activation time during the cycle (*PC07*) must be sufficiently long with respect to the protection time of the two fans (*PF05*), to ensure that both fans are able to turn on during the start-up of the air quality measuring phase (if requested, see *PC08*).

6.10.9 Fan status

Below are the different operating modes in which each fan may find itself:

1. *Disabled*: the fan has not been configured for the plant. In this status in the user interface you will see the symbol "-".
2. *Off*: the fan is off. In the user interface you will see written "ON" when in this state "OFF".
3. *On*: the fan is on. In the user interface you will see written "ON" when in this state "ON".
4. *Waiting for Start-up*: the fan is about to Start-up, and is in a temporary queue. In this status in the user interface you will see written (and flashing) "WON".
5. *Alarm*: the fan is in alarm for thermal reasons or because of the alarm inverter. In the user interface you will see written "ALARM" when in this state.
6. *Manual*: the fan is operating manually. In this status in the user interface you will see written "MANU".

A fan operating manually is nevertheless sensitive to eventual alarms; in this case the status will be that of Alarm.

6.10.10 Fan alarm inputs

Thermal fan alarms or inverter alarms can be connected to the controller. Per fan there is one digital input available.

6.10.11 Environment temperature robe in error mode

In case of a room temperature sensor failure, it is possible to define a predefined fan speed by parameter PF10.

In case where the fans are On/Off controlled, the parameter *PF10* must be set to a value greater than 0.0% in order to keep the fans in operation.

If *PF10=0.0%*, the two fans are off.

6.11 Main controls

The controller controls both temperature and humidity. Both control functions provide a Neutral Zone (parameter *Pb03* for the temperature and *PU02* for the humidity) in which there is no energy consumed. The logic for the control is shown below.

The **Control of the Temperature** works on the heating and cooling coils in order to maintain the temperature as close as possible to the set point.

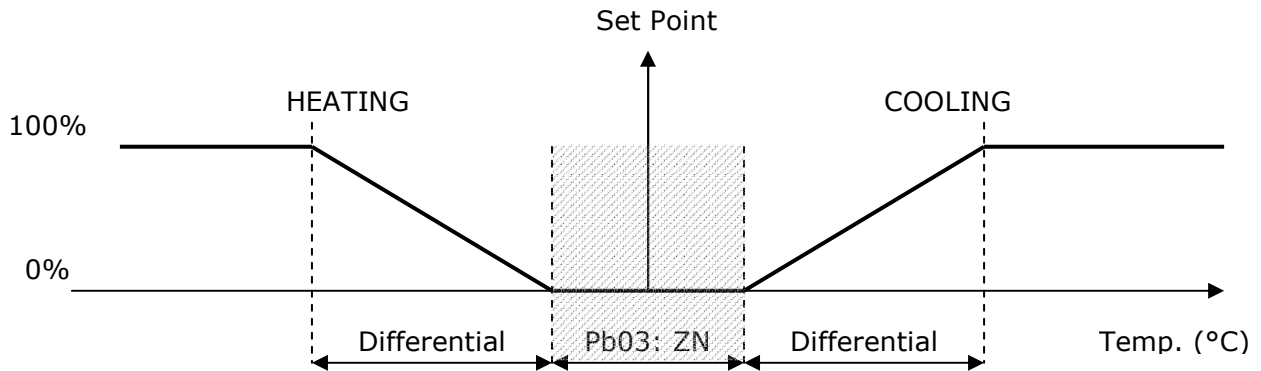

PB03: Neutral zone temperature control

The **Control of Humidity** works on the humidifier and on the process of dehumidification (utilizing the cooling coil) in order to maintain the humidity as close as possible to the set point. The humidification process can also be performed using an On-Off humidifier.

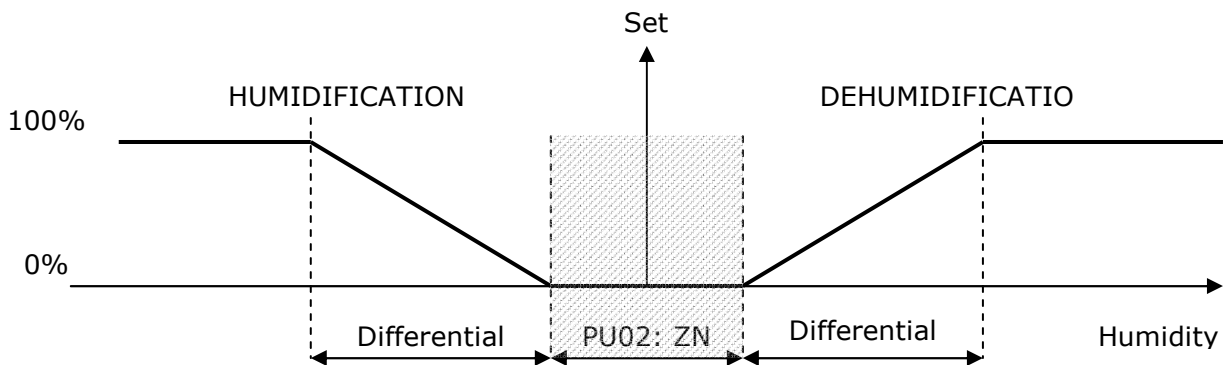

PU02: Neutral zone humidity control

Note: for both of the controls (humidity and temperature) the *Neutral Zone* is positioned around the set point. The control functions starting point are respectively: $SP+ (ZN/2)$ and $SP-(ZN/2)$.

6.12 Cooling and heating controls

When the primary control is based on the valve ($PG04=1$) it is possible to control the heating and cooling valves. The control is based on a cascade controller, the discharge air temperature set point is adjusted by the room temperature deviation. The valve is proportional algorithm (P) or a proportional integral (PI) controlled. The referenced sensor is that of the flow temperature.

Note: with the unit running on a single coil, enabling the valve will depend on the type of primary control that is chosen. If the parameter $PG04=0$, primary control on the fans, the valve remains disabled. In order to utilize you will need to set $PG04=1$ (primary control on the valve).

$PG04$: primary control mode (fan, valve)

6.12.1 Floating set point floating from flow

If the discharge air temperature sensor is present it is preferable to use an algorithm which, in relation to the shifting between set points and room temperatures, stabilizes the temperature value required for air supply and thus effects the action of the control module on the valve. The discharge air temperature set point is calculated based on the set point room temperature.

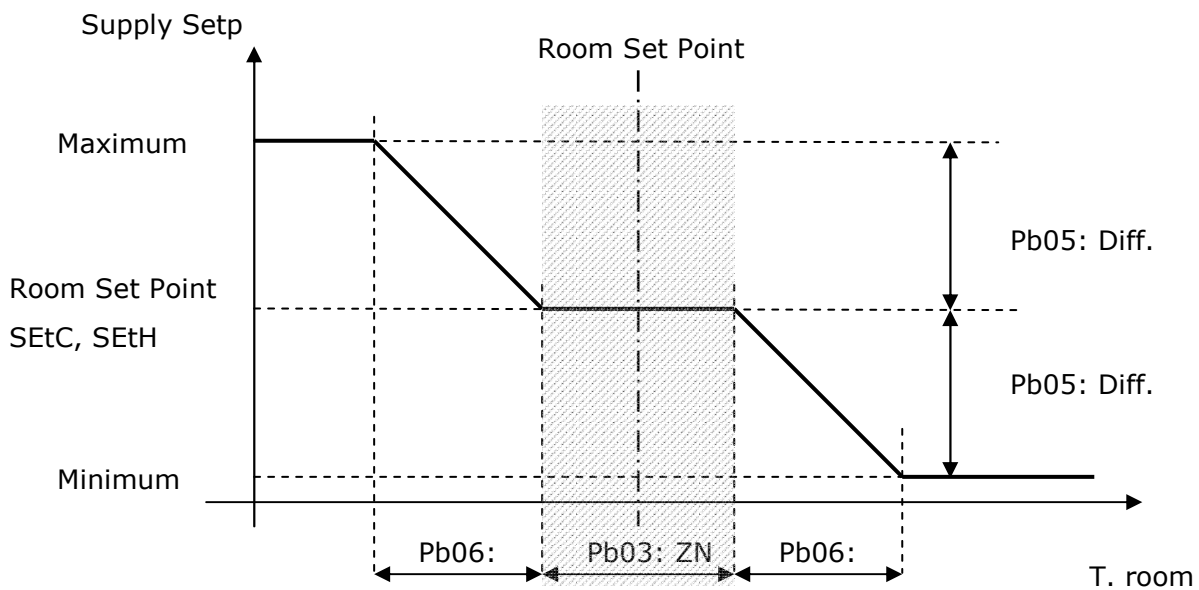

The *Minimum Limit* and the *Maximum Limit* are expressed as temperature offsets ($Pb05$) with respect to $SEtC$ ($SEtH$, if unique set point), environment regulation set point. The neutral zone is the same zone which is set for the control of the coils on the flow temperature.

Note: setting $Pb05=0.0$ the function is as if it were disabled; in this case the discharge air set point is equal to the room set point.

6.12.2 Modulating valve control

In order to utilize only a proportional control you need to only set the integral time to zero ($Pb02=0$). Setting an integral time greater than zero ($Pb02>0$) will provide a more precise control, the integral part is tasked with bringing the output up to speed reducing the error introduced by the sole proportional component (by default the integral component is disabled).

COOLING: proportional control of the cooling valve.

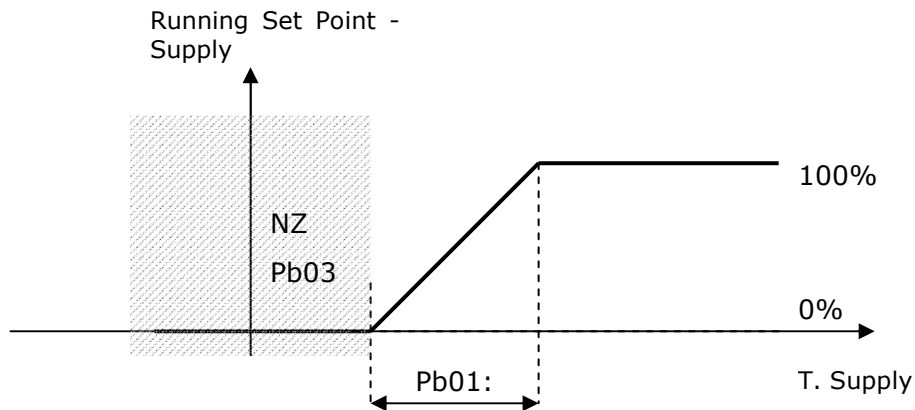

Note: the cooling valve is the same as that which is utilized for the dehumidification, thus the cooling control is also influenced by the request for dehumidification; for additional information refer to paragraph "Dehumidification control".

HEATING: proportional control of the heating valve.

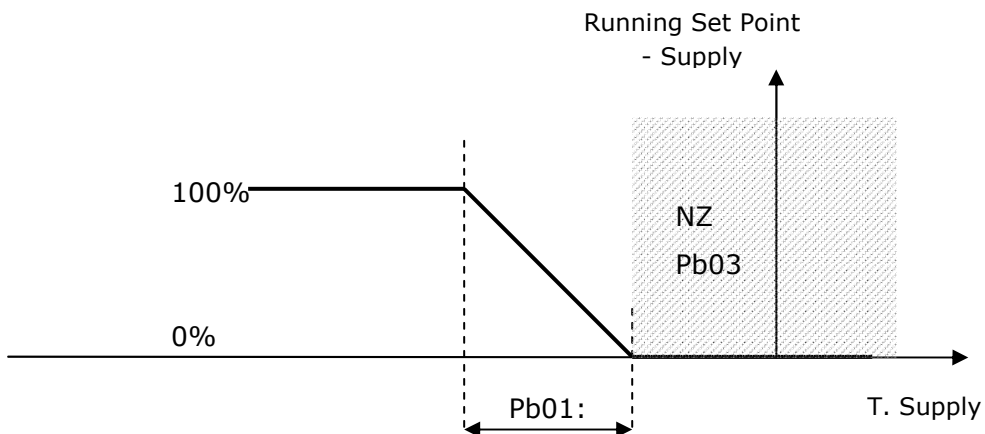

In the case where the flow sensor verifies an error it is possible to decide the value of the opening of the valve during an alarm by setting the parameters $Pb10$ and $Pb11$ equal to 0.0%. In sensor error the respective valves remain closed.

6.13 Post-heating

This may be performed using a warm water coil ($PG01=3$) or, alternatively, utilizing electrical heater ($PG14>0$). The post-heating serves two main purposes: integration of heat in heating or compensation in the dehumidification phase in order to realize the amount of heat lost (i.e. drop in temperature) during dehumidification.

The control takes place on the running flow set point and the valve can be commanded using a proportional algorithm (P), or proportional integral (PI). The referenced sensor is that of the flow temperature.

6.13.1 Post-heating coil for hot water

The third coil is used to regulate the post-heating valve in analogue mode; the control utilizes twice the heating differential ($Pb01$).

The activation graph is as follows.

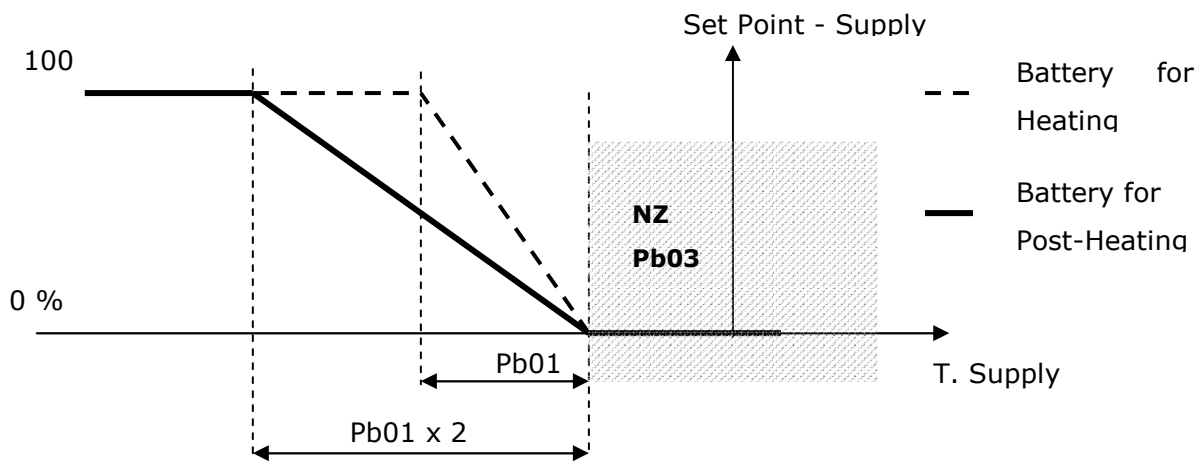

6.13.2 Electrical post heating coil

Based on the number of configured heating elements ($PG14=1, 2, 3$) double the control differential ($Pb01$) must be divided proportionally in order to guarantee uniform Start-up of each single stage of heating element.

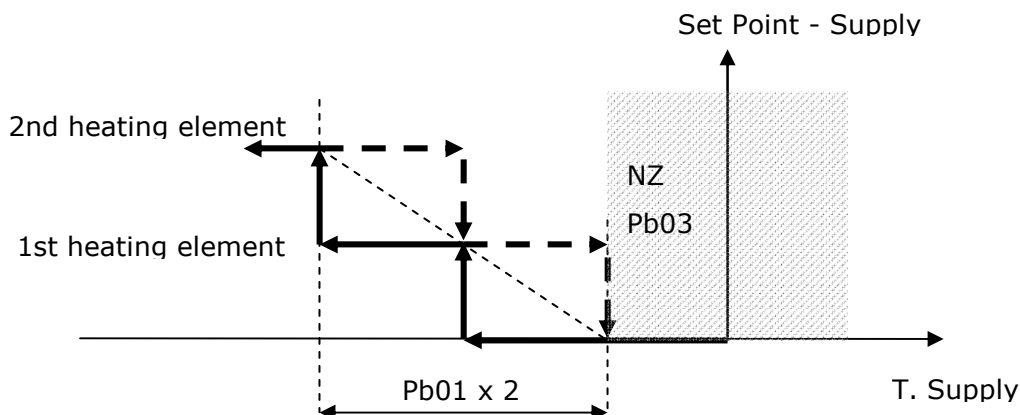

Within each insertion/removal of heating elements a certain amount of time (parameter $Pb20$) must elapse in order to avoid simultaneous occurrences.

Note: in order to exclusively utilize the heating elements for purposes of post-heating it is important to set $PG14>0$ and $PG01=2$.

6.13.3 Post-heating resistors modulating

To use the modulating resistors set the parameter PG06 = 3.

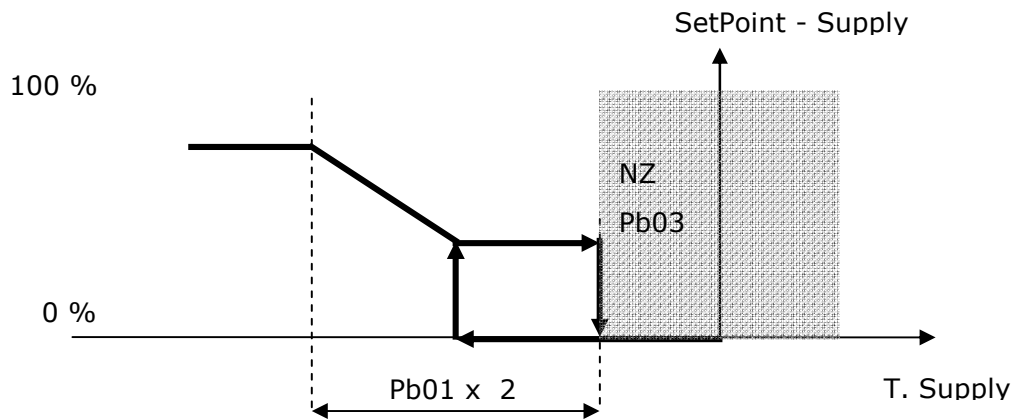

In opening the output remains at 0% as long as the request does not become greater than the parameter PB25, then takes the value of the request. In closing, the output takes the value of the request until it is greater than PB25, then is maintained at the value of PB25 until the request does not go to 0%.

6.13.4 Resistance in summer

You can use the resistance as an aid in midseason.

In this case the adjustment parameters follows PB23 and PB24.

6.13.5 Status of post-heating heating elements

Each of the three stages of the heating elements can assume one of the following operating states:

1. *Disabled*: the stage of the heating element is not managed by the controller. While in this status you will see the symbol "---" in the user interface.
2. *Off*: the stage of the heating element is off. In the user interface you will see written "ON" when in this status "OFF".
3. *Waiting for Start-up*: the stage of the heating elements is about to switch-on, and is in queue for a protection timetable. In this status in the user interface you will see written (and flashing) "WON".
4. *Waiting for shutdown*: the stage of the heating elements is about to shutdown, and is in queue for a protection timetable. In this status in the user interface you will see written (and flashing) "WOFF".
5. *On*: the stage of the heating elements is on. In the user interface you will see written "ON" when in this state "ON".
6. *Alarm*: the heating elements are blocked as a result of the relative thermal alarms. In the user interface you will see written "ALARM" when in this state.

6.14 Dehumidification

In order to adjust the comfort of the room it is necessary to also consider the humidity in the air and regulate it based on a determined desired Set point percentage ($PU01$) and at a neutral zone ($PU02$) in which the humidity conditions are acceptable and do not require any intervention. The control of the dehumidification is proportional-integral, to render it only proportional you need to only set the integral time to zero ($PU04=0$).

If the room humidity sensor is present it is possible to command a dehumidification process by utilizing the cooling coil in order to eliminate the humidity from the incoming air. Dehumidification management is enabled by activating parameter $PG12=1$, in the configuration menu.

6.14.1 Dehumidification control

The control utilizes the same cooling coil, thus implying that there are at least two configured coils ($PG01>1$). The room air humidity sensor is also activated ($PH41=1$), if the sensor is disabled or in error dehumidification management will be inhibited. Since the same coil is used for the cooling the control of dehumidification assumes the following rules:

- 1) When requesting only cooling the coil is controlled according to the logic previously seen.
- 2) When requesting only to dehumidify the coil is utilized exclusively to dehumidify the room air and is illustrated in the following graph:

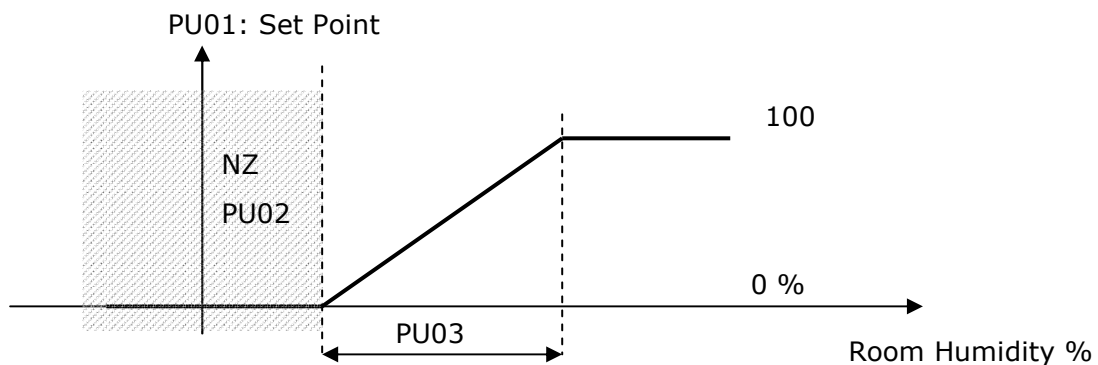

- 3) In case where the requested actions are mixed and require both dehumidification and cooling you will need to consider the average value of the two requests and the coil will be commanded with the arithmetic mean of the two values.

6.14.2 Limit regulation of dehumidification

When there is an active request for dehumidification and there is a pending request for continuous heating, this function (enabled by parameter $PU05=1$) allows for limiting the cooling valve opening to dehumidify in order to contrast the continuous decrease in temperature (required by the dehumidification) and rapidly returning to the desired conditions in temperature.

This action has a more immediate effect on temperature and allows for energy savings, optimizing coil control.

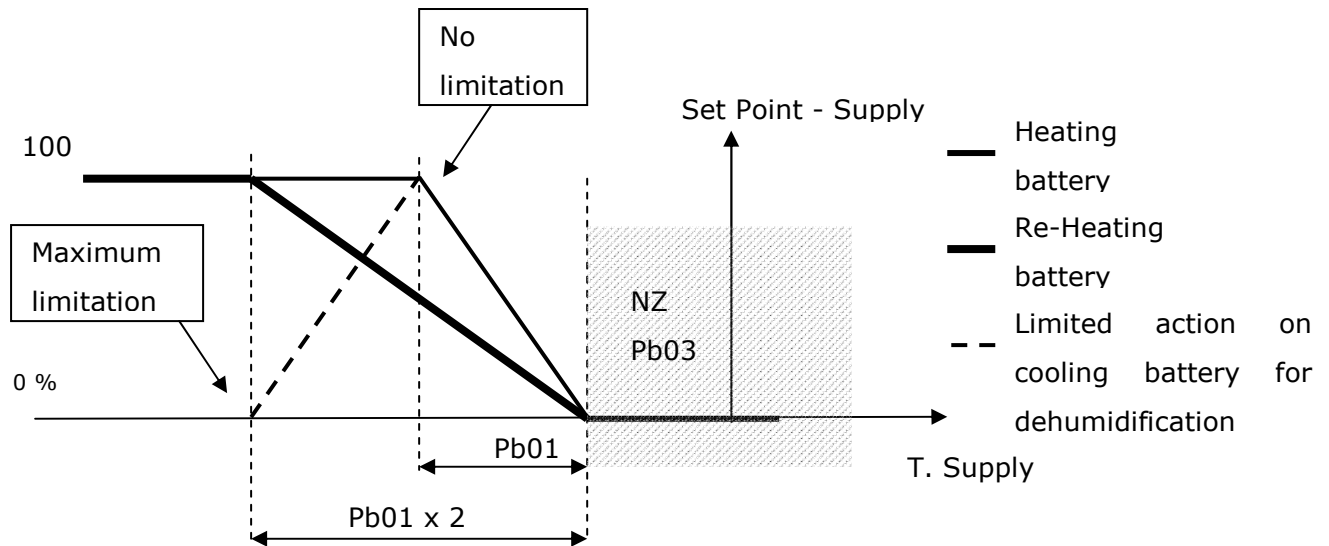

When the dehumidification request is active the action limit's objective will be to limit the dehumidification in order to prevent continuously cooling the air (caused by dehumidification) and, as a result, to always request more heat to the heating (and post-heating) coils. This action optimizes the control resulting also in energy savings.

Note: if the discharge air temperature sensor is in error this control cannot be utilized.

Example 1

Dehumidification request = 80%
 Dehumidification limitation = 50%

In this condition the request for dehumidification to the coils will be 40% which is 50% of the 80% of the effective request.

Example 2

Dehumidification request = 80%
 Dehumidification limitation = 25%

In this condition the request for dehumidification to the coils will be 20% which is 25% of the 80% of the effective request.

Example 3

Dehumidification request = 80%

Dehumidification limitation = 0%

In this condition the request for dehumidification will pass entirely to the coil.

The request of dehumidification and of the cooling coil is regulated by parameter PB15. The priority of these requests is:

- *Pb15=0*: cooling request
- *Pb15=1*: dehumidification request
- *Pb15=2*: the largest request
- *Pb15=3*: the arithmetic mean of the two requests

6.14.3 Winter dehumidification

There is the feature dehumidification even when the machine is running so the winter. The dehumidification works like winter but summer dehumidification using dedicated parameters (PU17 - PU24). To dehumidify the air damper will be used, and, just in case this is not available, the fans.

6.15 Humidification

To adjust the comfort of the room it is necessary to also consider the humidity in the air and to regulate it based on a determined Set point desired percentage (*PU01*) and at a neutral zone (*PU02*). If the room humidity sensor is present it is possible to command the humidifier using On/Off switch or by using the module.

Humidity management is enabled by activating the parameter *PG06*>0, in the configuration menu. The room air humidity sensor is also activated (*PH41*=1), if the sensor is disabled or in error dehumidification management will be inhibited.

6.15.1 Enabling humidifier (flow temperature operation)

In order to function correctly the humidifier requires a minimum value for air temperature, for which it identifies a Set point (*PU11*) and relative hysteresis (*PU12*) on the flow temperature to enable/disable the humidifier. This function is enabled by parameter *PU10*. In case *PU10*=0 (function disabled) the humidifier will Start-up/shutdown on the normal Set point percentage (*PU01*).

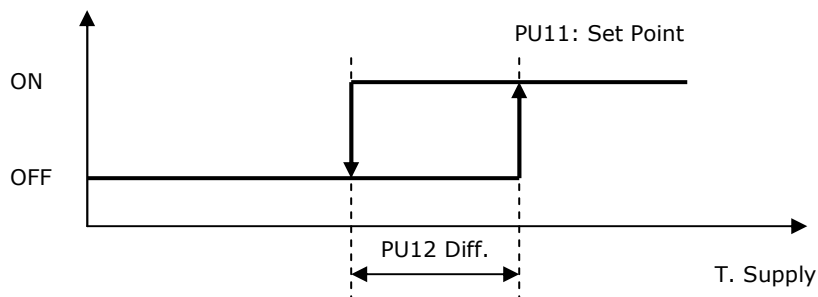

With the flow sensor in error the function is inhibited and the humidifier will Start-up/shutdown on the Set point percentage.

6.15.2 Humidifier On/Off

In order to utilize the On/Off control of the humidifier you must set parameter *PG06* to 1.

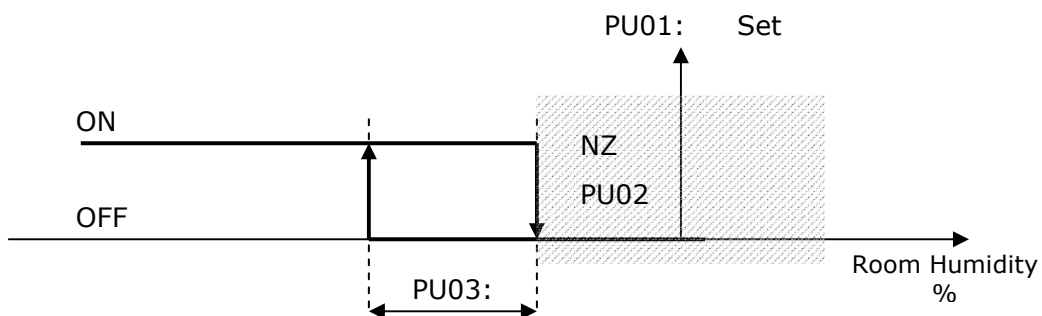

Note: in order to utilize this function it is necessary to enable the room humidity sensor, setting parameter *PH41* to 1. When the sensor is in error the humidifier is shut off.

6.15.3 Step of modulating humidifier with On / Off

To use the modulating humidifier to associate an analog output (*parameters HC*). E 'can also be configured to be used as a digital output relay enabling the humidifier.

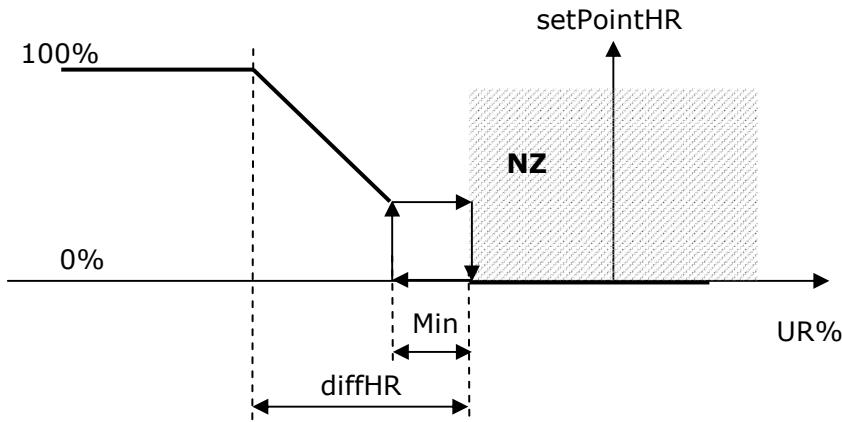

In opening the output remains at 0% as long as the request does not become greater than the parameter PU16, then takes the value of the request. In closing, the output takes the value of the request until it is greater than PU16, then is maintained at a value of up to PU16 that the request does not go to 0%.

6.15.4 Maximum humidification control

A maximum humidity sensor can be connected to the controller to prevent against excessive humidity in the flow duct. In case the discharge air humidity exceeds the maximum humidity set point (PU14), the humidification is switched off. In case the discharge air humidity becomes less than the maximum humidity set point – hysteresis maximum humidity (PU15), the humidifier is enabled again

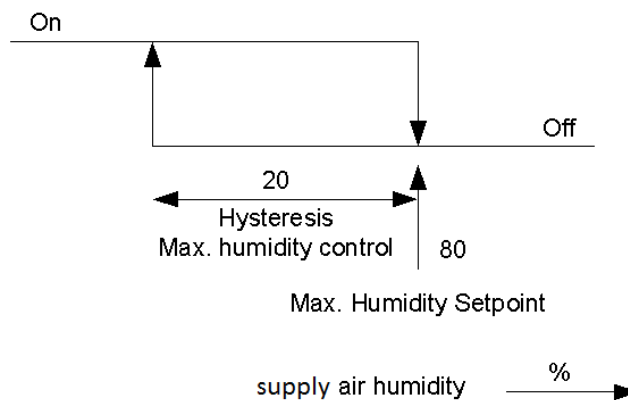

Note 1: to use this function it is necessary to enable the maximum setting parameter for discharging the air humidity control PU13 to 1.

Note 2: in order to utilize this function it is necessary to enable the discharge air humidity sensor, setting parameter PH47 to 1. When the sensor is in error the maximum humidification control is disabled.

6.15.5 Maximum humidity protection

A maximum humidity hygostat can be connected to the controller to prevent against excessive humidity in the flow duct. The humidification control is switched off when the hygostat indicates too high humidification.

6.15.6 Humidifier status

The humidifier assumes the following operating states:

1. *Disabled*: the humidifier has not been configured for the system. While in this status you will see the symbol "---" in the user interface.
2. *Off*: The humidifier is off. In the user interface you will see written "ON" when in this state "OFF".
3. *Off due to flow temperature*: humidifier is off due to the low discharge air temperature. In the user interface you will see written "ON" when in this status "Off".
4. *On*: humidifier is on. In the user interface you will see written "ON" when in this status "ON".
5. *Alarm*: humidifier is in alarm. In the user interface you will see written "ALARM" when in this status.

6.16 Dampers

The program provides the management of a motorized shutter for the intake of outdoor air to support the room temperature control. The type of management is determined by parameter *PG07*, in the configuration menu.

- *PG07=0*: Disabled
- *PG07=1*: Enabled in modulating control
- *PG07=2*: Enabled in fixed opening

Damper can be command by 2 DO of opening and closing, or by an AO (parameter *PS04*)

Note: on the configuration *PG00=5* and *PG00=6* is not possible to connect the dampers on the analogue outputs. For the other configurations, can be connected on any of the available analogue outputs.

6.16.1 Damper modulating regulation

In modulating control, the shutter can be utilized for:

- Free-Cooling / Free-Heating in temperature (parameter *PS01=1*)
- Air quality control (parameter *PS 02=1*)

The control also provides a position of minimal opening of the shutter to guarantee the minimal quantity of projected renewed air (parameter *PS05*) and the corresponding maximum position of the opening (parameter *PS06*).

6.16.2 Control in fixed opening

In this mode the outdoor air dampers always assumes the same value of opening as decided by parameter *PS10*. In this control the range of values of opening is from 0% to 100%, there is no minimum value for the opening. In order to utilize this control it is necessary to set *PG07=2*.

Note: with this modality the free-cooling, free-heating and the air quality control cannot be utilized.

6.16.3 Enabling Free-Cooling / Free-Heating in temperature

The free-cooling in temperature, if enabled ($PS01=1$), can be activated when the difference between the room air temperature and the outdoor air temperature reaches the Set point which has been set (parameter $PS13$) and relative hysteresis (parameter $PS12$).

The free-heating in temperature, if enabled ($PS01=1$), can be activated when the difference between the room air temperature and the outdoor air temperature reaches the Set point which has been set (parameter $PS13$) and relative hysteresis (parameter $PS12$).

Enable Free-Cooling in temperature

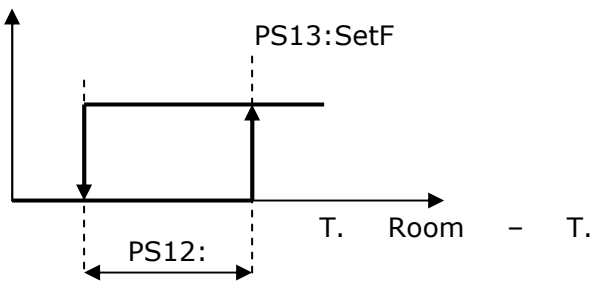

Enable Free-Heating in temperature

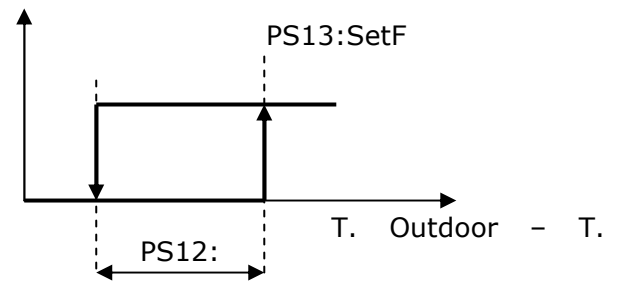

Note: it is necessary to enable the utilization of the outdoor air temperature sensor ($PH40=1$). If the sensor is in error the control is disabled.

6.16.4 Free-Cooling and Free-Heating Control

The control of the free-cooling/free-heating commands the opening of the outdoor air shutter.

When free-cooling/free-heating conditions exist; or if the control can be enabled (and the request is greater than zero) the ramps which command the heating/cooling are split into two successive ramps, the first (half the differential) regulates the free-cooling/free-heating using the outdoor air shutter, the second regulates the heating/cooling valves.

SUMMER operation/COOLING: Free-Cooling

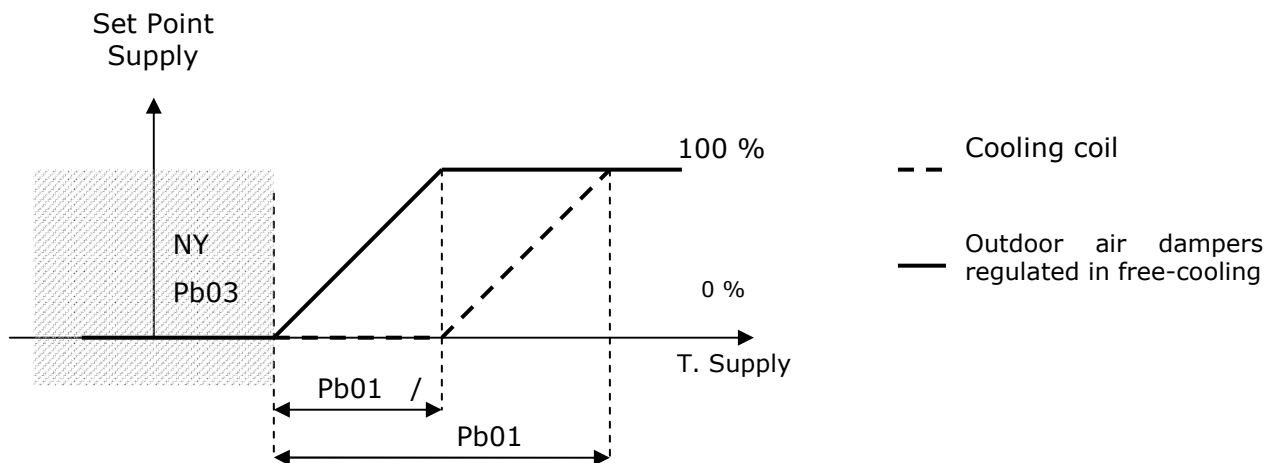

WINTER operation/HEATING: Free-Heating

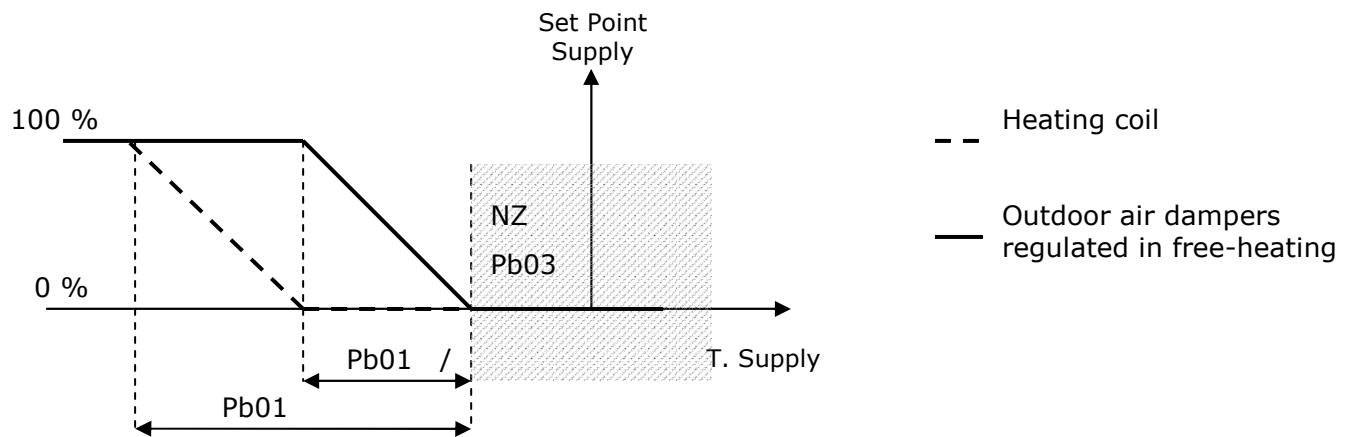

Note: if one of the sensors included in the control is in error the control of the free-cooling/free-heating can no longer be utilized and the heating/cooling ramp regulate the total control differential.

6.16.5 Air quality control

The outdoor damper may be used to replace the air upon request by the appropriate sensor (VOC/CO₂). It is necessary to enable the parameter $PS02=1$, and the control sensor for the air quality ($PH46>0$). The outdoor dampers can be commanded based on the control sensor at set point ($PS20$) and at the relative differential ($PS21$).

Note: If the air quality sensor is in error the control is inhibited. The sensor can be one of three types: 4..20mA ($PH46=1$), 0..5V ($PH46=2$) or 0..10V ($PH46=3$);

Note: the air quality sensor is always connected on the AI3 remote.

6.16.6 Damper command

The outdoor damper can be utilized for two controls: free-cooling/free-heating and air quality control.

The priority of these requests is decided by parameter $PS03$:

- $PS03=0$: The shutter is commanded by Free-cooling / Free-heating
- $PS03=1$: The shutter is commanded by air quality control
- $PS03=2$: The shutter is commanded by the largest request
- $PS03=3$: The damper request is calculated as the arithmetic mean of the two free-cooling (/free-heating) and air quality control requests. In a way to satisfy both active requests.

In order to correctly command the external shutter motor it is necessary to set the following parameters:

- $PS05$. Minimum position of dampers.
- $PS06$. Maximum position of dampers.
- $PS07$. Damper run time to go from 0% to 100%.
- $PS08$. Maximum time to maintain signal at end of relay.
- $PS09$ (optional). If greater than zero the command at relay are given only when the actual variation on the control ramp exceeds the set value. If $PS09=0$ the command will always pass.
- $PS15$ The minimum opening of damper can be deactivated ($PS15=0$), limited only if regulation is active ($PS15=1$), or always active ($PS15=2$).

Note: each time the unit is in ON status (for turning on the card, for restoration of an alarm block, or to restore the feed after a black-out), the dampers will re-align; for the entire run time (plus eventual time *PS09*), the shutter will close and the control will be interrupted.

Once the run time has elapsed the control will return to its normal operating state. This is necessary because there is no feedback for controlling the position of the shutter.

6.16.7 Damper status

In the user interface you can identify the operating status of the shutters which will present you with one of the following:

1. *Disabled:* the shutter is not managed by the controller. In the user interface you will see the symbol " - ". when in this state.
2. *Closed:* the shutter is closed. In the user interface you will see written "CLOSED" and a value of 0.0%. when in this status.
3. *Opening:* the shutter is in the process of opening. In the user interface you will see written "OPENING" flashing with the corresponding value when in this state.
4. *Open:* the shutter is open and still at the determined value. In the user interface you will see written "OPEN" and the corresponding value of opening when in this state.
5. *Closing:* the shutter is in the process of closing. In the user interface you will see written "CLOSING" flashing with the corresponding value when in this state.
6. *Alignment:* the shutter is in the process of moving in order to align in response to the start-up of the unit or because the tension is restoring. In the user interface you will see written "ALIGNMENT." with the value 0.0% flashing.

6.17 Heat recovery devices

When the quantity of renewed air is substantive the air treatment centres provide a system which recovers the exhaust air for a better exercise of energy costs.

Using the parameter (*PG13>0*) it is possible to utilize the heat recovery by selecting one of the following different heat recovery devices:

- *PG13 = 0:* Management disabled
- *PG13 = 1:* Heat recovery devices at cross flow
- *PG13 = 2:* Heat recovery devices with double coil
- *PG13 = 3:* Heat recovery device rotating On/Off
- *PG13 = 4:* Heat recovery device rotating modulating

Recovery management presupposes that the exhaust air temperature sensor is present, therefore in order to utilize the recovery the sensor will need to be enabled by setting parameter *PH42=1*.

6.17.1 Heat recovery devices at cross flow

In order to utilize this recovery device it is necessary to set $PG13=1$. The heat recovery devices provides a by-pass shutter which is used to prevent the passage of outdoor air through the air exchange channels.

The heat recovery device is normally always active and is by-passed during the free-cooling/free-heating phases or during the defrost cycles with external temperatures that are too low. Set the set point ($Pr03$) and the relative differential ($Pr04$) in order to activate the defrost cycle.

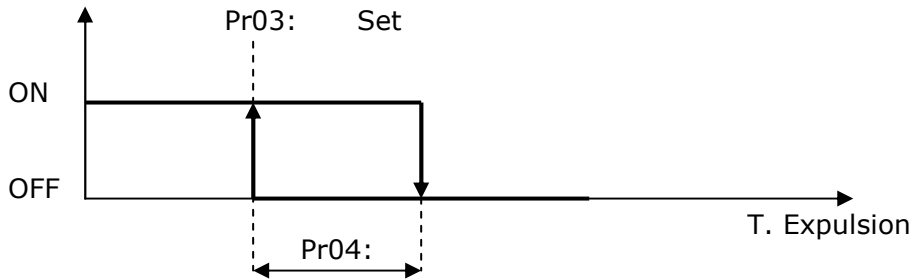

When the minimum temperature conditions of the exhaust air are reached, as represented in the diagram, a cyclical sequence of heat recovery device by-pass are activated in order to permit the exhaust air (hot, room air) to defrost the air exchange channels.

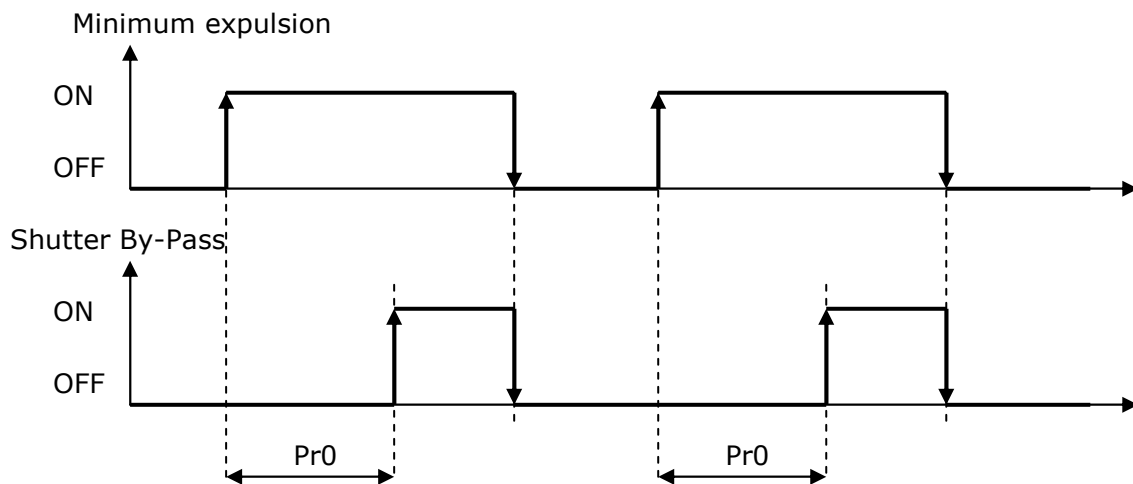

After the delay $Pr05$ the by-pass shutter will activate in order to allow for defrosting. When the temperature rises above the allowable value the shutter will deactivate while the heat recovery device restarts.

Note: when the control sensors are in error the function is disabled.

6.17.2 Heat recovery devices with double coil

In order to utilize this recovery device it is necessary to set $PG13=2$. The recovery device with double coil is activated via the exchange fluid pump between the two coils. In order to limit the pumps energy consumption, the activation will be managed by the difference between the exhaust air temperature and outdoor air temperature (parameter $Pr01$ and relative differential $Pr02$). The circulation pump will stop during the free-cooling and free-heating phases.

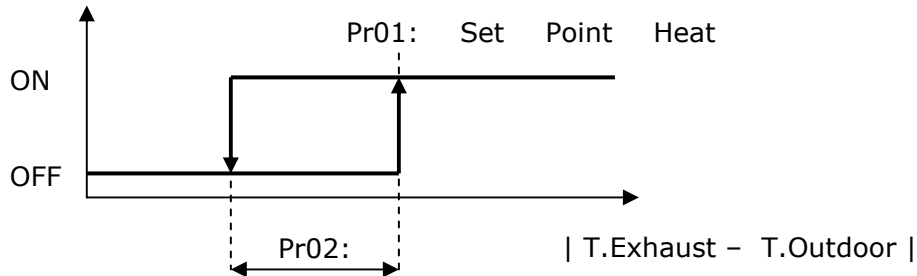

This heat recovery device does not require its minimum exhaust temperature to be controlled since frost will not accumulate inside the coil.

Note: the outdoor air temperature sensor must also be enabled ($PH40=1$). When the control sensors are in error the function is disabled.

6.17.3 Rotating heat recovery device

In this case the heat recovery device can be controlled in two different ways: On/Off ($PG13=3$), or with an analogue output ($PG13=4$) and is only active when the fans are turned on.

The heat recovery device will be deactivated during the free-cooling and free-heating phases.

PG13=3. Control On/Off

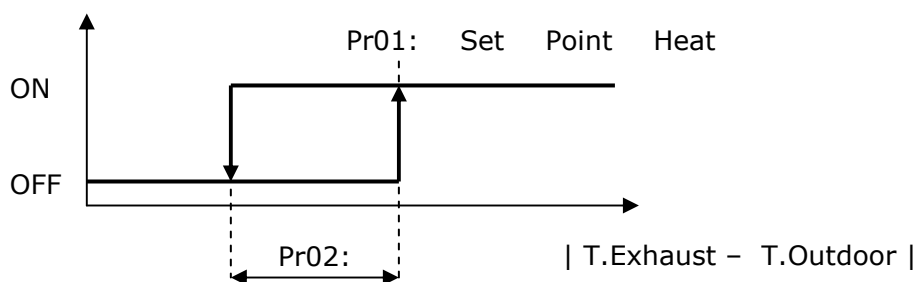

Note: the outdoor air temperature sensor must also be enabled ($PH40=1$). When the control sensors are in error the function is disabled.

PG13=4. Modulating control

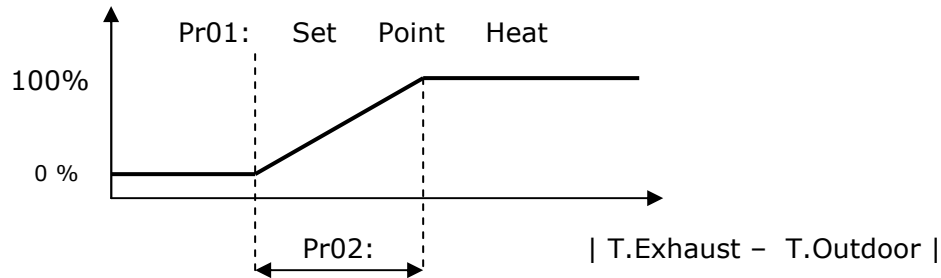

Note: the outdoor air temperature sensor must also be enabled ($PH40=1$). When the control sensors are in error the function is disabled.

6.17.4 Recovery device status

The heat recovery device may assume one of the following modes of operation:

1. *Disabled:* the recuperation is not being managed. In this status in the user interface you will see the symbol "...".
2. *Off:* the heat recovery device is off. In the user interface you will see written "ON" when in this state "OFF".
3. *In defrosting mode:* the heat recovery devices is off and defrosting is activated (only when heat recovery device is at cross flow, $PG13=1$). In this state in the user interface you will see written (and flashing) "OFF_D".
4. *Off for free-cooling/heating:* the heat recovery device is off (because of a request for free-cooling/heating). In this status in the user interface you will see written "OFF_F".
5. *On:* heat recovery device is on. In the user interface you will see written "ON" when in this state "ON".

6.18 Heating/cooling pumps

A simple method for managing the two circulation pumps (for heating/cooling) is provided. In order to enable the cooling pump you need to set parameter $PG10$ to 1. To enable the heating pump you will need to set parameter $PG11$ to 1 in the Configuration menu.

Based on the requirement you may choose between two controls by going to parameter $PP01$ (continuous control, On/Off control).

6.18.1 Continuous control

The continuous control is dependent on the status of the central unit. The pumps will Start-up and shutdown each time the machine starts up and shuts down. In order to set this control select $PP01=0$.

6.18.2 Control On/Off

The circulation pumps will activate when there is an actual heating/cooling request which exceeds a Start-up set ($PP02$) and they shutdown when the same request falls below a certain shutdown set ($PP03$). In order to set this control select $PP01=1$.

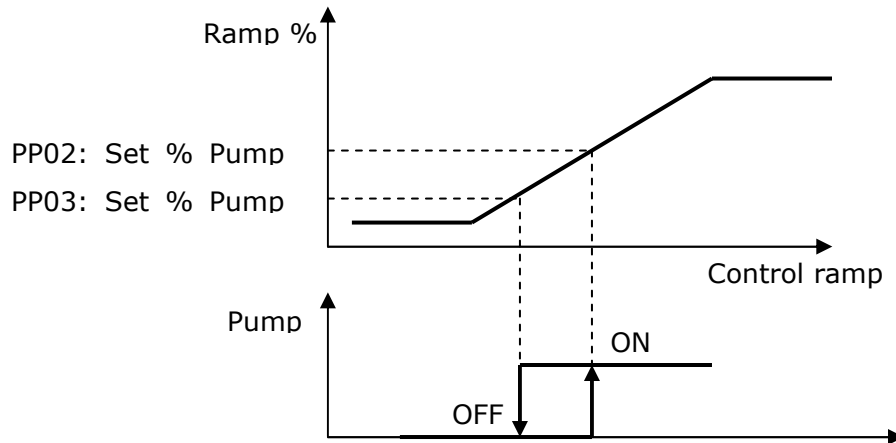

When the control ramp exceeds *PP02* the pump will activate; when it falls below *PP03* a timer will activate keeping the pump active for a set period of time (parameter *PP04*). The timer resets if the ramp returns above *PP02*. The pump will be shut down by using the shutdown command from the unit cancelling the active timer.

Note: in case where the primary control is on the fans (*PG04=0*), this control can be used only if the fan control is in the modulating type.

6.18.3 Pump status

Both pumps may assume any of the following operating states:

7. *Disabled*: the pump is not managed by the controller. In the user interface you will see the symbol " - " when in this state.
8. *Off*: the pump is off. In the user interface you will see written "ON" when in this state "OFF".
9. *Waiting for shutdown*: the pump is in the process of shutting down, and is in queue for scheduled protection. In this status in the user interface you will see written (and flashing) "WOFF".
10. *On*: the pump is on. In the user interface you will see written "ON" when in this state.
11. *Alarm*: the pump alarms are on. In the user interface you will see written "ALARM" when in this state.

6.18.4 Pump alarm inputs

Thermal pump alarm management is provided for both configured pumps.

6.19 Unit with single heating-cooling coil (seasonal)

In this type of unit ($PG01=1$) there is only one dedicated valve for heating and cooling and, if enabled, there is a single circulation pump; the operating mode (parameter $MOdE$) determines which behaviour to utilize.

In the same way all the controls (fans, free-cooling/free-heating, controls of set-point, alarms, etc..) are distinguished based on the operating mode. The heating function is guaranteed when the parameter $MOdE=1$; meanwhile the cooling function is guaranteed when $MOdE=0$.

The correct software configuration is obtained considering all the resources (parameters and operating states) normally utilized for heating the machine when using more than one coil, which, in these particular centres, are considered mixed resources commanded univocally based on operating mode (summer/winter). The "mixed" hardware parameters to consider for the unit at single coil with circulation pump are the following:

$PG01=1$ (single coil)

$PG10$: enable circulation pump (heating)

For units using a single coil it is not possible to manage dehumidification and post-heating. The resources normally managed for cooling and post-heating are not piloted; it is therefore recommended to reset all the configuration parameters in order to avoid malfunctions.

6.19.1 Right coil steps status

In the right coil steps status it is possible to control the relative configuration.

6.19.2 Primary control

For these types of units it makes sense to also set the primary control parameter $PG04$; using the appropriate configuration parameter, $PG04$, it is possible to choose the organ on which the primary control will be made from the central unit: fans or valves.

- If $PG04 = 0$, the primary control is made on the fans which, at the appropriate time, will be controlled in different ways (parameter $PF01$). This type of configuration excludes utilization of the valve and therefore the controller does not provide any commands on the analogue/digital outputs for controlling the single heating/cooling valve.
- If $PG04=1$, the primary control is made on the valve. The intake of hot/cold air is modulated by the heating/cooling coil; meanwhile the fans are working to recirculate the air of the central unit. Fan control can be set with the appropriate parameter $PF01$.

In units with more than one coil the parameter $PG04$ does not condition any control.

6.20 Management (various)

6.20.1 Single or distinct set point

It is possible to manage a single control Set point for summer/winter, or to set two different ones. If the parameter *PH27 enables the single/distinct* Set point is set to 1 the Set point is singular (only one parameter), otherwise the Set point is distinct (two distinct parameters: *SEtH* and *SEtC*).

In the case of a unique Set point (*PH27= 1*) the parameter *SEtC* (summer Set point), is no longer valid and the **unique control Set point** becomes the **SEtH** which no longer assumes the value of a single winter set but instead that of a single control Set point for the summer/winter.

6.20.2 Compensation for set point

Only during summer operating mode (parameter *MOdE=0=Cool*), the cooling control requests a compensation for the control room temperature Set point to function with the external temperature (parameter *PC01* to enable the function). The function is important to avoid an excessive jump in thermal temperature between the external and internal room temperatures and ensures adequate comfort under mutual conditions. Furthermore, this allows for energy savings on the plant.

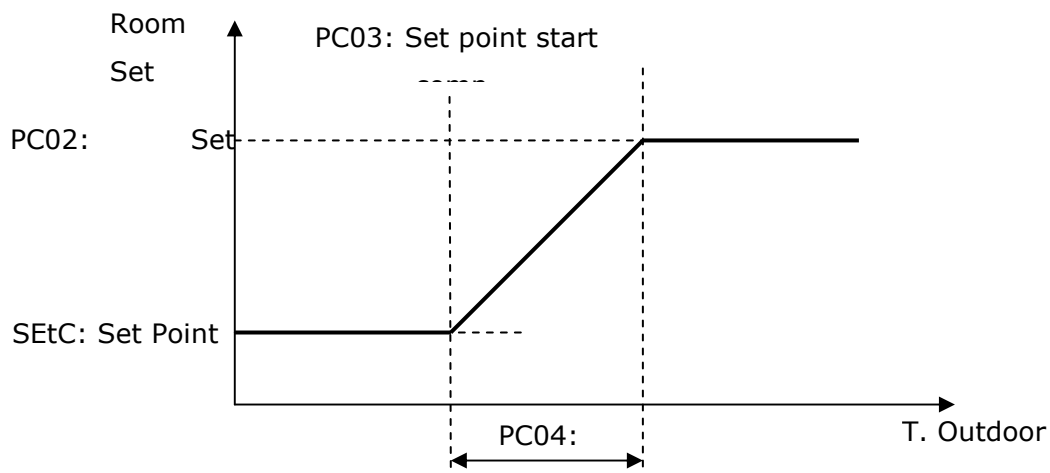

The compensation Set point increases proportionally with the increase in outdoor air temperature until it reaches the maximum admissible set configured at parameter *PC02*.

Note: in order to utilize this function it is necessary to enable the room humidity sensor, setting parameter *PH40* to 1. This function is inhibited with the external probe in error mode.

6.20.3 Variation set point from supervisor

The program provides the possibility to manage a parameter *OS02 Offset Set point from Supervisor* which, based on the status set by the supervisor, sums an offset at the control Set point. To enable this function set the parameter *PH26 Enable variation Set point from supervisor* and set to one the related variable from supervisor.

Note: the offset is summed at the current value of the Set point and not that which is defined by the parameter; this indicates that the Set point could have already been modified due to other interventions: time zone, variations by Digital inputs.

6.20.4 Manual fan operation

In this status the devices do not participate in thermo control; they are however sensitive to eventual alarms. Manual operation (or operating less than the two flow and return fans) is guaranteed by parameter *PM20*.

- If value set to 0 (*Auto*) this will define normal device behaviour
- If value set to 1 (*Manu*) this will disable the fans and bring them to manual operation

Fans operating manually do not participate in controls and can be forced into operation using parameter *PM21*.

If the fans are the On/Off type they may be forced on by simply setting any value greater than 0.0% at parameter *PM21*. If the fans are in modulating control, and therefore at inverter with parameter *PM21*, it is possible to set the speed which must be maintained during the test phase. In each case where the value is 0.0% the fans will remain off. While operating manually the fans will always be sensitive to alarms and related consequences. In order to restore at the control you will need to reset parameter *PM20* to the value "*Auto*" (Automatic).

6.21 Time schedule

The real time clock allows the operator to define a weekly schedule for the unit.

Three different time bands (T1/T2/T3) can be defined. Each time band have a set point offset to adjust the actual control set point.

Each day of the week can have 3 time bands, every band has an hour of start, and this band continue till next valid band of the same day, or other days.

If the RTC is in alarm or disabled, the function becomes inhibited.

6.22 Miscellaneous management

6.22.1 Last date of maintenance

In the *Menu Maintenance Operator->Operation* you will find a page with the ability to memorize the last date of maintenance for the plant. By pressing on "Update" the old date which is in the system will automatically be updated with the new correct date; updating the maintenance date can be done at parameter *PM90*.

6.22.2 Restore default parameters

Using the "Parameter resetting" procedure, all system parameters can be reset to their original default values. After entering the *InSt->MAP* menu – which is only accessible while the machine is switched **OFF** – set parameter *PH15=1* and wait for the "0" value to reappear on the display; the system will automatically reset all parameters back to their default values.

After this operation, it is necessary to power down the machine and then power it up again, to avoid the risk of malfunctions.

7 Diagnostics

The application is capable of managing a whole series of alarms, relating to fans, pumps, sensors and other operations from the central unit. Depending on the various alarm types, it is possible to configure their resetting (whether manual or automatic), a possible notification delay and any actions to be taken in that specific case.

When one or more alarms are active, the alarm icon flashes on displays.

In order to view the various alarms, the "Alarm" menu must be displayed from the main page, using the ESC key, followed by the ENTER key. By pressing the ESC key from an alarm page, or waiting for the 60-second timeout, the user is brought back to the application's main page.

To scroll the various active alarms, the ENTER key must be pressed once more: alarms are listed in order of priority, just as they are listed in the Alarm Table of chapter 7.2.

All digital inputs relating to alarms are managed by an *Alarm Logic* parameter, which takes on the following significance:

- If set to "NO", inputs will normally be de-energized (i.e. open): N.O. logic;
- If set to "NC", inputs will normally be energized (i.e. closed): N.C. logic.

7.1 Manual and automatic alarms

There are two types of alarms, those with manual reset and those with automatic reset. These alarms offer the end-user the choice of selecting, via the associated parameter, the resetting mode that better reflects the user's own requirements.

7.1.1 Manual-reset alarms

If an alarm with manual reset occurs:

- The alarm icon starts flashing.

By pressing the ENTER key from the "Alarm" menu, the code of the first active alarm is displayed.

Once the conditions which had triggered the alarm are back to normal, the alarm can be manually reset. To perform this operation:

- position on the page of the alarm to be restored
- Hold the ENTER key pressed down for about 2 seconds.

At this point, in the absence of any further alarms, the page showing "none" is displayed, the alarm icon is switched OFF, and the machine goes back to normal operation; otherwise, the code relating to the next active alarm will be displayed.

The consequences that derive from an active manual alarm remain valid until the user cancels the alarm message.

7.1.2 Automatic-reset alarms

If an alarm with automatic reset occurs:

- The alarm icon starts flashing.

By pressing the ENTER key from the "Alarm" menu, the code of the first active alarm is displayed.

Once the conditions that had triggered the alarm are back to normal, resetting and deletion of the alarm message automatically take place, without any need for user intervention.

The consequences deriving from an active auto-reset alarm remain valid as long as the causes that triggered the alarm are not reset.

7.2 Table of Alarms

The following is a list of all the alarms managed by the application. The order of presentation is the same as the order of presentation for the active alarms. All alarms can be viewed even when the machine is off.

Code	Description of the alarm	Rearm	Consequence	Delay
AL01	Thermal alarm fan (*2) Or alarm inverter (flow)	Auto	Shuts down all devices	Fixed 2 sec.
AL02	Thermal alarm fan (*2) Or alarm inverter (return)	Auto	Shuts down all devices	Fixed 2 sec.
AL03	Flow air flow switch (*2)	Manu	Shuts down all devices	Configurable
AL04	Return air flow switch (*2)	Manu	Shuts down all devices	Configurable
AL05	Thermal circulation heating pump	Auto	Stops the pump	Fixed 2 sec.
AL06	Thermal circulation cooling pump	Auto	Stops the pump	Fixed 2 sec.
AL07	Heating elements circuit breaker alarm (*2)	Auto	Shuts down all devices	Fixed 2 sec.
AL08	Air filter pressure switch	A/M	Display	Configurable
AL09	Humidifier	A/M	Stops the humidifier	Configurable
AL10	General alarm	A/M	Shuts down all devices	Configurable
AL11	Anti-freeze	Auto	Shuts down fans and closes the shutter Forces heating coil to 100% Forces cooling coil to 0%	Configurable
AL12	Heat recovery device alarm	Auto	Activates the heat recovery device by-pass	Configurable
AL13	Fire/smoke Alarm (*2)	Auto	Shuts down all devices	-
AL14	Operating hours - flow fans	Manu* ¹	Display	-
AL15	Operating hours - return fan	Manu* ¹	Display	-
AL16	Operating hours - coil 1 pump	Manu* ¹	Display	-
AL17	Operating hours - coil 2 pump	Manu* ¹	Display	-
AL18	Room temperature probe/return broken or disconnected	Auto	Inhibits the controls upon which the sensor is dependent	Configurable
AL19	Discharge air temperature sensor broken or disconnected	Auto	Inhibits the controls upon which the sensor is dependent	Configurable
AL20	Outdoor air temperature sensor broken or disconnected	Auto	Inhibits the controls upon which the sensor is dependent	Configurable
AL21	Room humidity probe/return broken or disconnected	Auto	Inhibits the controls upon which the sensor is dependent	Configurable
AL22	Exhaust air temperature sensor broken or disconnected	Auto	Inhibits the controls upon which the sensor is dependent	Configurable
AL23	Channel pressure probe broken or disconnected	Auto	Inhibits the controls upon which the sensor is dependent	Configurable
AL24	Air quality probe broken or disconnected	Auto	Inhibits the controls upon which the sensor is dependent	Configurable
AL25	Flow humidity sensor broken or disconnected	Auto	Inhibits the controls upon which the sensor is dependent	Configurable
AL26	Remote set point variator potentiometer broken or disconnected	Auto	Inhibits the controls upon which the sensor is dependent	Configurable
AL27	Dampers opening potentiometer broken	Auto	Inhibits the controls upon	Configurable

	or disconnected		which the sensor is dependent	
AL28	I/O configuration error	Auto	Shuts down all devices	-
AL29	RTC Alarm broken or discharged	A/M	Inhibits management of the time zone	-
AL30	External air damper end run	A/M	Shuts down all devices	Configurable

A/M: Automatic or Manual alarm (set from parameter)

(*1) To re-arm alarms connected to the hours of operation you need only reset the hours on the device to zero.

(*2) These alarms cause the unit to shutdown bringing it to the status OFF from alarm

7.2.1 Air flow switch alarm

The flow meter can be managed after the initial Start-up phase of the unit and after the *Flow meter delay from reset PA28*: once this time elapses, if the contact indicates lack of flow, the alarm will be raised immediately.

During normal operation the flow sensor is continuously monitored: if the contact indicates lack of flow for a period

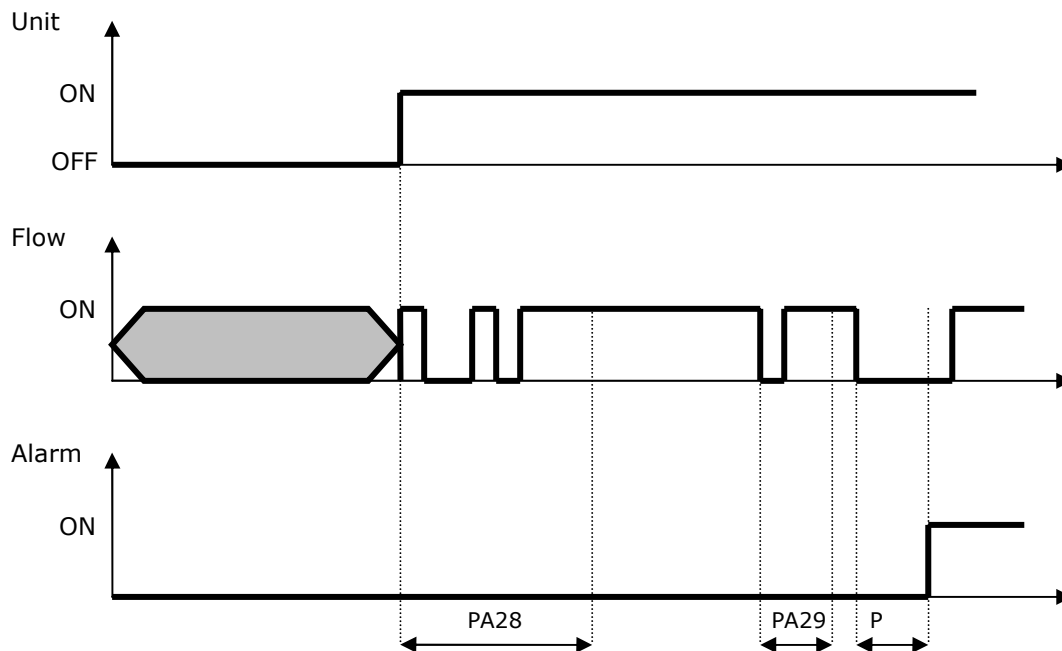

greater than that at parameter *PA29* the alarm will be raised immediately.

The flow meter alarm is restored manually; activation requires the shutdown of the unit bringing it to the state of *Alarm OFF*).

7.2.2 Anti-freeze alarm

The method used to enable the alarm is configurable with parameter *PA35*:

PA35=0: alarm disabled

PA35=1: alarm at digital input

7.3 Alarm relay

The program provides the possibility to manage a relay for a configurable alarm. For each type of alarm there is a parameter that permits you to choose whether that particular alarm must be signalled on the alarm relay. Additional alarms can be addressed at relay. Using the relative parameter (*PH60*) it is possible to define the polarity (NO, or NC) of the digital output of the alarm.

7.4 Alarms log

The controller stores in a non-volatile memory the alarm history.

In order to view the alarm history, choose *Show Alarm History* from the general Menu or from the main page by pressing ESC in order to view the following page:

```
Show ALARMS  >>
Show HISTORY  >>
```

You may press ENTER on *Show Alarm History*.

Each element of the history is associated with the following information:

- progressive number for the alarm
- mnemonic code of the alarm (AL01, AL03, ...)
- date and hours in which alarm has been acknowledged.

The code for every alarm is that which is presented in the alarm table. The storage capacity of the history is 100 events.

Using the parameter *PH18 Cancel Alarm History* it is possible to delete all the elements stored in the history; set the parameter to (YES) (1) and wait a couple of seconds until the re-reading of the default value NO (0).

Note 1. In the case where the memory capacity has reached its full limit (i.e. 100 events recorded) **and** you wish to record another event, the first event initially stored in memory will be overwritten with the new event. The same would follow for other elements.

Note 2. The history is enabled only if the parameter *PG03=1*, system clock is enabled.

8 Ethernet services configuration

All the settings about network parameters must be done with the network cable disconnected; alternatively, once the setting has been done the Personal Computer must be restarted.

The procedure to gain access to the configuration menu is the following:

- press  and  (LEFT/ENTER) for 4 s
- from the frame "Network Status" press  (DOWN) to scroll until node 1
- press  (ENTER).

8.1 Web Server

The Web Server functionality is active as default feature.

The basic configuration about the network can be done via user interface gaining access to the manufacturer menu and then to the Ethernet menu.

There are three parameters to set the address, subnet mask and gateway.

PE01: parameter device network address

PE02: parameter subnet mask

PE03: parameter gateway network address.

As standard setting the web server is configured to communicate on port 80 (standard http).

To modify the port it is necessary to gain access to the configuration menu and then to the menu Networks > (password -19) > Ethernet.

Scroll the items until:

- "Web Server Port" and type the desired value.

8.1.1 WEB interface

The WEB interface is made by a series of TAB dividing the quantities by groups.

To modify a quantity click on the value, modify and then change the focus (using TAB or positioning the cursor over another field).

The modification can be done on condition that the writing password has been typed.

8.1.2 Password for the parameters modification via WEB

The password for writing the parameters via WEB is the following:

Evco@AHU

To type the password click on the area in the top left corner.

A text box will appear.

To unlock the writing of parameters send the password again.

Anyway, after 5 minutes the password will be cancelled and to modify the parameters again it must be typed again.

8.2 MQTT

As default, the MQTT functionality is disabled.

To enable it it is necessary to gain access to the menu Networks > (password -19) > Ethernet.

Scroll the items until "Enable MQTT".

Set 1 to enable sending the data to the defined Broker.

Scroll the voices until "MQTT broker IP", then configure the desired broker IP.

As default the value is

176.58.125.240

This is the address of the EVCO server.

Scroll the voices until "MQTT port".

This is the communication port with the broker. The default value is 1883.

Scroll the items until "MQTT time zone".

This value is the time zone of the Country the device is installed.

The default is 1 (+1 h) which is the value for Italy.

Scroll the items until "MQTT time zone".

This is the setting for the daylight saving time:

- 1 the running date is daylight saving time
- 0 the running date is not daylight saving time.

8.3 ModBus TCP/IP

The MODBUS TCP/IP service exports all the variables there are in the project list.

As standard setting, the access is on port 502 (standard setting for MODBUS use via TCP/IP).

It is possible to modify the port using the menu Networks > (password -19) > Ethernet.

Scroll the items until "Port MB Slave" and type the desired value.

9 List of Modbus® variables

This section will be updated with the actual list of Modbus variables.

9.1 c-pro 3 NODE kilo AHU

Addr Base 0	Addr Base 1	Name	Value	Min	Max	Mode	BMS
0x0000	1	PMXX_enabDemo	0	0	1	R/W	
0x0001	2	PMXX_TEnvironment_DEMO	21.8	-15.0	70.0	R/W	
0x0002	3	PMXX_Tsupply_DEMO	24.6	-15.0	70.0	R/W	
0x0003	4	PMXX_TOutdoor_DEMO	7.3	-15.0	70.0	R/W	
0x0004	5	PMXX_HreturnRoom_DEMO	43	0	100	R/W	
0x0005	6	PMXX_AirExhaust_DEMO	21.3	-15.0	70.0	R/W	
0x0006	7	PMXX_Pressure_DEMO	6.4	0.0	145.0	R/W	
0x0007	8	PMXX_AirQuality_DEMO	500	0	2000	R/W	
0x0008	9	PMXX_Hsupply_DEMO	43	0	100	R/W	
0x0009	10	PMXX_remoteDamper_DEMO	-327.64	-327.68	100.00	R/W	
0x000A	11	PMXX_remoteSet_DEMO	0.0	-10.0	10.0	R/W	
0x0100	257	Packed_DI	0	0	65535	R/W	
0x0101	258	Packed_logicDI1	0	0	65535	R/W	
0x0102	259	Packed_logicDI2	0	0	65535	R/W	
0x0103	260	Packed_logicDI3	0	0	65535	R/W	
0x0180	385	Packed_DO1	0	0	65535	R/W	
0x0181	386	Packed_DO2	0	0	65535	R/W	
0x0182	387	Packed_DO3	0	0	65535	R/W	
0x0200	513	AI_Toutdoor	0.0	-3276.8	3276.7	R/O	
0x0201	514	AI_TreturnRoom	0.0	-3276.8	3276.7	R/O	
0x0202	515	AI_Tsupply	0.0	-3276.8	3276.7	R/O	
0x0203	516	AI_HretRoom	0	-32768	32767	R/O	
0x0204	517	AI_TExhaust	0.0	-3276.8	3276.7	R/O	
0x0205	518	AI_Hsupply	0	-32768	32767	R/O	
0x0206	519	AI_Pressure	0.0	-3276.8	3276.7	R/O	
0x0207	520	AI_AQ	0	-32768	32767	R/O	
0x0208	521	AI_remoteDamper	0	-32768	32767	R/O	
0x0209	522	AI_remoteSet	0	-32768	32767	R/O	
0x0281	642	out_Vmix_Coil1	0.00	0.00	100.00	R/W	
0x0282	643	out_Vmix_Coil2	0.00	0.00	100.00	R/W	
0x0283	644	out_SupplyFan	0.00	0.00	100.00	R/W	
0x0284	645	out_ReturnFan	0.00	0.00	100.00	R/W	
0x0285	646	out_Heater	0.00	0.00	100.00	R/W	

0x0286	647	out_Humidifier	0.00	0.00	100.00	R/W	
0x0287	648	out_MixDamper	0.00	0.00	100.00	R/W	
0x0288	649	out_Recover	0.00	0.00	100.00	R/W	
0x0300	769	PackedAlarm_1	0	0	65535	R/W	
0x0301	770	PackedAlarm_2	0	0	65535	R/W	
0x0400	1025	Status_OnOff_bySUP	0	0	1	R/W	
0x0401	1026	Status_MoDe_bySUP	0	0	1	R/W	
0x0402	1027	Status_En_OffsetSP_bySUP	0	0	1	R/W	
0x0500	1281	CLOCK_RTC (Low)	-	01/01/2000	19/01/2068 03:14:07	R/W	
0x0501	1282	CLOCK_RTC (High)					
0x0502	1283	statusUnit	0	0	255	R/W	
0x0503	1284	v_MoDe	1	0	1	R/W	
0x0504	1285	Active_SetPoint_Environment	0.0	-15.0	158.0	R/W	
0x0505	1286	actual_SupplySetPoint	0.0	-15.0	158.0	R/W	
0x0506	1287	actual_SupplySetPoint_Heating	0.0	-15.0	158.0	R/W	
0x0507	1288	actual_SupplySetPoint_Cooling	0.0	-15.0	158.0	R/W	
0x0508	1289	actualSPhum	0	-32768	32767	R/W	
0x0509	1290	actualSPdeHhum	0	-32768	32767	R/W	
0x050A	1291	Status_SupplyFan	0	0	6	R/W	
0x050B	1292	Status_ReturnFan	0	0	6	R/W	
0x050C	1293	Status_Pump1	0	0	4	R/W	
0x050D	1294	Status_Pump2	0	0	4	R/W	
0x050E	1295	Status_Humidifier	0	0	4	R/W	
0x050F	1296	Status_Recover	0	0	4	R/W	
0x0510	1297	statusHeater1	0	0	5	R/W	
0x0511	1298	statusHeater2	0	0	5	R/W	
0x0512	1299	Status_extDamper	0	0	5	R/W	
0x0513	1300	Status_MixAirShutter	0	0	5	R/W	
0x0514	1301	Position_MixShutter	0.00	0.00	100.00	R/W	
0x0515	1302	UI_TBactual	0	0	255	R/W	
0x0516	1303	TBoffset	0.0	-3276.8	3276.7	R/W	
0x0517	1304	limitC	0.00	0.00	100.00	R/W	
0x0518	1305	limitH	0.00	0.00	100.00	R/W	
0x0519	1306	Request_AirQuality	0.00	0.00	100.00	R/W	
0x051A	1307	Req_FreeCoolingHeating	0.00	0.00	100.00	R/W	
0x051B	1308	DeHumid_ValveRequest	0.00	0.00	100.00	R/W	
0x0600	1537	F1_Monday_p1	0	0	4	R/W	
0x0601	1538	F1_Monday_h1 (Low)	00:00:00	00:00:00	23:59:59	R/W	
0x0602	1539	F1_Monday_h1 (High)					
0x0603	1540	F2_Monday_p2	0	0	4	R/W	

0x0604	1541	F2_Monday_h2 (Low)	00:00:00	00:00:00	23:59:59	R/W	
0x0605	1542	F2_Monday_h2 (High)					
0x0606	1543	F3_Monday_p3	0	0	4	R/W	
0x0607	1544	F3_Monday_h3 (Low)	00:00:00	00:00:00	23:59:59	R/W	
0x0608	1545	F3_Monday_h3 (High)					
0x0609	1546	F1_Tuesday_p1	0	0	4	R/W	
0x060A	1547	F1_Tuesday_h1 (Low)	00:00:00	00:00:00	23:59:59	R/W	
0x060B	1548	F1_Tuesday_h1 (High)					
0x060C	1549	F2_Tuesday_p2	0	0	4	R/W	
0x060D	1550	F2_Tuesday_h2 (Low)	00:00:00	00:00:00	23:59:59	R/W	
0x060E	1551	F2_Tuesday_h2 (High)					
0x060F	1552	F3_Tuesday_p3	0	0	4	R/W	
0x0610	1553	F3_Tuesday_h3 (Low)	00:00:00	00:00:00	23:59:59	R/W	
0x0611	1554	F3_Tuesday_h3 (High)					
0x0612	1555	F1_Wednesday_p1	0	0	4	R/W	
0x0613	1556	F1_Wednesday_h1 (Low)	00:00:00	00:00:00	23:59:59	R/W	
0x0614	1557	F1_Wednesday_h1 (High)					
0x0615	1558	F2_Wednesday_p2	0	0	4	R/W	
0x0616	1559	F2_Wednesday_h2 (Low)	00:00:00	00:00:00	23:59:59	R/W	
0x0617	1560	F2_Wednesday_h2 (High)					
0x0618	1561	F3_Wednesday_p3	0	0	4	R/W	
0x0619	1562	F3_Wednesday_h3 (Low)	00:00:00	00:00:00	23:59:59	R/W	
0x061A	1563	F3_Wednesday_h3 (High)					
0x061B	1564	F1_Thursday_p1	0	0	4	R/W	
0x061C	1565	F1_Thursday_h1 (Low)	00:00:00	00:00:00	23:59:59	R/W	
0x061D	1566	F1_Thursday_h1 (High)					
0x061E	1567	F2_Thursday_p2	0	0	4	R/W	
0x061F	1568	F2_Thursday_h2 (Low)	00:00:00	00:00:00	23:59:59	R/W	
0x0620	1569	F2_Thursday_h2 (High)					
0x0621	1570	F3_Thursday_p3	0	0	4	R/W	
0x0622	1571	F3_Thursday_h3 (Low)	00:00:00	00:00:00	23:59:59	R/W	
0x0623	1572	F3_Thursday_h3 (High)					
0x0624	1573	F1_Friday_p1	0	0	4	R/W	
0x0625	1574	F1_Friday_h1 (Low)	00:00:00	00:00:00	23:59:59	R/W	
0x0626	1575	F1_Friday_h1 (High)					
0x0627	1576	F2_Friday_p2	0	0	4	R/W	
0x0628	1577	F2_Friday_h2 (Low)	00:00:00	00:00:00	23:59:59	R/W	
0x0629	1578	F2_Friday_h2 (High)					
0x062A	1579	F3_Friday_p3	0	0	4	R/W	
0x062B	1580	F3_Friday_h3 (Low)	00:00:00	00:00:00	23:59:59	R/W	

0x062C	1581	F3_Friday_h3 (High)					
0x062D	1582	F1_Saturday_p1	0	0	4	R/W	
0x062E	1583	F1_Saturday_h1 (Low)	00:00:00	00:00:00	23:59:59	R/W	
0x062F	1584	F1_Saturday_h1 (High)					
0x0630	1585	F2_Saturday_p2	0	0	4	R/W	
0x0631	1586	F2_Saturday_h2 (Low)	00:00:00	00:00:00	23:59:59	R/W	
0x0632	1587	F2_Saturday_h2 (High)					
0x0633	1588	F3_Saturday_p3	0	0	4	R/W	
0x0634	1589	F3_Saturday_h3 (Low)	00:00:00	00:00:00	23:59:59	R/W	
0x0635	1590	F3_Saturday_h3 (High)					
0x0636	1591	F1_Sunday_p1	0	0	4	R/W	
0x0637	1592	F1_Sunday_h1 (Low)	00:00:00	00:00:00	23:59:59	R/W	
0x0638	1593	F1_Sunday_h1 (High)					
0x0639	1594	F2_Sunday_p2	0	0	4	R/W	
0x063A	1595	F2_Sunday_h2 (Low)	00:00:00	00:00:00	23:59:59	R/W	
0x063B	1596	F2_Sunday_h2 (High)					
0x063C	1597	F3_Sunday_p3	0	0	4	R/W	
0x063D	1598	F3_Sunday_h3 (Low)	00:00:00	00:00:00	23:59:59	R/W	
0x063E	1599	F3_Sunday_h3 (High)					
0x063F	1600	M0dE_OperatingMode	0	0	1	R/W	
0x0640	1601	SEtC_SummerSetPoint	24.0	-15.0	158.0	R/W	
0x0641	1602	SEtH_WinterSetPoint	20.0	-15.0	158.0	R/W	
0x0642	1603	PU01_Humidity_SetPoint	55	0	100	R/W	
0x0643	1604	OS02_OffsetSetPoint_SUP	0.0	-36.0	36.0	R/W	
0x0644	1605	OT01_OffsetSetPoint_T1	0.0	-36.0	36.0	R/W	
0x0645	1606	OT02_OffsetSetPoint_T2	0.0	-36.0	36.0	R/W	
0x0646	1607	OT03_OffsetSetPoint_T3	0.0	-36.0	36.0	R/W	
0x0647	1608	OH01_OffsetSetPoint_holiday	0.0	-36.0	36.0	R/W	
0x0648	1609	PM00_Limit_HourFan (Low)	20000	0	100000	R/W	
0x0649	1610	PM00_Limit_HourFan (High)					
0x064A	1611	PM01_SupplyFan_Hours (Low)	0	0	100000	R/W	
0x064B	1612	PM01_SupplyFan_Hours (High)					
0x064C	1613	PM02_ReturnFan_Hours (Low)	0	0	100000	R/W	
0x064D	1614	PM02_ReturnFan_Hours (High)					
0x064E	1615	PM10_Limit_HourPump (Low)	20000	0	100000	R/W	
0x064F	1616	PM10_Limit_HourPump (High)					
0x0650	1617	PM11_PumpHeatHours (Low)	0	0	100000	R/W	
0x0651	1618	PM11_PumpHeatHours (High)					
0x0652	1619	PM12_PumpCoolHours (Low)	0	0	100000	R/W	
0x0653	1620	PM12_PumpCoolHours (High)					

0x0654	1621	PM90_LastMaintainDATE (Low)	01/01/2008 00:00:01	01/01/2008 00:00:01	19/01/2068 03:14:07	R/W	
0x0655	1622	PM90_LastMaintainDATE (High)					
0x0656	1623	OE01_OffsetSetPoint_economy	0.0	-36.0	36.0	R/W	
0x0658	1625	PM88_Calibration_remoteSet	0.0	-10.0	10.0	R/W	
0x0659	1626	PM89_Calibration_remoteDamper	0.00	-10.00	10.00	R/W	
0x065A	1627	PM80_Calibration_OutdoorProbe	0.0	-18.0	18.0	R/W	
0x065B	1628	PM81_Calibration_ReturnRoomProbe	0.0	-18.0	18.0	R/W	
0x065C	1629	PM82_Calibration_TsupplyProbe	0.0	-18.0	18.0	R/W	
0x065D	1630	PM83_Calibration_HreturnRoom_Probe	0	-10	10	R/W	
0x065E	1631	PM84_Calibration_AirExhaustProbe	0.0	-18.0	18.0	R/W	
0x065F	1632	PM85_Calibration_Pressure	0.0	-145.0	145.0	R/W	
0x0660	1633	PM86_Calibration_AirQuality_Probe	0	-100	100	R/W	
0x0661	1634	PM87_Calibration_Hsupply	0	-10	10	R/W	
0x0662	1635	PC01_EnableSetPointCompensation	0	0	1	R/W	
0x0663	1636	PC02_MaxSetPoint_Compensation	28.0	-15.0	158.0	R/W	
0x0664	1637	PC03_SetPointExternal_StartCompensation	26.0	-15.0	158.0	R/W	
0x0665	1638	PC04_OffsetSetPointExternal_Compensation	4.0	0.0	36.0	R/W	
0x0666	1639	PC05_Enable_SniffingMode	0	0	1	R/W	
0x0667	1640	PC06_WaitTime_SniffingCycle	6	1	99	R/W	
0x0668	1641	PC07_ActiveTime_SniffingCycle	2	1	30	R/W	
0x0669	1642	PC08_EnableBothFans_onSniffing	1	0	1	R/W	
0x066A	1643	PC61_summerCommutationSP	20.0	-20.0	158.0	R/W	
0x066B	1644	PC62_winterCommutationSP	10.0	-20.0	158.0	R/W	
0x066C	1645	PC63_TempChangeover	2	0	2	R/W	
0x066D	1646	PF01_FanRegulationType	7	0	7	R/W	
0x066E	1647	PF02_FanRegulation_Diff	5.0	0.0	54.0	R/W	
0x066F	1648	PF03_MinSpeedFan	40.00	0.00	100.00	R/W	
0x0670	1649	PF04_MaxSpeedFan	100.00	0.00	100.00	R/W	
0x0671	1650	PF05_Fan_TonOther	5	0	999	R/W	
0x0673	1652	PF08_FanRegulation_InverterOnOff_Diff	0.00	0.00	60.00	R/W	
0x0674	1653	PF09_FanRegulation_InverterOnOff_Time	10	0	999	R/W	
0x0675	1654	PF10_ForceOnErrorProbe	30.00	0.00	100.00	R/W	
0x0676	1655	PF11_StaticPressSetPointRamp	1.0	0.0	145.0	R/W	
0x0677	1656	PF12_StaticPressSetPoint	3.0	0.0	145.0	R/W	
0x0678	1657	PF13_StaticPressPropBand	0.5	0.0	72.5	R/W	
0x0679	1658	PF14_StaticPressIntegralTime	0	0	300	R/W	
0x067A	1659	PF15_EnableFanLimitation	0	0	1	R/W	
0x067B	1660	PF16_MinTempLimitFan	10.0	-15.0	158.0	R/W	
0x067C	1661	PF17_MaxTempLimitFan	40.0	-15.0	158.0	R/W	
0x067D	1662	PF18_FanLimitation_Diff	5.0	0.0	54.0	R/W	

0x067E	1663	Pb01_Temperature_Diff_Valve	10.0	0.0	36.0	R/W	
0x067F	1664	Pb02_Valve_Ti	0	0	999	R/W	
0x0680	1665	Pb03_NeutralZone_Temperature	4.0	0.0	36.0	R/W	
0x0681	1666	Pb05_Offset_ValveSupplySetPoint	0.0	0.0	36.0	R/W	
0x0682	1667	Pb06_Diff_ValveSupplySetPoint	5.0	0.0	36.0	R/W	
0x0683	1668	Pb10_ForceHeatValve_OnErrorProbe	30.00	0.00	100.00	R/W	
0x0684	1669	Pb11_ForceCoolValve_OnErrorProbe	30.00	0.00	100.00	R/W	
0x0685	1670	Pb15_PriorityCoolingReq	0	0	3	R/W	
0x0686	1671	Pb20_ResistorOnOffDelayTime	60	0	999	R/W	
0x0687	1672	PU02_NeutralZone_Humidity	6	0	100	R/W	
0x0688	1673	PU03_Humidity_Diff	10	0	100	R/W	
0x0689	1674	PU04_ValveDeHumidification_Ti	0	0	999	R/W	
0x068A	1675	PU05_EnLimitDeHumid	0	0	1	R/W	
0x068B	1676	PU10_tSupply_EnableHumidifier	1	0	1	R/W	
0x068C	1677	PU11_tSupply_EnableHumidifier_Set	22.0	-15.0	158.0	R/W	
0x068D	1678	PU12_tSupply_EnableHumidifier_Diff	3.0	0.0	68.0	R/W	
0x068E	1679	PU13_hSupply_EnableHumidifier	1	0	1	R/W	
0x068F	1680	PU14_hSupply_EnableHumidifier_Set1	80	0	95	R/W	
0x0690	1681	PU15_hSupply_EnableHumidifier_Diff1	20	0	40	R/W	
0x0691	1682	PS01_Type_FreeCoolingHeating	0	0	1	R/W	
0x0693	1684	PS03_Type_ControlShutter	0	0	4	R/W	
0x0695	1686	PS05_MinRegulationValue_AirExternalShutter	20.00	0.00	100.00	R/W	
0x0696	1687	PS06_MaxRegulationValue_AirExternalShutter	100.00	0.00	100.00	R/W	
0x0697	1688	PS07_PreStartTime_extDamper	45	0	65535	R/W	
0x0698	1689	PS08_DelayOFF_extDamper	15	0	65535	R/W	
0x0699	1690	PS09_FineCorsa_WaitTime	30	0	999	R/W	
0x069A	1691	PS10_FixRegulationValue_AirExternalShutter	50.00	0.00	100.00	R/W	
0x069B	1692	PS12_FreeCoolingHeatingTemp_enDiff	2.0	0.0	36.0	R/W	
0x069C	1693	PS13_FreeCoolingHeatingTemp_enSetPoint	4.0	0.0	68.0	R/W	
0x069D	1694	PS15_EnableMinVal_AirExternalShutter	0	0	2	R/W	
0x069E	1695	PS20_AirQuality_SetPoint	600	0	10000	R/W	
0x069F	1696	PS21_AirQuality_Diff	100	0	2000	R/W	
0x06A0	1697	Pr01_SetPointDiff_HeatRecover	5.0	0.0	36.0	R/W	
0x06A1	1698	Pr02_Diff_HeatRecover	3.0	0.0	36.0	R/W	
0x06A2	1699	Pr03_SetPoint_MinTemp_HeatRecover	1.0	-15.0	158.0	R/W	
0x06A3	1700	Pr04_Diff_MinTemp_HeatRecover	4.0	0.0	36.0	R/W	
0x06A4	1701	Pr05_TimeByPass_Recover	5	1	99	R/W	
0x06A5	1702	Pr07_MinVal_RecoverAO	0.00	0.00	100.00	R/W	
0x06A6	1703	Pr08_MaxVal_RecoverAO	100.00	0.00	100.00	R/W	
0x06A7	1704	PP01_PumpRegulation	0	0	1	R/W	

0x06A8	1705	PP02_SetON_Pump	5.00	1.00	90.00	R/W	
0x06A9	1706	PP03_SetOFF_Pump	2.00	1.00	90.00	R/W	
0x06AA	1707	PP04_TimeOFF_Pump	10	1	99	R/W	
0x06AB	1708	PA01_En_Alarm_HourFan	1	0	1	R/W	
0x06AC	1709	PA02_En_Alarm_HourPump	0	0	1	R/W	
0x06AD	1710	PA03_signalHoursAlarmOnRelay	1	0	1	R/W	
0x06AE	1711	PA04_AlarmProbe_Delay	10	0	240	R/W	
0x06AF	1712	PA05_signalSensorsAlarmOnRelay	1	0	1	R/W	
0x06B1	1714	PA09_signalFanAlarmOnRelay	1	0	1	R/W	
0x06B2	1715	PA16_signalThermalPumpAlarmOnRelay	1	0	1	R/W	
0x06B3	1716	PA20_ResetType_AlarmDirtyRecoverSwitch	1	0	1	R/W	
0x06B4	1717	PA21_AlarmDirtyRecoverSwitch	30	0	999	R/W	
0x06B5	1718	PA24_ResetType_AlarmAirFilterSwitch	1	0	1	R/W	
0x06B6	1719	PA25_AlarmAirFilterSwitchDelay	2	0	999	R/W	
0x06B7	1720	PA26_signalPressSwitchAlarmOnRelay	1	0	1	R/W	
0x06B8	1721	PA28_AlarmAirFlowSwitchDelay_Reset	30	0	999	R/W	
0x06B9	1722	PA29_AlarmAirFlowSwitchDelay	5	0	999	R/W	
0x06BA	1723	PA30_signalAirFlowAlarmOnRelay	1	0	1	R/W	
0x06BB	1724	PA31_ResetType_AlarmHumidifier	0	0	1	R/W	
0x06BC	1725	PA32_HumidifierAlarm_Delay	2	0	999	R/W	
0x06BD	1726	PA33_signalHumidHygroAlarmOnRelay	1	0	1	R/W	
0x06BF	1728	PA36_AlarmAntiFreeze_Delay	5	0	999	R/W	
0x06C0	1729	PA37_signalAntiFreezeAlarmOnRelay	1	0	1	R/W	
0x06C1	1730	PA40_EnableAlarmRTC	1	0	1	R/W	
0x06C2	1731	PA41_ResetType_AlarmRTC	1	0	1	R/W	
0x06C3	1732	PA42_signalRTCAlarmOnRelay	1	0	1	R/W	
0x06C4	1733	PA45_signalFireSmokeAlarmOnRelay	1	0	1	R/W	
0x06C5	1734	PH01_MinValPressure	0.0	-145.0	652.5	R/W	
0x06C6	1735	PH02_MaxValPressure	30.0	-145.0	652.5	R/W	
0x06C7	1736	PH03_MinValueSetPointTemperature	-5.0	-15.0	158.0	R/W	
0x06C8	1737	PH04_MaxValueSetPointTemperature	40.0	-15.0	158.0	R/W	
0x06C9	1738	PH05_Enable_OnOffByKey	1	0	1	R/W	
0x06CA	1739	PH06_EnableChangeMode_KEY	1	0	1	R/W	
0x06CB	1740	PH07_EnableChangeMode_byDI	0	0	1	R/W	
0x06CC	1741	PH08_EnableChangeMode_CHOVER	0	0	1	R/W	
0x06CD	1742	PH09_Enable_OnOffBySuperv	0	0	1	R/W	
0x06CE	1743	PH10_EnableChangeMode_SUP	0	0	1	R/W	
0x06CF	1744	PH11_Modbus_Address	1	1	247	R/W	
0x06D0	1745	PH12_Modbus_Baud	3	0	7	R/W	
0x06D1	1746	PH13_Modbus_Parity	2	0	2	R/W	

0x06D2	1747	PH14_Modbus_StopBit	0	0	1	R/W	
0x06D3	1748	PH15_RestoreDefault	0	0	1	R/W	
0x06D4	1749	PH18_HistoryReset	0	0	1	R/W	
0x06D5	1750	PH20_Enable_Scheduler	0	0	1	R/W	
0x06D6	1751	PH21_Enable_TB_holiday	0	0	1	R/W	
0x06D8	1753	PH26_EnableOffsetSP_SUP	0	0	1	R/W	
0x06D9	1754	PH27_EnableUniqueSetPoint	0	0	1	R/W	
0x06DA	1755	PH32_TemperatureUM	0	0	1	R/W	
0x06DB	1756	PH33_PressureUM	0	0	1	R/W	
0x06DC	1757	PH34_Language	0	0	1	R/W	
0x06DD	1758	PH37_MinPPM_QualityAir	0	0	10000	R/W	
0x06DE	1759	PH38_MaxPPM_QualityAir	2000	0	10000	R/W	
0x06E5	1766	PH50_Logic_DI_OnOff_Remote	0	0	1	R/W	
0x06E6	1767	PH51_Logic_suppRetFanDI_Alarm	0	0	1	R/W	
0x06E7	1768	PH52_Logic_DI_AlarmAirflow	0	0	1	R/W	
0x06E8	1769	PH53_Logic_DI_AlarmFire	1	0	1	R/W	
0x06E9	1770	PH54_Logic_pumpCoil1_DI_Alarm	0	0	1	R/W	
0x06EA	1771	PH55_Logic_pumpCoil2_DI_Alarm	0	0	1	R/W	
0x06EB	1772	PH19_Enable_OnOffByScheduler	0	0	1	R/W	
0x06EC	1773	PH56_Logic_Humid_DI_Alarm	0	0	1	R/W	
0x06ED	1774	PH57_Logic_Antifreeze_DI_Alarm	0	0	1	R/W	
0x06EE	1775	PH58_Logic_AirFilter_DI_Alarm	0	0	1	R/W	
0x06EF	1776	PH59_Logic_exchangerSwitch_DI	0	0	1	R/W	
0x06F0	1777	PH60_Logic_DI_Heaters	0	0	1	R/W	
0x06F1	1778	PH61_Logic_DIeconomy	0	0	1	R/W	
0x06F2	1779	PH62_Logic_DIsumWin	0	0	1	R/W	
0x06F3	1780	PH63_Logic_DIgeneralAL	0	0	1	R/W	
0x06F4	1781	PH64_Logic_DIdefrost	0	0	1	R/W	
0x06F5	1782	PH65_Logic_DIIDamper	0	0	1	R/W	
0x06F6	1783	PG00_UnitType	0	0	46	R/W	
0x06F7	1784	PG01_Recover	0	0	1	R/W	
0x06F8	1785	PG02_FanSteps	0	0	3	R/W	
0x06F9	1786	PG03_Coil1Type	0	0	3	R/W	
0x06FA	1787	PG04_Coil1Mode	0	0	3	R/W	
0x06FB	1788	PG05_Coil2Type	0	0	2	R/W	
0x06FC	1789	PG06_ResistorsType	0	0	3	R/W	
0x06FD	1790	PG07_DXsteps	0	0	2	R/W	
0x06FE	1791	PG12_EnDeHumidification	1	0	1	R/W	
0x06FF	1792	PG13_HeatingRecover_Type	1	0	4	R/W	
0x0700	1793	PG14_RegProbe_Return	0	0	1	R/W	

0x0701	1794	PH80_Select_TypeAO_coil1	3	1	3	R/W	
0x0702	1795	PH81_Select_TypeAO_coil2	3	1	3	R/W	
0x0703	1796	PH82_Select_TypeAO_SupplyFan	3	0	4	R/W	
0x0704	1797	PH83_Select_TypeAO_ReturnFan	3	0	4	R/W	
0x0705	1798	PH84_Select_TypeAO_MixDamper	3	1	3	R/W	
0x0706	1799	PH85_Select_TypeAO_Humidifier	3	1	3	R/W	
0x0707	1800	PH86_Select_TypeAO_Heater	3	1	3	R/W	
0x0708	1801	PH87_Select_TypeAO_RotRecover	3	1	3	R/W	
0x070C	1805	startHoliday (Low)	01/01/2000	01/01/2000	19/01/2068 03:14:07	R/W	
0x070D	1806	startHoliday (High)					
0x070E	1807	endHoliday (Low)	01/01/2000	01/01/2000	19/01/2068 03:14:07	R/W	
0x070F	1808	endHoliday (High)					
0x0710	1809	PSd1_UserPassword	0	-999	9999	R/W	
0x0711	1810	PSd2_MaintainPassword	0	-999	9999	R/W	
0x0712	1811	PSd3_InstallerPassword	0	-999	9999	R/W	
0x0715	1814	PM22_forceFan	0	0	3	R/W	
0x0716	1815	PB21_secondZone	12.0	0.0	36.0	R/W	
0x0717	1816	PB22_secondDiff	3.0	0.0	18.0	R/W	
0x0718	1817	PU06_RelativeHumControlSensor	0	0	1	R/W	
0x0719	1818	Pb30_EnableSupplyLimitation	3	0	3	R/W	
0x071A	1819	Pb31_TlimitCooling	10.0	-15.0	158.0	R/W	
0x071B	1820	Pb32_TlimitDiff	5.0	0.0	54.0	R/W	
0x071C	1821	Pb33_MinValLimitationC	0.0	0.0	100.0	R/W	
0x071D	1822	Pb34_TlimitHeating	30.0	-15.0	158.0	R/W	
0x071E	1823	Pb35_TlimitDiff	5.0	0.0	54.0	R/W	
0x071F	1824	Pb36_MinValLimitationH	0.0	0.0	100.0	R/W	
0x0720	1825	PF19_SetCO2_min	500	0	10000	R/W	
0x0721	1826	PF20_SetCO2_max	1100	0	10000	R/W	
0x0722	1827	PF21_ValFirstStepMod	33.00	0.00	100.00	R/W	
0x0723	1828	PF22_ValSecondStepMod	66.00	0.00	100.00	R/W	
0x0724	1829	PF23_ValThirdStepMod	100.00	0.00	100.00	R/W	
0x0725	1830	PF24_MinTimeOnStepsFan	2	0	999	R/W	
0x0726	1831	PF25_MinTimeOnFan	60	0	999	R/W	
0x0727	1832	PF26_EnablePostFan	1	0	1	R/W	
0x0728	1833	PF27_MinTimePostFan	30	0	999	R/W	
0x0729	1834	PF28_DeltaPercReturnFan	0.00	-100.00	100.00	R/W	
0x072A	1835	PF29_DeltaStepReturnFan	0	-2	2	R/W	
0x072B	1836	PA22_ResetType_generalAL	1	0	1	R/W	
0x072C	1837	PA23_generalAL	30	0	999	R/W	
0x072D	1838	PA34_ResetType_AlarmThermalResistor	0	0	1	R/W	

0x072E	1839	PA35_ThermalResistorAlarm_Delay	2	0	999	R/W	
0x072F	1840	PH40_Tret_sensor	1	0	4	R/W	
0x0730	1841	PH41_Tsup_sensor	1	0	4	R/W	
0x0731	1842	PH42_Text_sensor	1	0	4	R/W	
0x0732	1843	PH43_HreturnRoom_sensor	3	0	3	R/W	
0x0733	1844	PH44_Texhaust	1	0	4	R/W	
0x0734	1845	PH45_Pressure_sensor	3	0	3	R/W	
0x0735	1846	PH46_AQ_sensor	3	0	3	R/W	
0x0736	1847	PH47_Hsupply_sensor	3	0	3	R/W	
0x0737	1848	PH48_remoteSet_sensor	3	0	3	R/W	
0x0738	1849	PH49_remoteDamper_sensor	3	0	3	R/W	
0x0739	1850	PH70_Logic_DO_fan	0	0	1	R/W	
0x073A	1851	PH71_Logic_DO_extDamper	0	0	1	R/W	
0x073B	1852	PH72_Logic_DO_byPassRecover	0	0	1	R/W	
0x073C	1853	PH73_Logic_DO_humidifier	0	0	1	R/W	
0x073D	1854	PH74_Logic_DO_heater	0	0	1	R/W	
0x073E	1855	PH75_Logic_DO_ONOFFmc	0	0	1	R/W	
0x073F	1856	PH76_Logic_DO_coilDX	0	0	1	R/W	
0x0740	1857	PH77_Logic_DO_alarm	0	0	1	R/W	
0x0741	1858	PH78_Logic_DO_sumWin	0	0	1	R/W	
0x0742	1859	PH79_Logic_DO_pump	0	0	1	R/W	
0x0743	1860	PH90_MinValSetRemote	-5.0	-18.0	18.0	R/W	
0x0744	1861	PH91_MaxValSetRemote	5.0	-18.0	18.0	R/W	
0x0745	1862	HA00	0	0	2	R/W	
0x0746	1863	HA01	0	0	28	R/W	
0x0747	1864	HA02	0	0	28	R/W	
0x0748	1865	HA03	0	0	28	R/W	
0x0749	1866	HA04	0	0	22	R/W	
0x074A	1867	HA05	0	0	22	R/W	
0x074B	1868	HA06	0	0	22	R/W	
0x074C	1869	HA07	0	0	28	R/W	
0x074D	1870	HA08	0	0	28	R/W	
0x074E	1871	HA09	0	0	28	R/W	
0x074F	1872	HB01[0]	0	0	18	R/W	
0x0750	1873	HB01[1]	0	0	18	R/W	
0x0751	1874	HB01[2]	0	0	18	R/W	
0x0752	1875	HB01[3]	0	0	18	R/W	
0x0753	1876	HB01[4]	0	0	18	R/W	
0x0754	1877	HB01[5]	0	0	18	R/W	
0x0755	1878	HB01[6]	0	0	18	R/W	

0x0756	1879	HB01[7]	0	0	18	R/W	
0x0757	1880	HB01[8]	0	0	18	R/W	
0x0758	1881	HC01[0]	0	0	8	R/W	
0x0759	1882	HC01[1]	0	0	8	R/W	
0x075A	1883	HC01[2]	0	0	8	R/W	
0x075B	1884	HC01[3]	0	0	8	R/W	
0x075C	1885	HC01[4]	0	0	8	R/W	
0x075D	1886	HC01[5]	0	0	8	R/W	
0x075E	1887	HCF1	10	10	2000	R/W	
0x075F	1888	HCF2	10	10	2000	R/W	
0x0760	1889	HD01[0]	0	0	18	R/W	
0x0761	1890	HD01[1]	0	0	18	R/W	
0x0762	1891	HD01[2]	0	0	18	R/W	
0x0763	1892	HD01[3]	0	0	18	R/W	
0x0764	1893	HD01[4]	0	0	18	R/W	
0x0765	1894	HD01[5]	0	0	18	R/W	
0x0766	1895	HD01[6]	0	0	18	R/W	
0x0767	1896	HD01[7]	0	0	18	R/W	
0x0768	1897	HD01[8]	0	0	18	R/W	
0x0769	1898	PB23_mezzastagioneZone	4.0	0.0	36.0	R/W	
0x076A	1899	PB24_mezzastagioneDiff	10.0	0.0	18.0	R/W	
0x076B	1900	Pb25_MinimumCoilRampThreshold	0.00	0.00	100.00	R/W	
0x076C	1901	Pu16_MinimumHumidityRampThreshold	0.00	0.00	100.00	R/W	
0x076D	1902	PU17_EnFreeDeHumidification	1	0	1	R/W	
0x076E	1903	PU18_FreeHumidity_SetPoint	55	0	100	R/W	
0x076F	1904	PU19_NeutralZone_FreeHumidity	6	0	100	R/W	
0x0770	1905	PU20_FreeHumidity_Diff	10	0	100	R/W	
0x0771	1906	PU21_ValveFreeDeHumidification_Ti	0	0	999	R/W	
0x0772	1907	PU22_FreeDeHumLim_Set	50.00	0.00	100.00	R/W	
0x0773	1908	PU23_FreeDeHumLim_Diff	20.00	0.00	100.00	R/W	
0x0774	1909	PU24_FreeDehumidType	1	0	3	R/W	
0x0775	1910	HA10	0	0	28	R/W	
0x0776	1911	HB01[9]	0	0	18	R/W	
0x0777	1912	HB01[10]	0	0	18	R/W	
0x0778	1913	HB01[11]	0	0	18	R/W	
0x0779	1914	HB01[12]	0	0	18	R/W	
0x077A	1915	HD01[9]	0	0	20	R/W	
0x077B	1916	HD01[10]	0	0	20	R/W	
0x077E	1919	PH92_SimbolMode	0	0	1	R/W	
0x077F	1920	PE01_Eth_IP_Address (IP1.IP2)	192.168.0.2	0.0.0.0	255.255.255.255	R/W	

0x0780	1921	PE01_Eth_IP_Address (IP3.IP4)				R/W	
0x0781	1922	PE02_Eth_SubnetMask (IP1.IP2)	255.255.255.0	0.0.0.0	255.255.255.255	R/W	
0x0782	1923	PE02_Eth_SubnetMask (IP3.IP4)				R/W	
0x0783	1924	PE03_Eth_Gateway (IP1.IP2)	192.168.0.1	0.0.0.0	255.255.255.255	R/W	
0x0784	1925	PE03_Eth_Gateway (IP3.IP4)				R/W	

c-pro 3 NODE kilo AHU

Application manual ver. 1.0

PT - 47/14

Code 144CP3NKAHE114

This document is exclusive property of EVCO. Reproduction and disclosure are prohibited without express authorisation from EVCO.

EVCO is not liable for any features, technical data and possible errors stated in this document or deriving from use of the same.

EVCO cannot be considered liable for damage caused by failure to comply with warnings given in this document.

EVCO reserves the right to make any changes without forewarning, without jeopardising the basic safety and operating features.



EVCO S.p.A.

Via Feltre 81, 32036 Sedico Belluno ITALIA

Tel. 0437 / 84.22

Fax 0437 / 83.648

info@evco.it

www.evco.it