

Applications

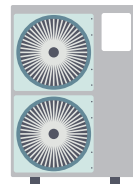

Heat pump

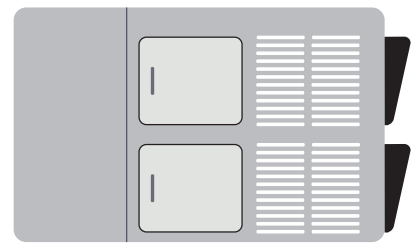

Air handling unit

EVJ LCD

Remote User Interfaces

- | Static LCD display
- | 6 capacitive touch keys
- | INTRABUS or RS-485 communication port
- | Built-in alarm buzzer
- | Built-in temperature and humidity sensor
- | Built-in Bluetooth Low Energy sensor



USE

Device for indoor applications



IMPORTANT

Read this document thoroughly before installation and before use of the device and follow all recommendations; keep this document with the device for future consultation. Only use the device in the way described in this document; do not use the same as a safety device



CONSIDER THE ENVIRONMENT

Please read carefully and save this document



DISPOSAL

The device must be disposed of in compliance with local standards regarding the collection of electric and electronic equipment

Index

 Introduction	5
 Purchasing codes	6
12 VAC/DC models for panel or wall mounting	6
 Purchasing codes description	6
12 VAC/DC models for panel or wall mounting	6
 Purchasing codes	7
115... 230 VAC models for wall mounting	7
 Purchasing codes description	7
115... 230 VAC models for wall mounting	7
 Dimensions	8
12 VAC/DC models for panel mounting	8
12 VAC/DC models for wall mounting	8
115... 230 VAC models for wall mounting	8
 Installation	9
12 VAC/DC models for panel mounting	9
To be fitted to a panel with elastic holding flaps	9
12 VAC/DC models for wall mounting	9
A) Wall mounting	9
B) Flush mounting box	9
115... 230 VAC models for wall mounting	10
Mounted onto in-wall electrical box with rear housing of back power module	10
 Electrical connections	11
12 VAC/DC models for panel mounting	11
Connectors and parts	11
Electrical connection with independent power supply	12
Electrical connection with device powered by a controller	12
12 VAC/DC models for wall mounting	13
Connectors and parts	13
Electrical connection with independent power supply	14
Electrical connection with device powered by a controller	14
Termination of the RS-485 network	14
Electrical connection for models with RS-485 port	15
Connectors description	15
Micro-switch EVIF22ISX	15
115... 230 VAC models for wall mounting	16
Connectors and parts	16
Electrical connection with independent power supply	17

 User interface	18
Key description	18
Switching ON/OFF the device	18
Accessing the procedure	18
Accessing the menu	18
 Settings menu	19
Sensitive areas description and parameters settings	19
Keys	19
Parameters settings	19
 Technical data	22

Introduction

The remote user interfaces **EVJ LCD** can be used as remote displays for a wide range of EVCO controllers for HVAC applications and many programmable controllers in the **c-pro 3 range**.

Depending on the model, a number of different features are installed:

- 1 or 2 analogue/digital input
- 2 digital outputs
- 1 built-in temperature and humidity sensor
- 1 built-in Bluetooth BLE communication module

Equipped with INTRABUS proprietary port, they provide an effective and economical alternative for point-to-point applications.

With their clean modern lines, LCD display, function icons and 6 capacitive keys, these interfaces blend perfectly with any type of environment also given their panel and wall mounting and the option of their own or controller power feed. The version housed in a built-in box enables it to be powered directly from the mains (115...230 VAC) with no need for transformers.



Purchasing codes

12 VAC/DC models for panel or wall mounting

The following table shows the available EVJ LCD models and the relative purchasing codes

Features	12 VAC/DC models for panel or wall mounting					
	EVJD900N2	EVJD900N2VW	EVJD900N2VWTX	EVJD900N2VWIV	EVJD920N2VW	EVJD920N2VWIV
Power supply						
12 VAC/DC	•	•	•	•	•	•
Analog/digital input						
NTC/DI		1	1	1	1	1
User interface						
Static LCD display	•	•	•	•	•	•
Installation mode						
Panel mounting (black front)	•					
Wall mounting (white front)		•	•	•	•	•
Connections						
Removable screw terminal	•					
Fixed screw terminal blocks		•	•	•	•	•
Communication ports						
INTRABUS	1	1		1	1	1
RS-485 INTRABUS			1			
Other Features						
Alarm and signalling buzzer	•	•	•	•	•	•
Built-in temperature and humidity sensor					•	•
Built-in Bluetooth Low Energy sensor				•		•

For further informations look at chapter "Technical data"

Purchasing codes description

12 VAC/DC models for panel or wall mounting

Features	Codes
12 VAC/DC - Static LCD display - Panel mounting - INTRABUS - Alarm and signalling buzzer	EVJD900N2
12 VAC/DC - Static LCD display - Wall mounting - NTC/DI - INTRABUS - Alarm and signalling buzzer	EVJD900N2VW
12 VAC/DC - Static LCD display - Wall mounting - NTC/DI - RS-485 INTRABUS - Alarm and signalling buzzer	EVJD900N2VWTX
12 VAC/DC - Static LCD display - Wall mounting - NTC/DI - INTRABUS - Alarm and signalling buzzer - Built-in Bluetooth Low Energy sensor	EVJD900N2VWIV
12 VAC/DC - Static LCD display - Wall mounting - NTC/DI - INTRABUS - Alarm and signalling buzzer - Built-in temperature and humidity sensor	EVJD920N2VW
12 VAC/DC - Static LCD display - Wall mounting - NTC - NTC - INTRABUS - Alarm and signalling buzzer - Built-in Bluetooth Low Energy sensor - Built-in temperature and humidity sensor	EVJD920N2VWIV

Purchasing codes

115... 230 VAC models for wall mounting

The following table shows the available EVJ LCD models and the relative purchasing codes

Features	115... 230 VAC models for wall mounting			
	EVJD902N9VP	EVJD902N9VPIV	EVJD922N9VP	EVJD922N9VPIV
Power supply				
115... 230 VAC	•	•	•	•
Analog/digital inputs				
NTC/DI	2	2	2	2
Digital outputs (electromechanical relays)				
Relay 1	1 A	1 A	1 A	1 A
Relay 2	1 A	1 A	1 A	1 A
User interface				
Static LCD display	•	•	•	•
Installation mode				
Wall mounted (white front)	•	•	•	•
Connections				
Fixed screw terminal blocks	•	•	•	•
Communication ports				
INTRABUS	•	•	•	•
Other Features				
Alarm and signalling buzzer	•	•	•	•
Built-in temperature and humidity sensor			•	•
Built-in Bluetooth Low Energy sensor		•		•

For further informations look at chapter "Technical data"

Purchasing codes description

115... 230 VAC models for wall mounting

Features	Codes
115... 230 VAC - Static LCD display - Wall mounted - 2 NTC/DI - 2 relays - Alarm and signalling buzzer - INTRABUS	EVJD902N9VP
115... 230 VAC - Static LCD display - Wall mounted - 2 NTC/DI - 2 relays - Alarm and signalling buzzer - INTRABUS - Built-in Bluetooth Low Energy sensor	EVJD902N9VPIV
115... 230 VAC - Static LCD display - Wall mounted - 2 NTC/DI - 2 relays - Alarm and signalling buzzer - INTRABUS - Built-in temperature and humidity sensor	EVJD922N9VP
115... 230 VAC - Static LCD display - Wall mounted - 2 NTC/DI - 2 relays - Alarm and signalling buzzer - INTRABUS - Built-in Bluetooth Low Energy sensor - Built-in temperature and humidity sensor	EVJD922N9VPIV

Dimensions

12 VAC/DC models for panel mounting



WARNINGS

- The thickness of a metal panel must be between 0.8 and 1.5 mm ($\frac{1}{32}$ and $\frac{1}{16}$ in), while that for a plastic panel must be between 0.8 and 3.4 mm ($\frac{1}{32}$ and $\frac{1}{8}$ in)
- The measurements of drilling template must be 107.6 x 72.6 mm ($3\frac{15}{16}$ x $2\frac{7}{8}$ in), with rounded corners R 3.0 mm ($\frac{1}{8}$ in).

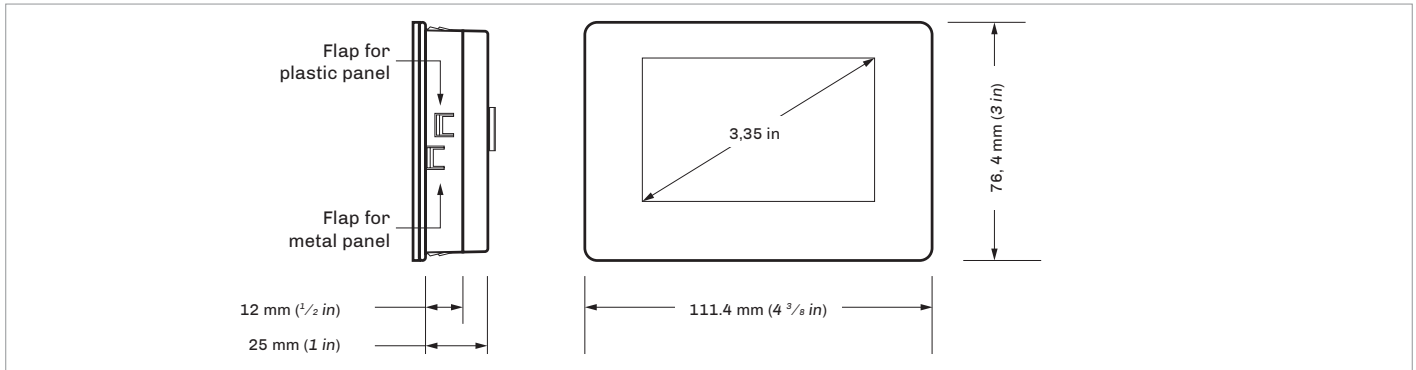

12 VAC/DC models for wall mounting

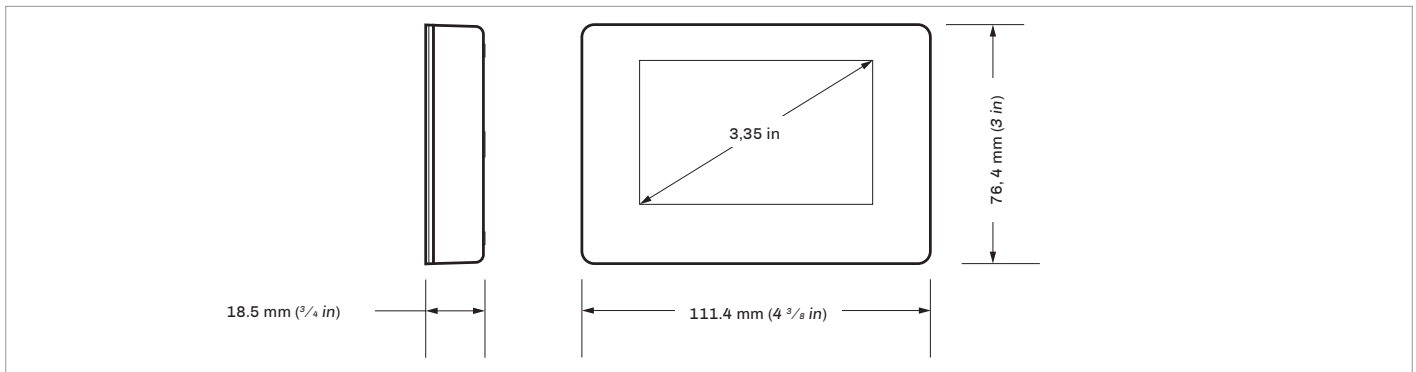

115... 230 VAC models for wall mounting

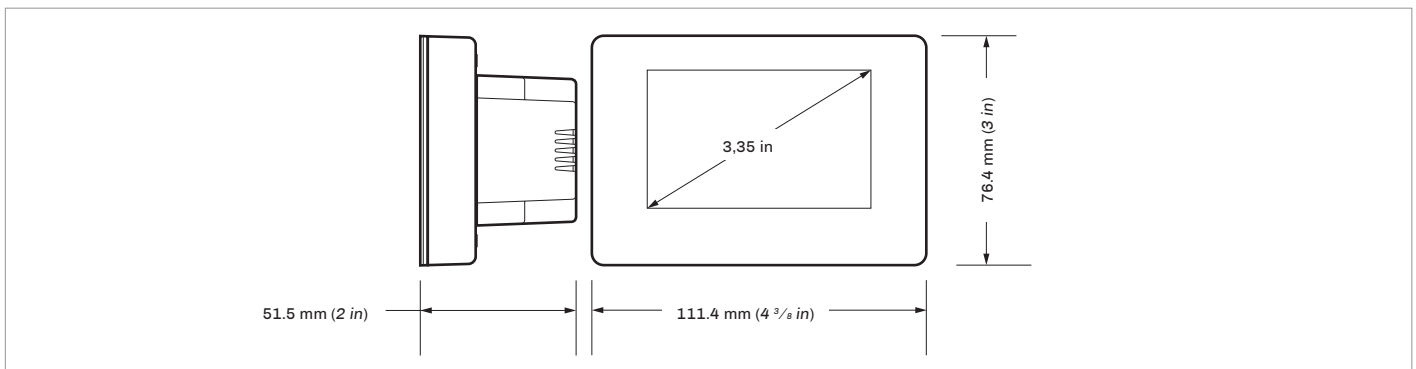

Installation

12 VAC/DC models for panel mounting

To be fitted to a panel with elastic holding flaps

1. Make a hole of 107.6 mm ($3 \frac{15}{16}$ in) x 72.6 mm ($2 \frac{7}{8}$ in) with rounded corners R 3 mm ($\frac{1}{8}$ in)
2. Make the electrical connection without powering up the device
3. Fasten the device to the panel

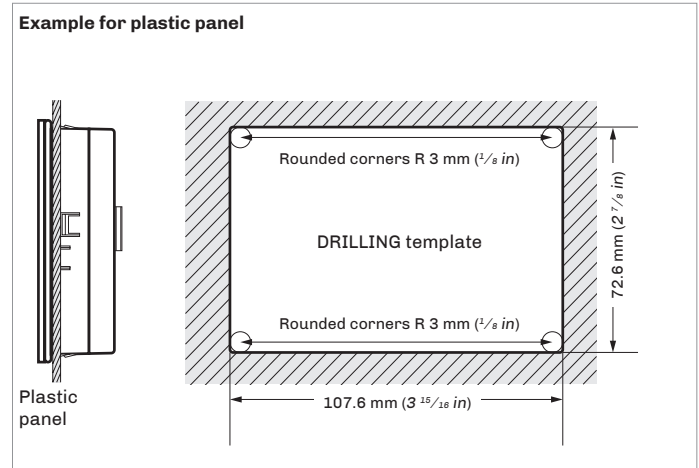

12 VAC/DC models for wall mounting

A) Wall mounting

1. Unhook the back shell from the front through a screwdriver in the proper seat
2. Lean the back shell against the wall in a position suitable to get the connecting cable to pass through the proper opening
3. Use the slots of the back shell as template to drill 4 holes having a diameter suitable to the bolt 5.0 mm ($\frac{3}{16}$ in) diameter bolts are suggested
4. Insert the bolts in the holes drilled in the wall
5. Fasten the back shell at the wall with 4 screws
Countersunk head screws are suggested
6. Make the electrical connection without powering up the device
7. Fasten the front of the device at the back shell

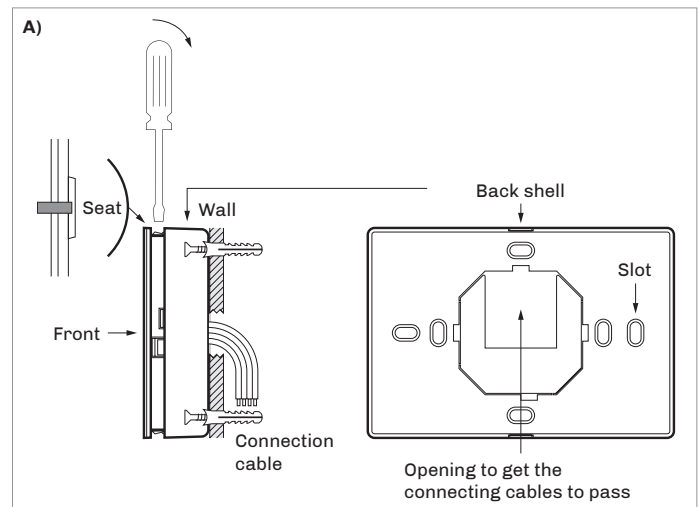

B) Flush mounting box

1. Unhook the back shell from the front through a screwdriver and the proper seat
2. Fasten the back shell at the box with 4 screws
Countersunk head screws are suggested
3. Make the electrical connection without powering up the device
4. Fasten the front of the device at the back shell

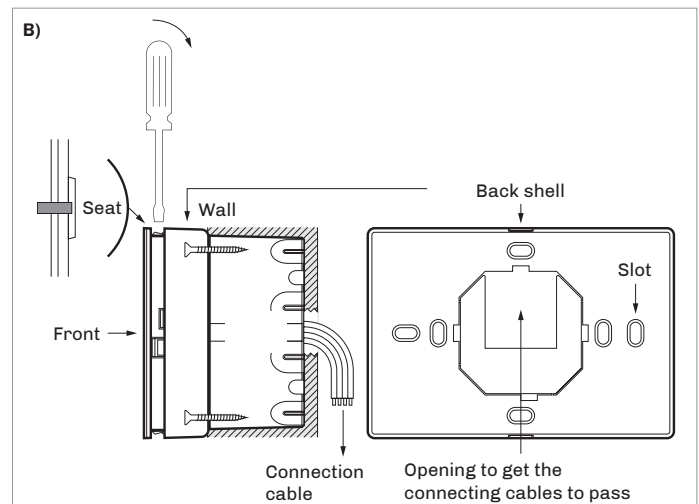

115... 230 VAC models for wall mounting

Mounted onto in-wall electrical box with rear housing of back power module

1. Unhook the back shell from the front through a screwdriver and the proper seat.
2. Fasten the back shell at the box with 4 screws. Countersunk head screws are suggested.
3. Make the electrical connection without powering up the device
4. Fasten the front of the device at the back shell

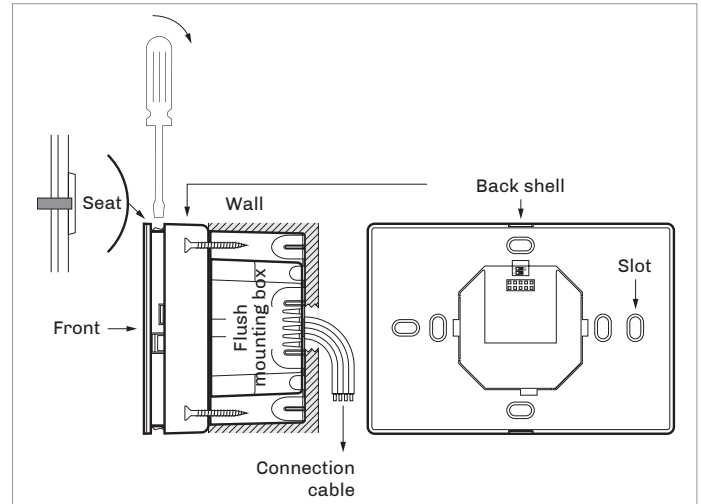

WARNINGS FOR INSTALLATION

- Ensure that the working conditions are within the limits
- Do not install the device close to heat sources, equipment with a strong magnetic field, in places subject to direct sunlight, rain, damp, excessive dust, mechanical vibrations or shocks
- In compliance with safety regulations, the device must be installed properly to ensure adequate protection from contact with electrical parts. All protective parts must be fixed in such a way as to need the aid of a tool to remove them

Electrical connections



WARNINGS FOR ELECTRICAL CONNECTIONS

- Use cables of an adequate section for the current running through them
- To reduce any electromagnetic interference connect the power cables as far away as possible from the signal cables and connect to a CAN and RS-485 MODBUS networks by using a twisted pair

12 VAC/DC models for panel mounting

Connectors and parts

Connector 1

Number	Description
1	INTRABUS port reference (GND)
2	INTRABUS port data (IB)
3	Device power supply (12 VAC/DC); if the device is fed by DC power, connect terminal minus
4	Device power supply (12 VAC/DC); if the device is fed by DC power, connect terminal plus

Connector 2

Number	Description
	EVCO reserved

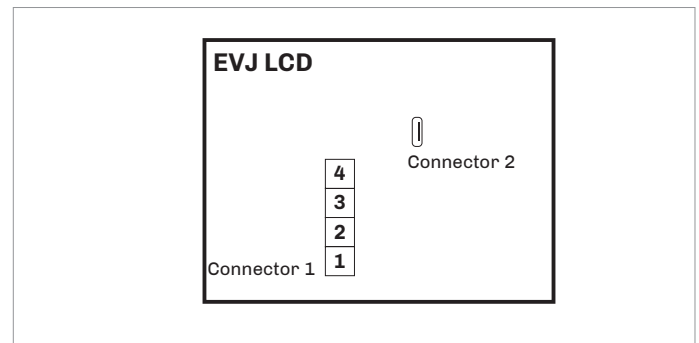

WARNINGS FOR ELECTRICAL CONNECTIONS

- If using an electrical or pneumatic screwdriver, adjust the tightening torque
- If the device has been moved from a cold to a warm place, the humidity may have caused condensation to form inside. Wait about an hour before switching on the power
- Make sure that the supply voltage, electrical frequency and power are within the set limits
- Disconnect the power supply before doing any type of maintenance
- Do not use the device as safety device
- For repairs and for further informations, contact the EVCO sales network; possible returns without label data will not be accepted

Electrical connection with independent power supply



WARNINGS

- Do not supply another device with the same transformer
- The maximum permitted length for connection cables of the INTRABUS port is 30 m (98.4 ft)

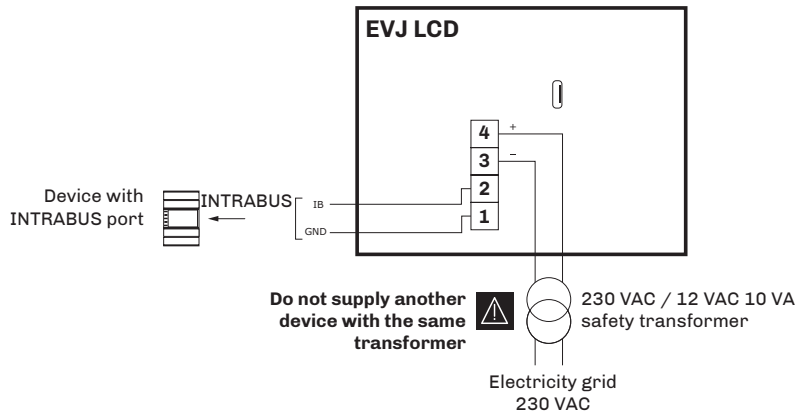

Electrical connection with device powered by a controller

Example: **c-pro 3 OEM**



WARNINGS

- Make sure that the current supplied by the controller is within the limits stated in the TECHNICAL SPECIFICATIONS section
- The maximum permitted length for connection cables of the INTRABUS port is 10 m (32.8 ft)

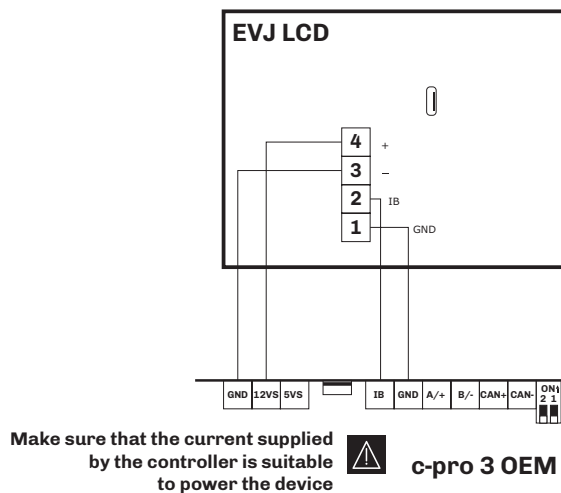

12 VAC/DC models for wall mounting

Connectors and parts

Connector 1

Number	Description
1	INTRABUS port reference (GND) or RS-485 signal B (-) (according to the model)
2	INTRABUS port data (IB) or RS-485 signal A (+) (according to the model)
3	Device power supply (12 VAC/DC). If the device is fed by DC power, connect terminal minus
4	Device power supply (12 VAC/DC). If the device is fed by DC power, connect terminal plus
5	Analog/digital input AI4 (NTC/DI)
6	Reference analog/digital input AI4 (GND)

Connector 2

Number	Description
	EVCO reserved

Micro-switch

Number	Description
2	To terminate the RS-485 MODBUS network
1	EVCO reserved

Temperature (AI3) and humidity (AI5) sensor

Number	Description
	According to the model

Bluetooth Low Energy sensor

Number	Description
	According to the model

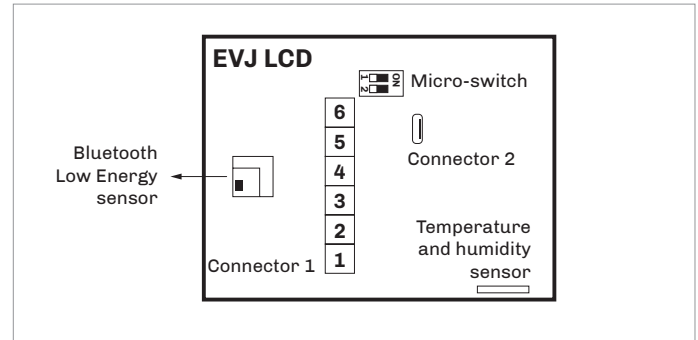

Electrical connection with independent power supply



WARNINGS

- Do not supply another device with the same transformer
- The maximum permitted length for connection cables of the INTRABUS port is 30 m (98.4 ft),
- 1.000 m (3.280 ft) in models with RS-485 with INTRABUS communication protocol

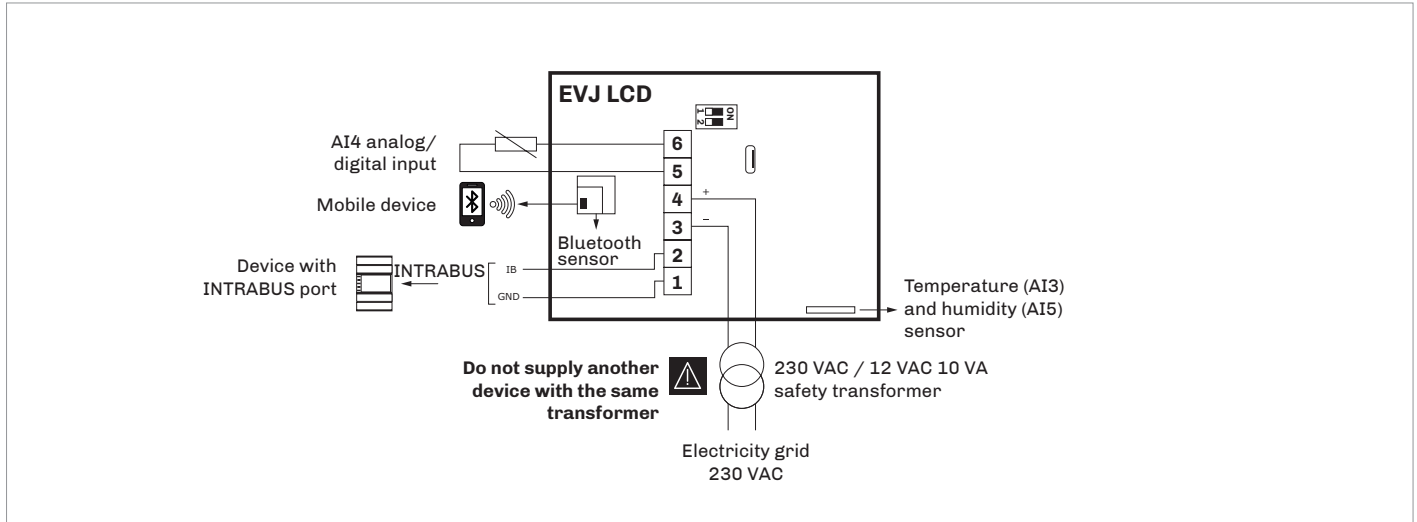

Electrical connection with device powered by a controller

Example: **c-pro 3 OEM**



WARNINGS

- Make sure that the current supplied by the controller is within the limits stated in the TECHNICAL SPECIFICATIONS section
- The maximum permitted length for connection cables of the INTRABUS port is 10 m (32.8 ft)

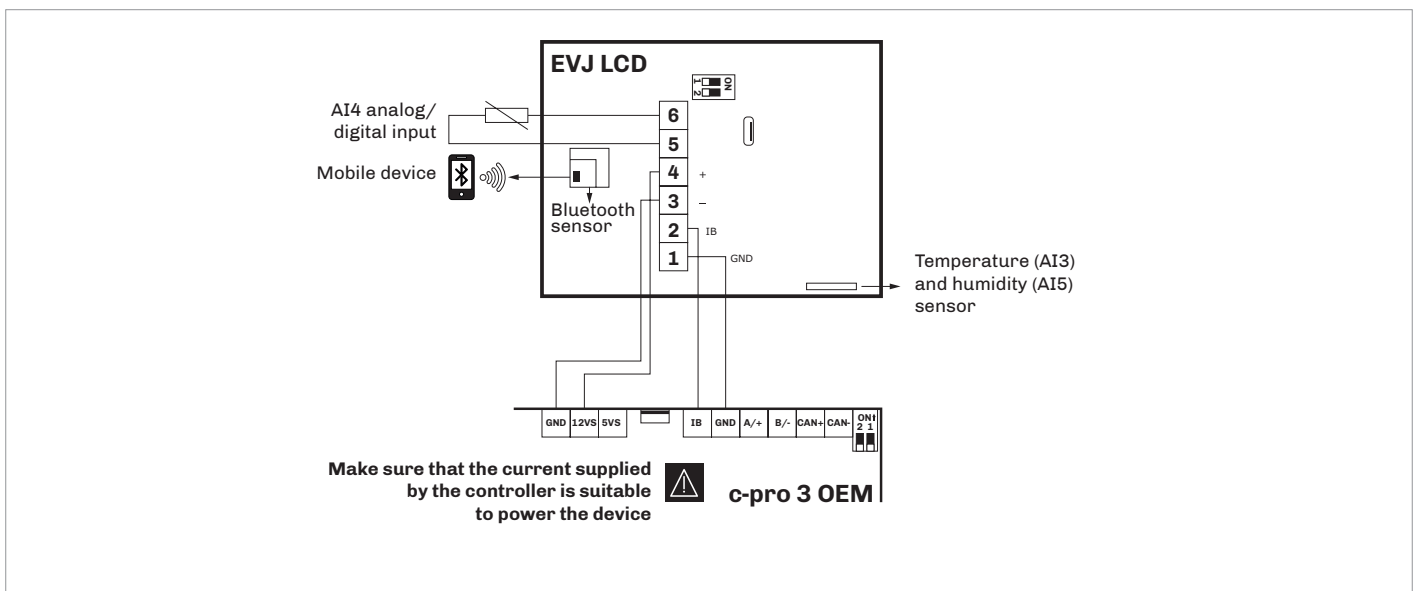

Termination of the RS-485 network

To terminate the RS-485 network:

- Place **micro-switch 2 in position ON**
- Let the **micro-switch 1 in position OFF (EVCO reserved)**

The micro-switch is on the back of the device (remove the back shell from the front before)

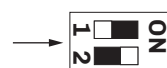

Electrical connection for models with RS-485 port

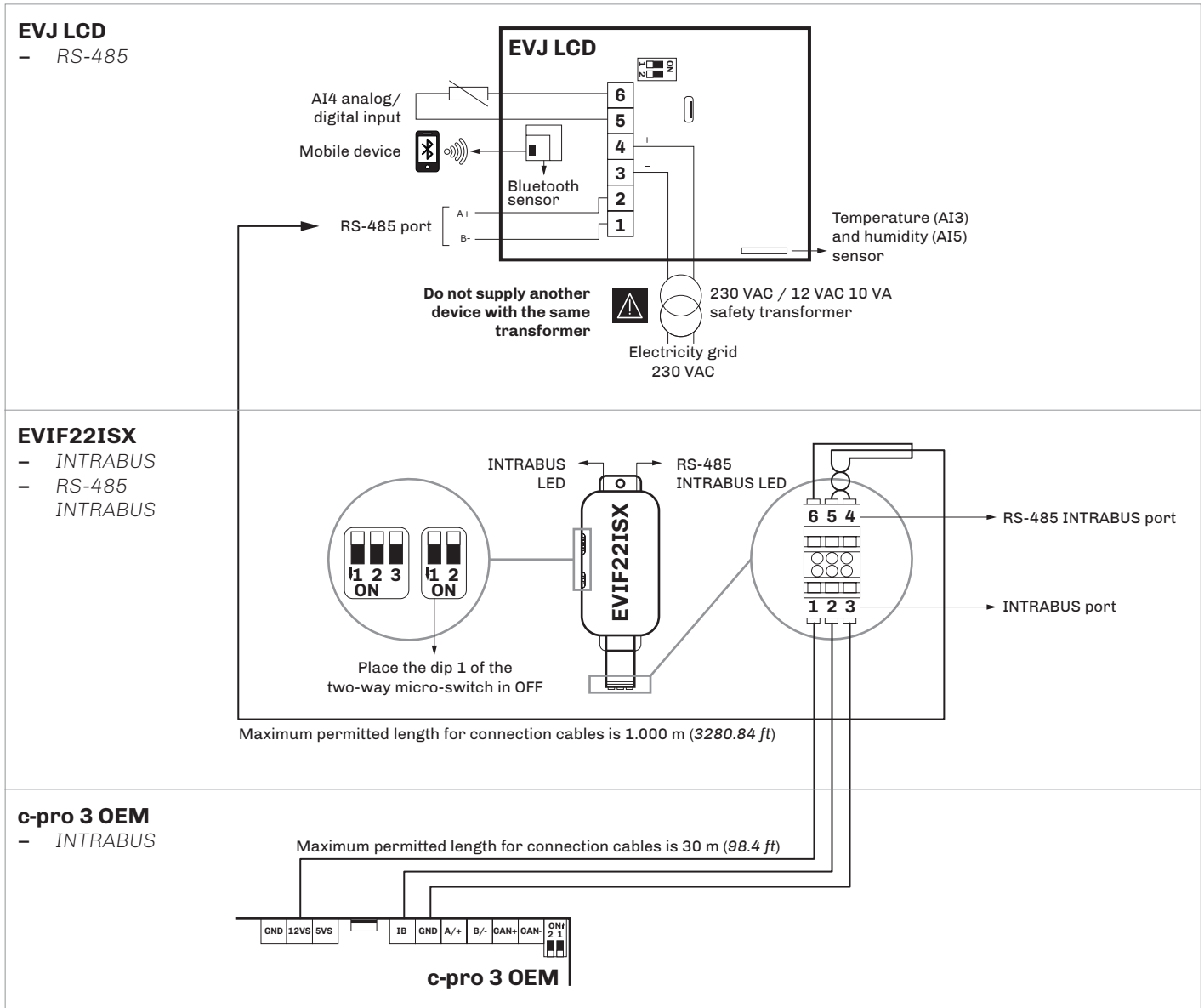

Connectors description

Port	Terminal	Meaning
INTRABUS	1	12 V
	2	INTRABUS port data
	3	INTRABUS port reference (GND)
RS-485	4	RS-485 port reference (GND)
	5	RS-485 port negative signal
	6	RS-485 port positive signal

Micro-switch EVIF22ISX

- Place the **dip 1 of the two-way micro-switch in OFF**



The micro-switch is on the EVIF22ISX device side

115... 230 VAC models for wall mounting

Connectors and parts

Connector 1

Number	Description
1	Device power supply (115... 230 VAC)
2	Device power supply (115... 230 VAC)
3	DO2 digital output normally open contact (1 A res. at 250 VAC)
4	DO1 digital output normally open contact (1 A res. at 250 VAC)
5	DO1 and DO2 digital outputs common contact (max. 2 A)

Connector 2

Number	Description
6	Analog/digital input AI2 (NTC/DI)
7	Analog/digital input AI1 (NTC/DI)
8	Reference analog/digital inputs AI1 and AI2 (GND)
9	INTRABUS port data (IB)
10	INTRABUS port reference (GND)

Temperature (AI3) and humidity (AI5) sensor

Number	Description
	According to the model

Bluetooth Low Energy sensor

Number	Description
	According to the model

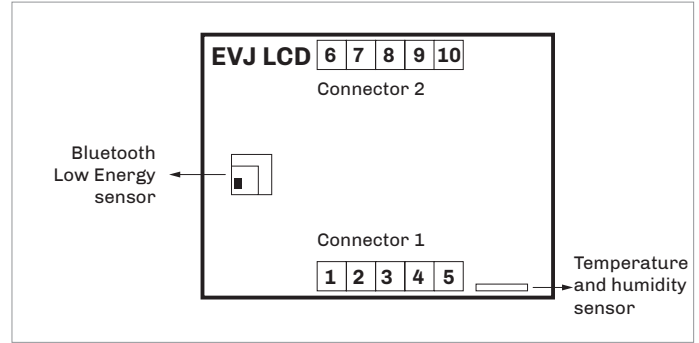

Electrical connection with independent power supply

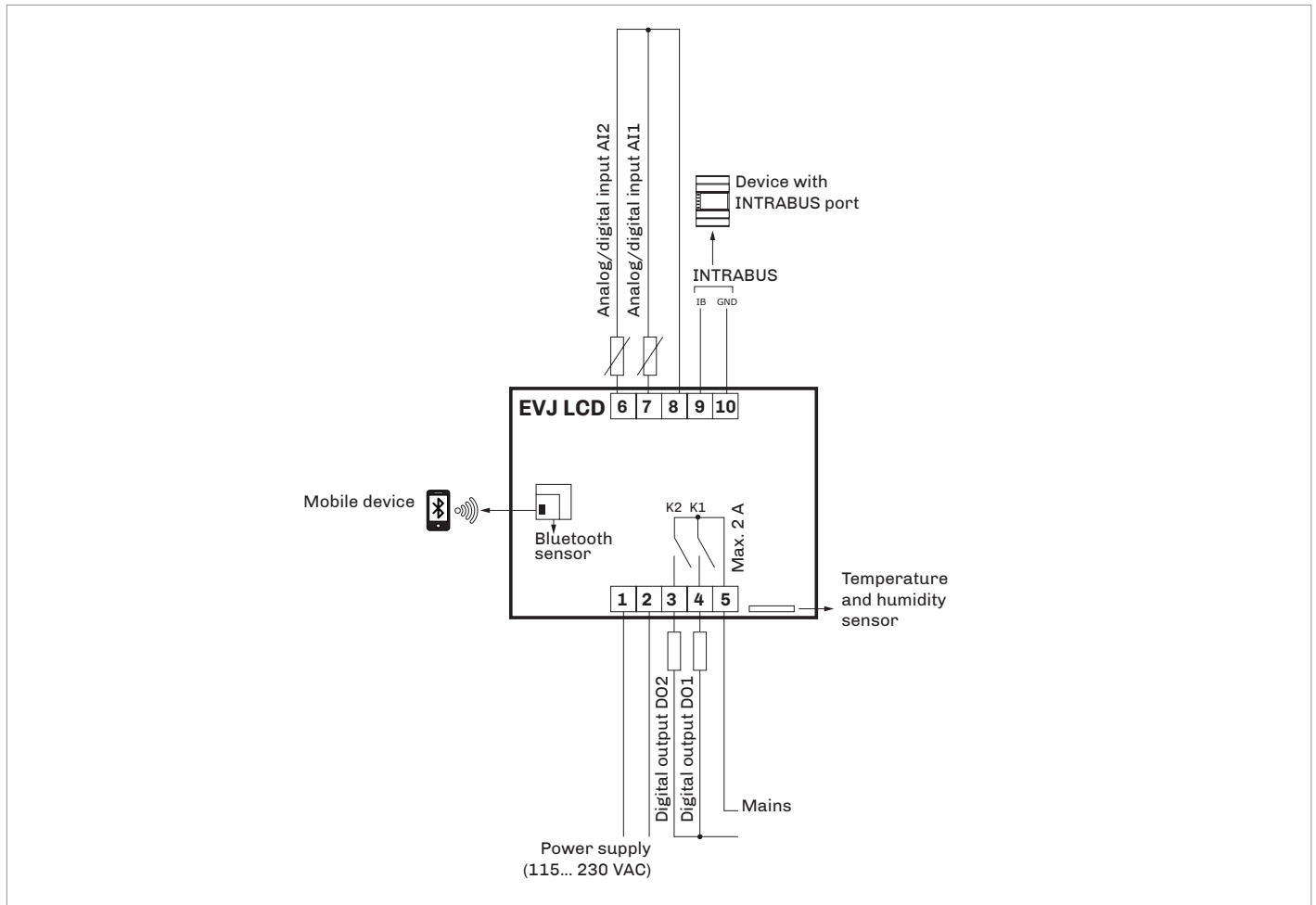

User interface

Key description

Key	Instructions
	ON/STAND-BY
	LEFT AND RIGHT
	UP AND DOWN
SET	SET

Switching ON/OFF the device

Progression	Description
1	Connect the power supply: it will be started an internal test that takes typically a few seconds
2	Touch SET key for 7 seconds: the display will show "Mnu" and "Inf"
3	To switch OFF the device switch OFF the power supply

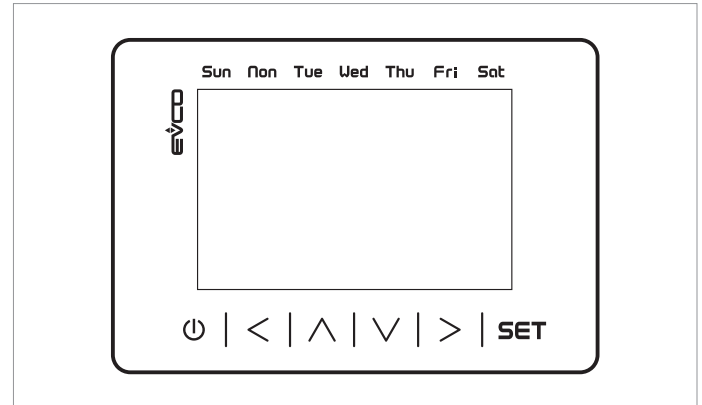

Accessing the procedure

Key	Instructions
SET	Touch SET key for 7 seconds: the display will show "Mnu" and "Inf"
	Touch ON/STAND-BY key few times to return to the previous displays

Accessing the menu

Key	Instructions
SET	Touch SET key for 7 seconds: the display will show "Mnu" and "Inf"
	Touch DOWN key: the display will show "Mnu" and "PAR"
SET	Touch SET key: the display will show "PSU" - Password
SET	Touch SET key: the display will show "0000"
	Touch UP or DOWN keys to set-up the password "-019"
SET	Touch SET key
	Touch UP or DOWN keys to see the menu
SET	Touch SET key to select the menu
	Touch UP or DOWN keys to see the parameters
SET	Touch SET key to access the value
	Touch UP or DOWN keys to set-up the value
SET	Touch SET key to confirm the value
	Touch ON/STAND-BY key few times to return to the previous displays

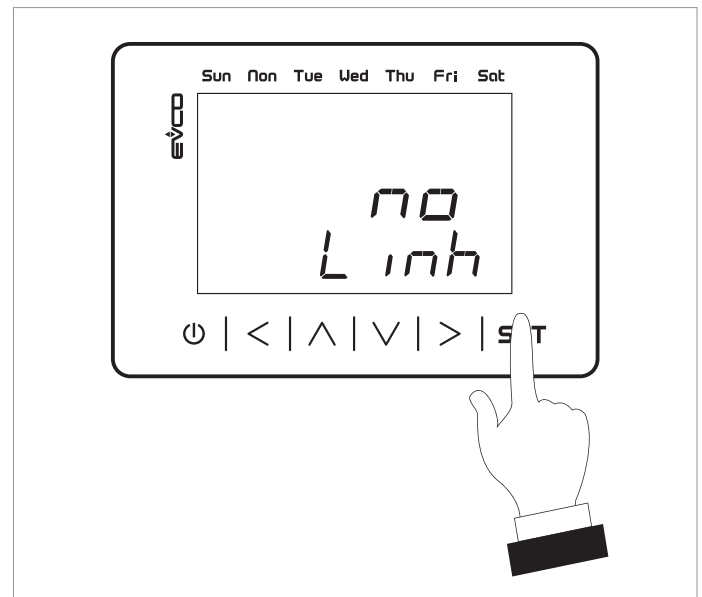

Settings menu

Sensitive areas description and parameters settings





WARNINGS

Turn off the power after changing the configuration

Keys

"InF" menu









Key	Instructions
SET	Touch SET key for 7 seconds: the display will show "Mnu" and "Inf"
SET	Touch SET key to access the parameters
 	Touch UP or DOWN keys to see the parameters
	Touch ON/STAND-BY key few times to return to the previous displays

Parameters settings

"InF" menu

N.	Param.	Def.	"InF" menu	Min/max
1	Prn	-	Project number	-
2	Pru	-	Project version	-
3	Prr	-	Project revision	-
4	FUu	-	Firmware version	-
5	FUr	-	Firmware revision	-
6	FUS	-	Firmware subversion	-
7	HUu	-	Hardware version	-
8	HUr	-	Hardware revision	-

"PAr" menu

Key	Instructions
SET	Touch SET key for 7 seconds: the display will show "Mnu" and "Inf"
	Touch DOWN key: the display will show "Mnu" and "PAr"
SET	Touch SET key: the display will show "PSU" - Password
SET	Touch SET key: the display will show "0000"
 	Touch UP or DOWN keys to set-up the password "-019"
SET	Touch SET key
 	Touch UP or DOWN keys to see the parameters
SET	Touch SET key to access the value
 	Touch UP or DOWN keys to set-up the value
SET	Touch SET key to confirm the value
	Touch ON/STAND-BY key few times to return to the previous displays

"PAr" menu

N.	Param.	Def.	"PAr" menu	Min/max
9	bKU	15	Backlight intensity	0... 100 fixed value 30 in the models with incorporated temperature and humidity sensor
10	bKt	30	Backlight timeout	0... 255 s fixed value 30 in the models with incorporated temperature and humidity sensor
11	bKM	tiME	Backlight mode	off=off on=on (not used in the models with incorporated temperature and humidity sensor) tiME=with bKt
12	EU3	OFF	Enable compatibility with Vled 3	On... OFF

"nEt > Itb" menu

Key	Instructions
SET	Touch SET key for 7 seconds: the display will show "Mnu" and "Inf"
∇	Touch DOWN key twice: the display will show "Mnu" and "nEt"
SET	Touch SET key: the display will show "nEt" and "Itb"
SET	Touch SET key
∧ ∇	Touch UP or DOWN keys to see the parameters
⏻	Touch ON/STAND-BY key few times to return to the previous displays

"nEt > Itb" menu

N.	Param.	Def.	"nEt > Itb" menu	Min/max
13	nOd	4	INTRABUS node	1... 127 se EU3C=On, nOdE=3
14	StA	-	INTRABUS status communication	OK... Err
15	nrH	-	Number of received INTRABUS packages	0... 999
16	ntH	-	Number of transmitted INTRABUS packages	0... 999
17	nEr	-	Number of INTRABUS receipts in error	0... 999
18	bAu	-	INTRABUS baud rate	19200
19	Stb	1	INTRABUS bit stop number	0... 2
20	PtY	2	INTRABUS parity	0... 2

"NET > BLE" menu

Key	Instructions
SET	Touch SET key for 7 seconds: the display will show "Mnu" and "Inf"
∇	Touch DOWN key twice: the display will show "Mnu" and "nEt"
SET	Touch SET key: the display will show "Mnu" and "Itb"
∇	Touch DOWN key: the display will show "Mnu" and "bLE"
SET	Touch SET key
∧ ∇	Touch UP or DOWN keys to see the parameters
SET	Touch SET key to access the value
∧ ∇	Touch UP or DOWN keys to set-up the value (available only for "Pty" parameter)
SET	Touch SET key to confirm the value
⏻	Touch ON/STAND-BY key few times to return to the previous displays

"NET > BLE" menu

N.	Param.	Def.	"NET > BLE" menu	Min/max
21	StA	-	Enable Bluetooth	On... OFF
22	nrH	-	Number of BLE packages received	0... 999
23	ntH	-	Number of BLE transmitted received	0... 999
24	nEr	-	Number of intercepted BLE errors	0... 999
25	bAu	-	BLE baud rate	19200
26	Stb	1	BLE bit stop number	0... 2
27	PtY	2	BLE parity	0... 2

"diA" menu

Key	Instructions
SET	Touch SET key for 7 seconds: the display will show "Mnu" and "Inf"
∇	Touch DOWN key three times: the display will show "Mnu" and "diA"
SET	Touch SET key
∧ ∇	Touch UP or DOWN keys to see the parameters
⏻	Touch ON/STAND-BY key few times to return to the previous displays

"diA" menu

N.	Param.	Def.	"diA" menu	Min/max
28	MEm	-	EEPROM memory status	OK... Err
29	PSU	-	Power supply voltage status	OK... Err

“dEb” menu

Key	Instructions
SET	Touch SET key for 7 seconds: the display will show “Mnu” and “Inf”
∇	Touch DOWN key for times: the display will show “Mnu” and “dEb”
SET	Touch SET key
∧ ∇	Touch UP or DOWN keys to see the parameters
⏻	Touch ON/STAND-BY key few times to return to the previous displays

“dEb > unL” submenu

Key	Instructions
SET	Touch SET key for 7 seconds: the display will show “Mnu” and “Inf”
∇	Touch DOWN key for times: the display will show “Mnu” and “dEb”
SET	Touch SET key
∧ ∇	Touch UP or DOWN keys to see the parameters
∇	Touch DOWN key seven times: the display will show “unL”
SET	Touch SET key
∧ ∇	Touch UP or DOWN keys to see the parameters
SET	Touch SET key to access the value
∧ ∇	Touch UP or DOWN keys to set-up the value
SET	Touch SET key to confirm the value
⏻	Touch ON/STAND-BY key few times to return to the previous displays

“CnF” menu

Key	Instructions
SET	Touch SET key for 7 seconds: the display will show “Mnu” and “Inf”
∇	Touch DOWN key five times: the display will show “Mnu” and “CnF”
SET	Touch SET key
∧ ∇	Touch UP or DOWN keys to see the parameters
⏻	Touch ON/STAND-BY key few times to return to the previous displays

“dEb” menu

N.	Param.	Def.	“dEb” menu	Min/max
30	PSU	-	Power supply voltage value	-
31	P1U	-	AI1 analog input reading	-
32	P2U	-	AI2 analog input reading	-
33	P3U	-	Reserved	-
34	P4U	-	AI4 analog input reading	-
35	tEm	-	Incorporated sensor temperature reading (AI3)	-
36	Hr	-	Incorporated sensor humidity reading (AI5)	-

“dEb > unL” submenu

N.	Param.	Def.	“dEb > unL” submenu	Min/max
37	dO1	-	D01 digital output status	On... OFF
38	dO2	-	D02 digital output status	On... OFF

“CnF” menu

N.	Param.	Def.	“CnF” menu	Min/max
39	bLE	-	Bluetooth availability	On... OFF
40	iPb	-	Incorporated sensor	t rH=temperature and humidity none=no sensor
41	EHT	-	Back-slot for flush mounting box	On... OFF

Technical data

Type	Description	
Purpose of the control device	Function controller	
Construction of the control device	Built-in electronic device	
Container	White and black, self-extinguishing	
Category of heat and fire resistance	D	
Dimensions	12 VAC/DC models for panel mounting	- 111.4 x 76.4 x 25.0 mm - (4 ³ / ₈ x 3 x 1 in)
	12 VAC/DC models for wall mounting	- 111.4 x 76.4 x 18.5 mm (4 ³ / ₈ x 3 x ³ / ₄ in)
	115... 230 VAC models for wall mounting	- 111.4 x 76.4 x 51.5 mm (4 ³ / ₈ x 3 x 2 in)
Mounting methods for the control device	According to the model: - Panel mounting - Wall mounting - In the most common flush mounting box	
Degree of protection provided by the covering	IP30 (IP65 in case of panel mounting)	
Connection method	12 VAC/DC models for panel mounting	Removable screw terminal blocks for wires up to 1 mm ²
	12 VAC/DC or 115... 230 VAC models for wall mounting	Fixed screw terminal blocks for wires up to 1 mm ²
Maximum permitted length for connection cables	Power supply: 10 m (32.8 ft)	
	Analogue/digital input: 10 m (32.8 ft)	
	Digital outputs: 10 m (32.8 ft)	
	INTRABUS port: - 10 m (32.8 ft) if the device is powered by a controller - 30 m (98.4 ft) with independent power supply	
	RS-485 MODBUS port: - 1.000 m (3,280 ft)	
Operating temperature	0 – 40 °C (32 – 104 °F)	
Storage temperature	-20 – 70 °C (-4 – 158 °F)	
Operating humidity	Relative humidity from 5 to 95% non condensing	
Pollution status of the control device	2	
Compliance	- RoHS 2011/65/CE	
	- WEEE 2012/19/EU	
	- REACH (EC) regulation no. 1907/2006	
	- EMC 2014/30/UE	
	- RED 2014/53/UE	
Power supply	12 VAC/DC models for panel and wall mounting	12 VAC (±15%), 50/60 Hz (±3 Hz), max. 2 VA not insulated or 12 VDC (±15%), max. 1 W not insulated (independent power supply or by a controller)
	115... 230 VAC models for wall mounting	115... 230 VAC (+10% -15%) 50/60 Hz (±3 Hz) max. 3 VA insulated
Earthing methods for the control device	None	
Rated impulse-withstand voltage	12 VAC/DC models for panel and wall mounting	330 V
	115... 230 VAC models for wall mounting	2.5 kV

Type	Description	
Over-voltage category	12 VAC/DC models for panel and wall mounting	I
	115... 230 VAC models for wall mounting	II
Software class and structure	A	
Analogue/digital inputs	12 VAC/DC models for panel mounting	None
	12 VAC/DC models for wall mounting	1 for NTC/DI probes
	115... 230 VAC for wall mounting	2 for NTC/DI probes
NTC probes	Measurement field	-40 – 110 °C (from -58 – 230 °F)
	Resolution	0.1 °C (1 °F)
Digital outputs	12 VAC/DC models for panel and wall mounting	None
	115... 230 VAC for wall mounting	2 with electromechanical relay (K1 and K2 relay)
K1 relay	SPST, 1 res. A at 250 VAC	
K2 relay	SPST, 1 res. A at 250 VAC	
Type 1 or Type 2 Actions	Type 1	
Additional features of Type 1 or Type 2 actions	C	
Displays	Two rows and function icons LCD display	
Alarm buzzer	Built-in	
Incorporated sensors	Temperature and humidity (according to the model)	
	Bluetooth Low Energy (according to the model)	
Working range incorporated temperature humidity sensor	0... 40 °C (32... 104 °F)	
Working range incorporated humidity sensor	10... 70% of relative humidity	
Communications ports	1 INTRABUS or RS-485 ports with INTRABUS communication protocol (according to the model)	



EVCO S.p.A.

Via Feltre 81, 32036 Sedico (BL) ITALY

| Tel. +39 0437 8422

| Fax +39 0437 83648

| e-mail info@evco.it

| web www.evco.it

This document and the solutions contained therein are the intellectual property of EVCO and thus protected by the Italian Intellectual Property Rights Code (CPI). EVCO imposes an absolute ban on the full or partial reproduction and disclosure of the content other than with the express approval of EVCO. The customer (manufacturer, installer or end-user) assumes all responsibility for the configuration of the device. EVCO accepts no liability for any possible errors in this document and reserves the right to make any changes, at any time without prejudice to the essential functional and safety features of the equipment.